



PNEUMATICA
CATALOGO PRODOTTI 2025 (REV. 01)

PNEUMATICS
PRODUCT CATALOG 2025 (REV. 01)



SAS
SINTERIZZATI srl



SALA BOLOGNESE (BO) - ITALIA - *ITALY* - SINTERIZZATI - *SINTERED*



SALA BOLOGNESE (BO) - ITALIA - *ITALY* - PNEUMATICA - *PNEUMATIC*

















SAULIEU - FRANCIA - *FRANCE*



CORFÙ - GRECIA - *GREECE*

































SHANGHAI - CINA - *CHINA*

| | | | |
|---|--|---|----|
|  | Le nostre Sedi <i>Our Locations</i> |  | 3 |
|  | Indice generale <i>Index</i> | | 4 |
|  | CONDIZIONI GENERALI DI VENDITA <i>GENERAL SALES CONDITIONS</i> | | 14 |
|  | SAS Sales Network <i>SAS Sales Network</i> | | 15 |
|  | Qualità - I nostri Partner - Certificazioni <i>Quality - Our Partners - Certifications</i> | | 16 |
|  | Fascicoli e cataloghi tecnici <i>Technical Catalogs</i> | | 22 |
|  | Attrezzature personalizzazione prodotti <i>Equipment Customization Products</i> | | 25 |
| | Compatibilità dei materiali rispetto alle sostanze chimiche <i>Compatibility of materials with respect to chemicals</i> | | 26 |
|  | Boccole autolubrificanti <i>Self-lubricating bushes</i> |  | 32 |
|  | SILENZIATORI <i>SILENCERS</i> |  | 33 |
|  | Informazioni tecniche silenziatori <i>Silencers Technical Informations</i> | | 50 |
|  | REGOLATORI <i>REGULATORS</i> |  | 55 |

Sono disponibili le schede tecniche di tutti i prodotti riportati in questo catalogo. Le misure si intendono non impegnative.
Technical catalogs of all our products are available - Dimensions are not binding



























I simboli indicano il luogo di produzione- *Production Places*

| | | | |
|---|---|---|----|
|  | RACCORDI <i>FITTINGS</i> |   | 63 |
|  | Raccordi standard ottone <i>Standard Brass Fittings</i> |  | 64 |
|  | Raccordi rapidi standard ottone <i>Push-in Brass Fittings</i> |  | 74 |
|  | Raccordi rapidi ottone tipo "W" <i>"W" Type Push-in Brass Fittings</i> |  | 78 |
|  | Raccordi rapidi ottone nichelato alta pressione <i>Nickel Plated Brass High Pressure Fittings</i> |  | 80 |
|  | Raccordi acciaio Inox <i>"W" Type Push-in Brass Fittings</i> |   | 81 |
|  | Raccordi microfusi Inox AISI 316 L - AISI 304 <i>AISI 316 L - AISI 304 stainless steel precision cast fittings</i> |  | 85 |
|  | Raccordi standard Inox AISI 316 L <i>AISI 316 L Stainless Steel Standard Fittings</i> |   | 86 |
|  | Raccordi Inox AISI 316 L per uso alimentare <i>AISI 316 L stainless steel fittings for food</i> |   | 87 |
|  | Raccordi rapidi Inox AISI 316 L <i>Quick fittings Inox AISI 316 L</i> |   | 88 |
|  | Raccordi a calzamento AISI 316 L <i>Quick release fittings AISI 316 L</i> |   | 91 |
|  | Raccordi rapidi tecnopolimero <i>Push-in Plastic Fittings</i> |  | 93 |

Sono disponibili le schede tecniche di tutti i prodotti riportati in questo catalogo. Le misure si intendono non impegnative.
Technical catalogs of all our products are available - Dimensions are not binding





























I simboli indicano il luogo di produzione- *Production Places*

| | | | |
|---|--|---|-----|
|  | Compact fittings <i>Compact fittings</i> |  | 97 |
|  | Raccordi portagomma <i>Hose fittings</i> |   | 99 |
|  | Raccordi a compressione in tecnopolimero <i>Compression fittings in polypropylene</i> |  | 105 |
|  | Tubi in alluminio calibrati <i>Calibrated aluminium tubes</i> |  | 112 |
|  | Raccordi a calzamento in tecnopolimero <i>Quick Release Plastic Fittings</i> |  | 113 |
|  | ACCESSORI <i>ACCESSORIES</i> |  | 114 |
|  | Serbatoi <i>Air Tanks</i> |  | 127 |
|  | Ripartitori i alluminio <i>Aluminium Manifolds</i> |  | 128 |
|  | Filtri sinterizzati <i>Sintered Filters</i> |  | 130 |
|  | FILTRI PER COLLA <i>GLUE FILTERS</i> |  | 133 |
|  | TUBI E SPIRALI <i>TUBES</i> |  | 137 |
|  | PAC-P Pistola con protezione <i>TUBES</i> |  | 140 |

Sono disponibili le schede tecniche di tutti i prodotti riportati in questo catalogo. Le misure si intendono non impegnative.
Technical catalogs of all our products are available - Dimensions are not binding

































I simboli indicano il luogo di produzione- *Production Places*

| | | | |
|---|---|---|-----|
|  | PT Pinza tagliatubo <i>TUBES</i> |  | 141 |
|  | Pistole per aria compressa <i>TUBES</i> |  | 142 |
|  | VIBRATORI PNEUMATICI ED ELETTRICI <i>PNEUMATIC AND ELECTRIC VIBRATORS</i> | | 143 |
|  | GIUNTI ROTANTI <i>ROTARY JOINTS</i> |  | 147 |
|  | LAME D'ARIA <i>AIR WINGS - RING BLADES - AIR WIPE SYSTEM</i> |  | 151 |
|  | TUBI REFRIGERATORI PNEUMATICI <i>ICE VALVE / PANEL COOLER</i> |  | 161 |
|  | PNEUMATICA DI CONTROLLO <i>PNEUMATIC CONTROL</i> |    | 167 |
|  | Attuatori pneumatici alluminio <i>Aluminium Pneumatic Actuators</i> |  | 168 |
|  | Attuatori pneumatici tecnopolimero <i>Technopolymer Pneumatic Actuators</i> |  | 168 |
|  | Attuatori pneumatici acciaio Inox AISI 316 <i>AISI 316 L Stainless Steel Pneumatic Actuators</i> |  | 169 |
|  | Attuatori elettrici <i>Electric Actuators</i> |  | 169 |
|  | Sensori fine corsa <i>Limit Switchers</i> |   | 169 |

Sono disponibili le schede tecniche di tutti i prodotti riportati in questo catalogo. Le misure si intendono non impegnative.
Technical catalogs of all our products are available - Dimensions are not binding































I simboli indicano il luogo di produzione- *Production Places*

| | | | |
|---|--|---|-----|
|  | Riduzioni per attuatori <i>Reductions for Actuators</i> |  | 171 |
|  | Filtri sinterizzati bronzo - Inox <i>Sintered bronze - Stainless steel filters</i> |  | 174 |
|  | VALVOLE <i>VALVES</i> |   | 175 |
|  | Valvole serie Industrial in ottone ed Inox <i>Brass / Stainless Steel Industrial Valves</i> |  | 178 |
|  | Valvole per attuatori AISI 316 Sanitary <i>Sanitary Stainless Steel AISI 316 L Valves for Actuators</i> |   | 179 |
|  | Valvole manuali AISI 316 Sanitary <i>Sanitary AISI 316 L Stainless Steel Manual Valves</i> |   | 180 |
|  | Valvole in ottone nichelato a sfera per attuatori <i>Nickel Plated Brass Ball Valves for Actuators</i> |  | 181 |
|  | Valvole in ottone nichelato a sfera manuali <i>Nickel-plated brass ball Manual valves</i> |  | 182 |
|  | Valvole a sfera in UPVC <i>UPVC ball valves</i> |  | 183 |
|  | VALVOLE AUSILIARIE <i>AUXILIARY VALVES</i> |   | 185 |
|  | Pulse Valve <i>Pulse Valve</i> |   | 187 |
|  | Valvole 45° <i>Pneumatic Angle Seat Valves</i> |   | 187 |

Sono disponibili le schede tecniche di tutti i prodotti riportati in questo catalogo. Le misure si intendono non impegnative.
Technical catalogs of all our products are available - Dimensions are not binding































I simboli indicano il luogo di produzione- *Production Places*

| | | | |
|---|--|---|-----|
|  | Valvole 45° F <i>Pneumatic Angle Seat Valves with sensors</i> |   | 187 |
|  | Drain Valve <i>Pneumatic Drain Valve</i> |   | 187 |
|  | Drain Valve temporizzata <i>Drain Valve with timer</i> |  | 187 |
|  | Temporizzatori <i>Timers</i> |  | 188 |
|  | Valvole In-line <i>In-line Solenoid Valves</i> |   | 189 |
|  | Valvole proporzionali <i>Proportional Valves</i> |  | 191 |
|  | Valvole ad alta pressione <i>High Pressure Solenoid Valves</i> |  | 195 |
|  | Valvola di portata a regolazione elettronica <i>Flow Control Electronic Valve</i> |  | 196 |
|  | Pressostati e manometri digitali <i>Digital Pressure Switches & Pressure Gauges</i> |  | 197 |
|  | ELETTROVALVOLE E VALVOLE MANUALI <i>SOLENOID AND MANUAL VALVES</i> |   | 199 |
|  | Elettrovalvole Alluminio <i>Aluminium Solenoid Valves</i> |   | 203 |
|  | Regolatori di flusso per valvole Namur <i>Flow Regulators for Namur Valves</i> |  | 204 |

Sono disponibili le schede tecniche di tutti i prodotti riportati in questo catalogo. Le misure si intendono non impegnative.
Technical catalogs of all our products are available - Dimensions are not binding











I simboli indicano il luogo di produzione- *Production Places*

| | | | | |
|---|---|----------------------|---|-----|
|  | Elettrovalvole ISO <i>ISO Solenoid Valves</i> | <i>Ceramic Spool</i> |  | 206 |
|  | Elettrovalvole Inox <i>Stainless Steel Solenoid Valves</i> | |   | 208 |
|  | Sottobasi tipo Manifold <i>Manifold type sub-bases</i> | |  | 209 |
|  | Elettrovalvole a sicurezza intrinseca <i>Ex-Proof Solenoid Valves</i> | |  | 209 |
|  | Elettrovalvole tipo Tiger <i>Tiger Solenoid Valves</i> | |  | 210 |
|  | Valvole a comando pneumatico - Valvole manuali alluminio <i>Pneumatic and Manual Aluminum Valves</i> | |   | 212 |
|  | Valvole manuali <i>Manual valves</i> | |  | 212 |
|  | Valvole a pedale <i>Foot Valves</i> | |  | 216 |
|  | VALVOLE MULTIPOLARI <i>PLUG-IN TYPE SOLENOID VALVES ISLANDS</i> | |   | 219 |
|  | CILINDRI <i>CYLINDERS</i> | |    | 229 |
|  | Cilindri compatti ISO 21287 <i>ISO 21287 Compact Cylinders</i> | |  | 232 |
|  | Cilindri compatti ISO 21287 anti rotazione <i>Anti Rotation ISO 21287 Compact Cylinders</i> | |  | 232 |

Sono disponibili le schede tecniche di tutti i prodotti riportati in questo catalogo. Le misure si intendono non impegnative.
Technical catalogs of all our products are available - Dimensions are not binding



































I simboli indicano il luogo di produzione- *Production Places*

| | | | |
|---|--|---|-----|
|  | Mini cilindri ISO 6432 Alluminio <i>ISO 6432 Aluminium Mini Cylinders</i> |  | 233 |
|  | Mini cilindri ISO 6432 Inox <i>ISO 6432 Stainless Steel Mini Cylinders</i> |  | 233 |
|  | Cilindri standard alluminio ISO 15552 <i>ISO 15552 Aluminium Standard Cylinders</i> |  | 234 |
|  | Kit per cilindri ISO 15552 Alluminio <i>ISO 15552 Aluminium Standard Cylinders Mounting Kit</i> |  | 234 |
|  | Cilindri Standard ISO 15552 Inox <i>ISO 15552 Stainless Steel Standard Cylinders</i> |   | 235 |
|  | Cilindri con stelo forato <i>Pneumatic Cylinders with perforated rod</i> |  | 236 |
|  | Unità di guida <i>Guiding Units for Cylinders</i> |   | 237 |
|  | Cilindri senza stelo magnetici <i>Magnetic Rodless Cylinders</i> |   | 238 |
|  | Cilindri senza stelo pneumatici <i>Pneumatic Rodless Cylinders</i> |   | 239 |
|  | Cilindri senza stelo pneumatici European Design <i>European design Type Rodless Cylinders</i> | | 240 |
|  | Shock absorbers <i>Shock absorbers</i> |  | 242 |
|  | Attuatori elettrici <i>Electric Actuators</i> | | 247 |

Sono disponibili le schede tecniche di tutti i prodotti riportati in questo catalogo. Le misure si intendono non impegnative.
Technical catalogs of all our products are available - Dimensions are not binding



























I simboli indicano il luogo di produzione- *Production Places*

| | | | |
|---|---|---|-----|
|  | CILINDRI SPECIALI - HANDLING <i>SPECIAL CYLINDERS HANDLING</i> |   | 253 |
|  | Cilindri doppio stelo <i>Pneumatic Twin Rod Cylinders</i> |   | 255 |
|  | Cilindri anti rotazione <i>Pneumatic Anti Rotation Cylinders</i> |   | 255 |
|  | Cilindri stopper <i>Pneumatic Stopper Cylinders</i> |   | 255 |
|  | Pinza parallela <i>Pneumatic Parallel Gripper</i> |   | 256 |
|  | Pinza ad Y 90° <i>Pneumatic 90° Angular Gripper</i> |   | 256 |
|  | Pinza ad Y 180° <i>Pneumatic 180° Angular Gripper</i> |   | 256 |
|  | Pinza Finger <i>Pneumatic Finger Gripper</i> |   | 256 |
|  | Air gripper <i>Pneumatic Air Gripper</i> |   | 257 |
|  | Tavola rotante <i>Pneumatic Rotary Cylinder</i> |   | 257 |
|  | Rotary gripper <i>Pneumatic Rotary gripper</i> |   | 257 |
|  | Cilindro pressore <i>Pneumatic Clamping Cylinder</i> |  | 257 |

Sono disponibili le schede tecniche di tutti i prodotti riportati in questo catalogo. Le misure si intendono non impegnative.
Technical catalogs of all our products are available - Dimensions are not binding



I simboli indicano il luogo di produzione- *Production Places*

| | | | | |
|---|---|---|---|-----|
|  | Sensori magnetici <i>Magnetic Sensors</i> |  | 258 | |
|  | FISSAGGI <i>CYLINDER'S MOUNTING PARTS</i> |  |  | 263 |
|  | Accessori per fissaggi <i>Cylinder Mounting Parts Accessories</i> |  | 269 | |
|  | Protezioni in gomma per teste a snodo <i>Rubber Protections for Rod Ends</i> |  | 270 | |
|  | TRATTAMENTO ARIA <i>AIR TREATMENT UNITS "A" - "D" - "X" TYPE</i> |  | 273 | |
|  | Trattamento aria tipo "A" <i>Air Treatment Unit - "A" Type</i> |  | 276 | |
|  | Trattamento aria tipo "D" <i>Air Treatment Unit - "D" Type</i> |  | 277 | |
|  | Trattamento aria tipo "X" <i>Air Treatment Unit - "X" Type</i> |  | 278 | |
|  | VUOTO <i>VACUUM</i> |  | 283 | |
|  | MOTORI AD ARIA <i>AIR MOTORS</i> |  | 291 | |
|  | Piastre di massa per uso nautico <i>Ground Plates for nautical use</i> |  | 301 | |
|  | EXTRA <i>EXTRA</i> |  | 309 | |

Sono disponibili le schede tecniche di tutti i prodotti riportati in questo catalogo. Le misure si intendono non impegnative.
Technical catalogs of all our products are available - Dimensions are not binding



I simboli indicano il luogo di produzione- *Production Places*

CONDIZIONI GENERALI DI VENDITA - *GENERAL SALES CONDITIONS*

I RESA MERCE: Franco nostro magazzino - **IMBALLO:** 1% - **TRASPORTO:** Sempre a rischio del destinatario anche se la merce è venduta in porto franco. Si prega di voler sempre indicare sugli ordini il nominativo del proprio corriere. In mancanza di tale indicazione decliniamo ogni responsabilità per eventuali disguidi. **MATERIALI RESI:** Non si accetta merce di ritorno senza nostra preventiva autorizzazione ed in ogni caso il reso dovrà avvenire in porto franco. **CONTESTAZIONI:** Non si accettano reclami 8 giorni dopo il ricevimento della merce - **PAGAMENTI:** Le condizioni di pagamento saranno quelle concordate ed indicate in fattura e sono vincolanti. Trascorse le scadenze convenute saranno conteggiati gli interessi di mora calcolati secondo il tasso bancario medio praticato alla data del pagamento - **FORO COMPETENTE:** Bologna - **RISERVA DI PROPRIETÀ:** La merce consegnata rimane di riservato dominio della fornitrice, fino all'avvenuto pagamento - **GARANZIE:** I nostri prodotti sono garantiti da polizza R.C. prodotti.



GB **DELIVERY TERMS:** ExW SAS Sinterizzati's Plant - **PACKING:** 1% - **TRANSPORT:** The risk of transport is carried by the customer, even if it has been agreed that we will take care of, organize or be otherwise involved in the transport. The Customer must always communicate the name of the Carrier. Without such indication we don't accept any liability in case of failures - **RETURNED PRODUCTS:** Subject to SAS's prior written authorization, non-complying products may be returned by Customer at its own expense - **COMPLAINTS:** Any hidden defects of the products must be reported by Customer within 8 days of their receipt - **TERMS OF PAYMENT:** The prices of the products shall be those stated in the corresponding Order Confirmation and Invoice. In case of failure by Customer to pay any amount due, SAS Sinterizzati Srl shall be entitled to calculate interests in arrears as per Legislative Decree - **JURISDICTION COURT:** Bologna - **PRODUCTS PROPERTY:** All goods remain the property of SAS Sinterizzati Srl until payment in full is received - **WARRANTY:** SAS products are guaranteed by insurance R.C.



FR **CONDITIONS DE LIVRAISON:** ExW SAS Sinterizzati - **EMBALLAGE:** 1% du montant de la facture - **TRANSPORT:** Le risque du transport est de la responsabilité du client. Le client doit toujours communiquer le nom du transporteur. Sans ces indications, nous dégageons toute responsabilité dans le cas de problème - **RETOUR DE PRODUITS:** Sans accord écrit de SAS Sinterizzati, tous les coûts concernant le retour de marchandise ne pourront être pris en charge par SAS Sinterizzati - **RÉCLAMATIONS:** Toute non-conformité de produit devra être communiquée sous un délai de 8 jours maximum à réception des marchandises pour que la réclamation puisse être prise en compte - **CONDITIONS DE PAIEMENT:** Les prix et délais de paiement des produits sont ceux qui sont précisés sur nos propositions, confirmation de commande et facturation. Toute facture dont le paiement ne serait pas effectué à la date d'échéance donnera lieu à des calculs d'intérêt suivant décret législatif - **CLAUSE ATTRIBUTIVE DE JURIDICTION:** En cas de différend, le Tribunal de Bologne est seul compétent - **RÉSERVE DE PROPRIÉTÉ:** Le transfert de propriété des marchandises livrées est différé jusqu'au paiement intégral du prix correspondant - **GARANTIE:** Les produits de SAS Sinterizzati sont garantis par une assurance de responsabilité civile.



D **LIEFERBEDINGUNGEN:** ExW SAS Sinterizzati's Werk - **VERPACKUNG:** 1% - **TRANSPORT:** Das Transportrisiko wird vom Kunden getragen, auch wenn es vereinbart wurde, wir kümmern uns um, organisieren oder werden anderweitig am Transport beteiligt. Der Kunde muss immer den Namen des Luftfrachtführers mitteilen. Ohne solche Angabe übernehmen wir keine Haftung bei Ausfällen - **RÜCKGABEPRODUKTE:** Vorbehaltlich der vorherigen schriftlichen Genehmigung von SAS können nicht abweichende Produkte vom Kunden auf eigene Kosten zurückgesandt werden - **BESCHWERDEN:** Alle verborgenen Mängel der Produkte sind zu melden vom Kunden innerhalb von 8 Tagen nach deren Eingang - **ZAHLUNGSBEDINGUNGEN:** Die Preise der Produkte sind diejenigen, die in der entsprechenden Widerrufserklärung angegeben sind. SAS Sinterizzati Srl ist berechtigt, die Verzugszinsen nach dem Gesetzesdekret zu berechnen **GERICHTSSTANDSGERICHT:** Bologna - **PRODUKTE EIGENTUM:** Alle Waren bleiben Eigentum von SAS Sinterizzati Srl bis zur vollständigen Bezahlung erhalten - **WAIRRANTY:** SAS Produkte werden durch Versicherung RC garantiert



E **ENTREGA DE LA MERCANCÍA:** Disponible para el adquirente en nuestro almacén - **EMBALAJE:** 1% - **TRANSPORTE:** Es siempre a riesgo del receptor/adquirente aún cuando la mercancía es vendida en puerto gratuito. Se pide de indicar siempre en los pedidos el nombre de vuestra empresa de transporte/transportista. En ausencia de tal indicación, no aceptamos ninguna responsabilidad por cualquier malentendido o error - **MERCANCÍA DEVUELTA:** No aceptamos devolución de mercancía sin nuestra autorización previa y en cualquier caso la devolución deberá ser hecha a cargo del adquirente. **CONTESTACIONES:** No aceptamos quejas/reclamos 8 días después de la recepción de la mercancía - **PAGOS:** Las condiciones de pago serán las acordadas e indicadas en la factura y son vinculantes. Pasados los plazos acordados, serán aplicados los intereses de demora calculados según el interés bancario promedio aplicado en la fecha de pago - **JURISDICCIÓN:** Bolonia - **RESERVA DE PROPIEDAD:** La mercancía suministrada sigue siendo de nuestra propiedad hasta que el adquirente haya realizado el pago completo de todo - **GARANCIAS:** Nuestros productos están asegurados por la póliza R.C. Productos.



P **ENTREGA:** Em nosso depósito - **EMBALAGEM:** 1% - **TRANSPORTE:** Todos os riscos são responsabilidades do destinatário inclusive quando a entrega for em franco de porte. Indicar sempre o nome do transportador no pedido de compra. Na falta de tal indicação não nos responsabilizamos por qualquer transtorno - **DEVOLUÇÕES:** Não serão aceitas devoluções de mercadorias sem a nossa prévia concordância e em todos os casos tais procedimentos serão custeados pelo emitente - **RECLAMAÇÕES:** Todas as reclamações deverão ser apresentadas em até 8 dias após a entrega da mercadoria - **CONDIÇÕES DE PAGAMENTO:** As condições de pagamento serão previamente acordadas e indicadas no pedido de compra sendo as mesmas indispensáveis. Findo o prazo limite de vencimento estipulado, reservamo-nos o direito de aplicar juros bancários até a regularização do pagamento - **FORO COMPETENTE:** Bolonha **RESERVA DE PROPRIEDADE:** Até a completa finalização dos pagamentos em aberto, reservamo-nos o direito de propriedade da mercadoria fornecida - **GARANTIA:** Nossos produtos são assegurados por uma empresa de responsabilidade civil.



S **ÅTERSTÄLL VAROR:** Ex-verk från vårt lager - **FÖRPACKNING:** 1% - **TRANSPORT:** Alltid på mottagarens risk även om varorna säljs. Vill du alltid ange namnet på din kurir vid beställningar. I avsaknad av denna indikation, avisar vi något ansvar för eventuella fel. **ÅTERBETALAT MATERIAL:** Återlämnade varor accepteras inte utan vårt förhandsgodkännande och i vilket fall som helst måste returen betalas. **Twister:** klagomål accepteras inte 8 dagar efter mottagandet av varorna - **BETALNINGAR:** Betalningsvillkoren är de som avtalats och anges på fakturan och är bindande. När de överenskomna tidsfristerna har gått, beräknas standardräntan beräknas enligt den genomsnittliga bankräntan som tillämpades på betalningsdatumet - **JURISDIKTION:** Bologna - **RESERVE AV ÅGARE:** Levererade varor förblir leverantörens reserverade domän tills betalning har gjorts - **GARANTIER:** I våra produkter garanteras av en RC-policy produkter.



DK **LEVERINGSBETINGELSER:** EXW SAS - **PAKKEOMKOSTNINGER:** 1% - **FORSENDELSE:** Risikoen for transport er pålagt modtageren af varen Selv om afsender er involveret i forsendelsen. Kunden skal altid informere om transportøren som skal bruges, uden denne Acceptere vi ikke klager såfremt noget går galt - **RETURNEREDE VARE:** Omkostninger ved tilbage levering, tilfalder køber - **KLAGER:** ved fejl og mangler skal der informeres skriftligt inden 8 dage fra modtagelse af varen - **BETALINGSBETINGELSER:** Priseme er ifølge fremsendte ordrebeholdninger og fakturaer. Såfremt betaling ikke bliver modtaget i henhold til dette, vil SAS sende faktura på renter og omkostninger med dette - **LOV AFGØRELSE:** Bologna - **EJENDOMSRET AF VARENE:** Indtil fuld betaling er modtaget er ejendomsretten af varene SAS - **GARANTI:** Varene er forsikret under R.C.



RC 交货条款: SAS 工厂交货 - 包装: 1% - 运输: 运输风险由客户承担, 即使运输是我们同意照看或得组织或者以其它方式参与客户必须一直保持与承运人的联系, 否则如果运输失败, 我们不承担任何责任。 - 退回产品: 经SAS事先书面确认的, 不符合规定的产品可由客户自费退回 - 投诉: 产品的任何隐藏缺陷必须在收到后8天内由客户报告 - 付款条款: 产品的货款应为相应订单和发票确认的价格。如客户未能支付任何款项, SAS Sinterizzati Srl有权根据法令计算拖欠的利息。 管辖法院: 博洛尼亚 - 产品财产: 所有货物仍然是SAS Sinterizzati Srl的财产直到收到全额付款 - 保证: SAS产品由保险R.C.



GR Στις εγκαταστάσεις μας. **ΣΥΣΚΕΥΑΣΙΑ:** 1% - **ΜΕΤΑΦΟΡΑ:** Πάντα σε κίνδυνο του παραλήπτη, ακόμη και αν έχει συμφωνηθεί ότι θα τα φροντίσουμε, θα οργανώσουμε ή θα συμμετάσχουμε με άλλο τρόπο στη μεταφορά. Ο Πελάτης πρέπει πάντα να γνωστοποιεί το όνομα του Μεταφορέα. Ελλείψει τέτοιας ένδειξης, παραβλέπουμε οποιαδήποτε ευθύνη για τυχόν σφάλματα. **ΕΠΙΣΤΡΟΦΕΣ ΥΛΙΚΩΝ:** Δεν δεχόμαστε τα εμπορεύματα επιστροφής χωρίς την προηγούμενη εξουσιοδότησή μας και σε κάθε περίπτωση επιστροφή πρέπει να γίνει από τον Πελάτη με δικά του έξοδα. **ΠΑΡΑΠΟΝΑ:** Δεν δεχόμαστε παράπονα 8 ημέρες μετά την παραλαβή των αγαθών. **ΠΛΗΡΩΜΕΣ:** Οι όροι πληρωμής θα είναι εκείνοι που έχουν συμφωνηθεί και αναγράφονται στο τιμολόγιο και είναι δεσμευτικοί. Μετά τις συμφωνημένες προθεσμίες θα υπολογίζονται τόκοι υπερημερίας που υπολογίζονται με βάση το μέσο τραπεζικό επιτόκιο χρέωσης κατά την ημερομηνία της πληρωμής. **ΔΙΚΑΙΟΔΟΣΙΑ:** Δικαστήρια της Μπολόνια. **ΚΡΑΤΗΣΗ ΙΔΙΟΚΤΗΣΙΑΣ:** Όλα τα αγαθά παραμένουν στην ιδιοκτησία του προμηθευτή μέχρι την πλήρη εξόφληση. **ΕΠΥΘΗΣΙΣ:** Ο Τα προϊόντα μας είναι εγγυημένα από την ασφάλεια R.C.



- SALA BOLOGNESE (BO)
- SAULIEU

RETE VENDITA PAESI EXTRA EUROPEI
EXTRA EUROPEAN COUNTRIES SALES NETWORK

| | | | | |
|-----------|-----------|---------|---------------|-----------|
| ARGENTINA | CINA | ISRAELE | NUOVA ZELANDA | TAILANDIA |
| AUSTRALIA | GIAPPONE | MALESIA | PORTOGALLO | TAIWAN |
| CANADA | GIORDANIA | MAROCCO | SINGAPORE | U.S.A. |
| CILE | INDIA | MESSICO | SUD AFRICA | VENEZUELA |

evoluzione
della
specie

evolution
of the
species

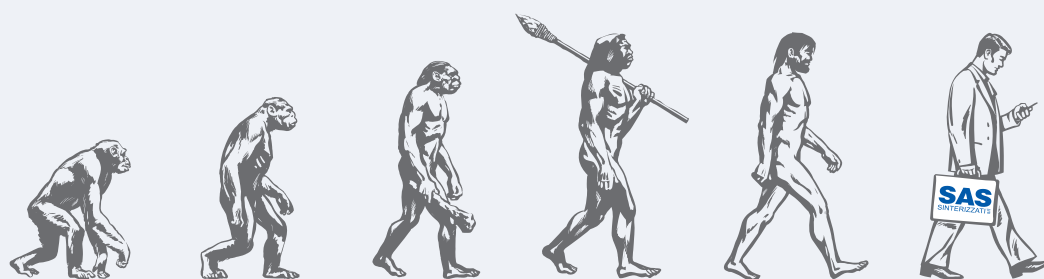
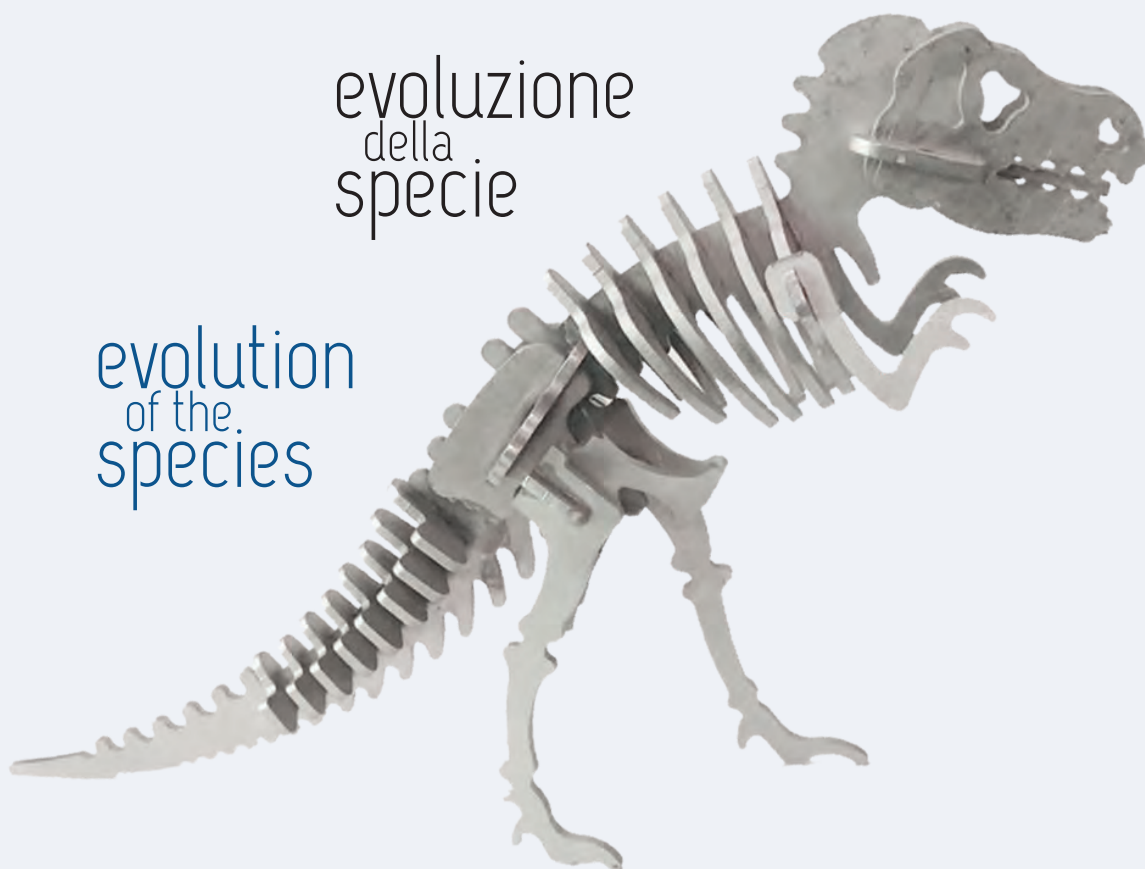



La certificazione viene intesa da Direzione non solo come una motivazione legata al marketing ma soprattutto come obiettivo per migliorare la propria competitività, utilizzando il Sistema Qualità come un efficace strumento per il mantenimento e miglioramento, nel tempo, degli standard qualitativi raggiunti. Tutta la produzione degli stabilimenti SAS è coperta da assicurazione prodotto (danni fisici e materiali).

*The Management sees Certification not only as a marketing motivation but above all as a goal to improve its competitiveness, using the Quality System as an effective reference to maintain and improve the quality standards achieved over time.
All production of the SAS factories is covered by product insurance (physical and material damage).*

LE NOSTRE SEDI
OUR LOCATIONS



Sala Bolognese (BO)
Sinterizzati - *Sintered*
Italia - *Italy*



sasbologna@sassinterizzati.com



Sala Bolognese (BO)
Pneumatica - *Pneumatic*
Italia - *Italy*



sasforli@sassinterizzati.com



Saulieu
Francia - *France*



info@sasfrance-sintering.com



Corfù
Grecia - *Greece*



sasforli@sassinterizzati.com



Shanghai
Cina - *China*



sasbologna@sassinterizzati.com

CERTIFICAZIONI PRODOTTO
PRODUCT CERTIFICATIONS



I NOSTRI PARTNERS
OUR PARTNERS





IO Net, the association of the world's first class certification bodies, is the largest provider of management System Certification in the world. IO Net is composed of more than 30 bodies and counts over 150 subsidiaries all over the globe.

CERTIFICATO N. 23071/11/S
CERTIFICATE No.

SI CERTIFICA CHE IL SISTEMA DI GESTIONE PER LA QUALITÀ DI
 IT IS HEREBY CERTIFIED THAT THE QUALITY MANAGEMENT SYSTEM OF

SAS SINTERIZZATI S.R.L.

VIA MATTEOTTI 1 40010 SALA BOLOGNESE (BO) ITALIA
 NELLE SEGUENTI UNITÀ OPERATIVE / IN THE FOLLOWING OPERATIONAL UNITS

VIA MATTEOTTI 1 40010 SALA BOLOGNESE (BO) ITALIA

È UNITÀ OPERATIVE INDICATE NELLE PAGINE SUCCESSIVE / AND OPERATIONAL UNITS IN THE FOLLOWING PAGES

È CONFORME ALLA NORMA / IS IN COMPLIANCE WITH THE STANDARD

ISO 9001:2015

PER I SEGUENTI CAMPI DI ATTIVITÀ / FOR THE FOLLOWING FIELD(S) OF ACTIVITIES

Per informazioni sulla validità del certificato, visitare il sito www.rina.org

For information concerning validity of the certificate, you can visit the site www.rina.org

Per i requisiti della norma non applicabili al campo di applicazione del sistema di gestione dell'organizzazione, riferirsi alle informazioni documentate relative.

Reference is to be made to the relevant documented information for the requirements of the standard that cannot be applied to the Organization's management system scope

PRODUZIONE DI COMPONENTI SINTERIZZATI. PRODUZIONE, ASSEMBLAGGIO E COMMERCIALIZZAZIONE DI ACCESSORI PER LA PNEUMATICA

IAF:18
 IAF:17
 IAF:29

PRODUCTION OF SINTERED COMPONENTS. PRODUCTION, ASSEMBLY AND TRADE OF PNEUMATIC ACCESSORIES

La validità del presente certificato è subordinata a sorveglianza periodica annuale / semestrale ed al riesame completo del sistema di gestione con periodicità triennale
 The validity of this certificate is dependent on an annual / six monthly audit and on a complete review, every three years, of the management system
 L'uso e la validità del presente certificato sono soggetti al rispetto del documento RINA. Regolamento per la Certificazione di Sistemi di Gestione per la Qualità
 The use and validity of this certificate are subject to compliance with the RINA document / Rules for the certification of Quality Management Systems

| | | | |
|--------------------------------|------------|--|------------|
| Prima emissione First Issue | 06.04.2011 | Data decisione di rinnovo Renewal decision date | 01.10.2020 |
| Data scadenza Expiry Date | 27.09.2024 | Data revisione Revision date | 28.09.2021 |

Rocco Amendola
 Bologna Management System
 Certification, Head

RINA Services S.p.A.
 Via Corsica 12 - 16128 Genova Italy



www.cisq.com

CISQ è la Federazione Italiana di Organismi di Certificazione dei sistemi di gestione aziendale
 CISQ is the Italian Federation of management system Certification Bodies



SGQ N° 002 A

Membro degli Accordi di Muto-Riconoscimento EA, IAF e ILAC
 Signatory of EA, IAF and ILAC Mutual Recognition Agreements



THE INTERNATIONAL CERTIFICATION NETWORK

CERTIFICATE

CISQ /RINA has issued an IQNet recognized certificate that the organization:

SAS SINTERIZZATI S.R.L.

VIA MATTEOTTI 1 40010 SALA BOLOGNESE (BO) ITALIA

in the following operative units:

VIA MATTEOTTI 1 40010 SALA BOLOGNESE (BO) ITALIA

has implemented and maintains a
Quality Management System
for the following scope:

PRODUCTION OF SINTERED COMPONENTS. PRODUCTION, ASSEMBLY AND TRADE OF PNEUMATIC ACCESSORIES

which fulfills the requirements of the following standard:

ISO 9001:2015

Issued on: 2021-09-28

First Issued on: 2011-04-06

Expires on: 2024-09-27

This attestation is directly linked to the IQNet Partner's original certificate and shall not be used as a stand-alone document

CISQ/RINA original certificate no.: **23071/11/S**

Registration Number: IT-74976



Alex Stoichitoiu

Alex Stoichitoiu
 President of IQNET



Mario Romersi

Ing. Mario Romersi
 President of CISQ

IQNet Partners*:

AENOR Spain AFNOR Certification France APCER Portugal CCC Cyprus CISQ Italy
 CQC China CQM China CQS Czech Republic Cro Cert Croatia DQS Holding GmbH Germany EAGLE Certification Group USA
 FCAV Brazil FONDONORMA Venezuela ICONTEC Colombia Inspecta Sertifiointi Oy Finland INTECO Costa Rica
 IRAM Argentina JQA Japan KFQ Korea MIRTEC Greece MSZT Hungary Nemko AS Norway NSAI Ireland
 NYCE-SIGE Mexico PCBC Poland Quality Austria Austria RR Russia SII Israel SIQ Slovenia
 SIRIM QAS International Malaysia SQS Switzerland SRAC Romania TEST St Petersburg Russia TSE Turkey YUQS Serbia

* The list of IQNet partners is valid at the time of issue of this certificate. Updated information is available under www.iqnet-certification.com



Certificat

Certificate

N° 1997/7395.9

Page 1 / 1

AFNOR Certification certifie que le système de management mis en place par :
AFNOR Certification certifies that the management system implemented by:

S.A.S. FRANCE EURL

pour les activités suivantes :
for the following activities:

FABRICATION ET VENTE DE PIECES EN METAL FRITTE.

MANUFACTURING AND SALE OF SINTERED METAL PARTS.

FABBRICAZIONE E VENDITA DI PEZZI SINTERIZZATI.

a été évalué et jugé conforme aux exigences requises par :
has been assessed and found to meet the requirements of:

ISO 9001 : 2015

et est déployé sur les sites suivants :
and is developed on the following locations:

ZONE INDUSTRIELLE FR-21210 SAULIEU

Ce certificat est valable à compter du (année/mois/jour)
This certificate is valid from (year/month/day)

2021-06-08

Jusqu'au
Until

2024-05-26

SignatureFournisseur



Julien NIZRI
Directeur Général d'AFNOR Certification
Managing Director of AFNOR Certification

Flashez ce QR
Code pour vérifier la
validité du certificat

Seul le certificat électronique, consultable sur www.afnor.org, fait foi en temps réel de la certification de l'organisme. The electronic certificate only, available at www.afnor.org, attests in real-time that the company is certified. Accreditation COFRAC n° 4-0301. Certification de Systèmes de Management. Plante disponible sur www.cofrac.fr. COFRAC accreditation n° 4-0301. Management Systems Certification. Scope available on www.cofrac.fr. AFAQ est une marque déposée. AFAQ is a registered trademark. CER11 F 0556.9/07.2020

11 rue Francis de Pressensé - 93571 La Plaine Saint-Denis Cedex - France - T. +33 (0)1 41 62 80 00 - F. +33 (0)1 49 17 90 00
SAS au capital de 18 187 000 € - 479 076 002 RCS Bobigny - www.afnor.org

afnor
CERTIFICATION

CERTIFICATO N. TS/23071/11
CERTIFICATE No.

SI CERTIFICA CHE IL SISTEMA DI GESTIONE PER LA QUALITÀ DI
 IT IS HEREBY CERTIFIED THAT THE QUALITY MANAGEMENT SYSTEM OF

SAS SINTERIZZATI S.R.L.

VIA MATTEOTTI 1 40010 SALA BOLOGNESE (BO) ITALIA

NELLE SEGUENTI UNITÀ OPERATIVE / IN THE FOLLOWING OPERATIONAL UNITS

VIA MATTEOTTI 1 40010 SALA BOLOGNESE (BO) ITALIA

È CONFORME ALLA NORMA E AI REQUISITI DELLO SCHEMA
 IS IN COMPLIANCE WITH THE STANDARD AND THE SCHEME REQUIREMENTS

IATF 16949:2016

PER I SEGUENTI CAMPI DI ATTIVITÀ / FOR THE FOLLOWING FIELD(S) OF ACTIVITIES

PRODUZIONE DI COMPONENTI SINTERIZZATI.

PRODUCTION OF SINTERED PARTS

Essendo stati valutati in accordo alle "Regole per lo schema di certificazione IATF 16949 - 5ª Edizione Novembre 2016"
 Having been assessed in accordance with "IATF 16949 certification scheme rules - 5th Edition November 2016"
 La validità del presente certificato è subordinata a sorveglianza periodica annuale / semestrale ed al riesame completo del sistema di gestione con periodicità triennale
 The validity of this certificate is dependent on an annual/six monthly audit and on a complete review, every three years, of the management system

Andrea Alloisio

Data di emissione
 Issue date 28.09.2021

Data di scadenza
 Expiry date 27.09.2024

Certification Compliance &
 Technical Support, Director

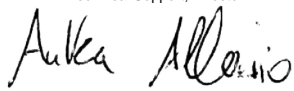

RINA Services S.p.A.
 Via Corsica 12 - 16128 Genova Italy

REQUISITI NON APPLICABILI:
 8.3 - PROGETTAZIONE DEL PRODOTTO
 NOT APPLICABLE REQUIREMENTS:
 8.3 - PRODUCT DESIGN

Consorzio CISQ Automotive Via Velleia 2 - c/o Istituto Italiano dei Plastici Srl 20900 Monza - MB

IL PRESENTE CERTIFICATO È EMESSO IN CONFORMITÀ ALLE REGOLE IATF
 THIS CERTIFICATE IS ISSUED IN CONFORMITY WITH THE IATF RULES

Per informazioni sulla validità del certificato, visitare il sito www.iatfglobaloversight.org
 For information concerning the validity of the certificate, you can visit site www.iatfglobaloversight.org

CISQ AUTOMOTIVE
 Consorzio di Organismi di Certificazione Italiani dei sistemi di gestione aziendale accreditato IATF



CISQ AUTOMOTIVE is a IATF accredited Consortium of Italian Certification Bodies for company management systems



















IAF:18
 IAF:17
 IAF:29

Per informazioni sulla validità del certificato, visitare il sito www.rina.org

For information concerning validity of the certificate, you can visit the site www.rina.org

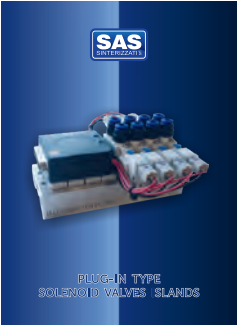

Certificato IATF n. **0427216**
 IATF Certificate n.

| | | | | |
|---|--|--|--|--|
| <p>ATEX</p>  <p>ATTUATORI PNEUMATICI DE - SE REGOLAZIONE 300/45/45</p> <p>ATEX</p> | <p>SILENZIATORI</p>  <p>SILENCERS</p> <p>SILENCERS</p> | <p>REGOLATORI</p>  <p>REGULATORS</p> <p>REGULATORS</p> | <p>RACCORDI</p>  <p>FITTINGS</p> <p>FITTINGS</p> | <p>ACCESSORI</p>  <p>ACCESSORIES</p> <p>ACCESSORIES</p> |
| <p>FILTRI PER COLLA</p>  <p>GLUE FILTERS</p> <p>GLUE FILTERS</p> | <p>TUBI E SPIRALI BASIC</p>  <p>TUBES</p> <p>TUBES BASIC</p> | <p>TUBI E SPIRALI PROFESSIONAL</p>  <p>TUBES - P</p> <p>TUBES PROFESSIONAL</p> | <p>VIBRATORI PNEUMATICI</p>  <p>VIBRATORS</p> <p>PNEUMATIC VIBRATORS</p> | <p>GIUNTI ROTANTI</p>  <p>ROTARY JOINTS</p> <p>ROTARY JOINTS</p> |
| <p>LAME D'ARIA</p>  <p>AIR WINGS</p> <p>MODULAR AIR WINGS®</p> | <p>TUBI REFRIGERATORI PNEUMATICI</p>  <p>ICE VALVE - PANEL COOLER</p> <p>ICE VALVE PANEL COOLER</p> | <p>ATTUATORI PNEUMATICI</p>  <p>ACTUATORS</p> <p>ACTUATORS</p> | <p>VALVOLE A SFERA E FARFALLA</p>  <p>VALVES</p> <p>VALVES</p> | <p>VALVOLE AUSILIARIE</p>  <p>AUXILIARY VALVES</p> <p>AUXILIARY VALVES</p> |
| <p>ELETTOVALVOLE</p>  <p>SOLENOID & MANUAL VALVES</p> <p>SOLENOID VALVES</p> | <p>ELETTOVALVOLE ISO</p>  <p>ISO SOLENOID VALVES</p> <p>ISO SOLENOID VALVES</p> | <p>VALVOLE MULTIPOLARI</p>  <p>PLUG-IN TYPE SOLENOID VALVES ISLANDS</p> <p>PLUG-IN TYPE SOLENOID VALVES ISLANDS</p> | <p>CILINDRI</p>  <p>CYLINDERS</p> <p>CYLINDERS</p> | <p>ATTUATORI ELETTRICI</p>  <p>ELECTRIC ACTUATORS</p> <p>ELECTRIC ACTUATORS</p> |

| | | | | |
|--|---|--|---|---|
|  <p>HANDLING</p> |  <p>FISSAGGI</p> |  <p>TRATTAMENTO ARIA</p> |  <p>VACUUM</p> |  <p>MOTORI AD ARIA</p> |
| <p>HANDLING</p> | <p>CYLINDER'S MOUNTING PARTS</p> | <p>AIR TREATMENT UNIT A-D-X - TYPE</p> | <p>VACUUM</p> | <p>AIR MOTORS</p> |
|  <p>PIASTRE DI MASSA</p> |  <p>EXTRA</p> |  <p>FILTRI</p> |  <p>BOCCOLE SINTERIZZATE</p> |  <p>BOCCOLE KU AUTOLUBRIFICANTI</p> |
| <p>GROUND PLATES</p> | <p>EXTRA</p> | <p>FILTERS</p> | <p>SINTERED BEARINGS</p> | <p>SLIDING BEARINGS</p> |
|  <p>BOCCOLE AUTOLUBRIFICANTI FIPS</p> |  <p>BOCCOLE CON INSERTI IN GRAFITE</p> |  <p>SPINE E RULLINI</p> |  <p>ACCIAIO INOX</p> |  |
| <p>FIPS® SINTERED BEARINGS</p> | <p>BUSHINGS WITH GRAPHITE INSERTS</p> | <p>PINS AND ROLLERS</p> | <p>STAINLESS STEEL</p> | |



Per visualizzare e scaricare i PDF dei Fascicoli Tecnici SAS:
 To view and download the PDFs of the SAS Technical Files:

www.sassinterizzati.com/download



Per tutti i prodotti a catalogo sono disponibili i Fascicoli Tecnici in versione cartacea e/o PDF.
Technical sheets of our products are available in printed or PDF version.



LASER
LASER



STAMPA ETICHETTE
PRINT LABELS



TAMPOGRAFIA
PAD PRINTING



SKIN PACK
SKIN PACK

COMPATIBILITÀ DEI MATERIALI RISPETTO ALLE SOSTANZE CHIMICHE

| | LEGENDA | | | | | | | | | | | | | | |
|---|---------|-----|-------|------|---------------|----------------|-------|------|-----------|--------|--------|------------------|------------------|----------|----------|
| | PTFE | NBR | VITON | EPDM | CR (NEOPRENE) | VMQ (SILICONE) | NORYL | GG25 | ALLUMINIO | OTTONE | BRONZO | BRONZO ALLUMINIO | ACCIAIO CARBONIO | AISI 304 | AISI 316 |
| Acetilene | ● | ● | ● | ● | ● | ● | | ● | ● | ● | ● | ● | ● | ● | ● |
| Acetone | ● | ● | ● | ● | ● | ● | ● | ● | ● | ● | ● | ● | ● | ● | ● |
| Acidi Grassi | ● | ● | ● | ● | ● | ● | ● | ● | ● | ● | ● | ● | ● | ● | ● |
| Acido Acetico | ● | ● | ● | ● | ● | ● | ● | ● | ● | ● | ● | ● | ● | ● | ● |
| Acido Carbonico | ● | ● | ● | ● | ● | ● | ● | ● | ● | ● | ● | ● | ● | ● | ● |
| Acido Citrico | ● | ● | ● | ● | ● | ● | ● | ● | ● | ● | ● | ● | ● | ● | ● |
| Acido Cloridrico (20%) | ● | ● | ● | ● | ● | ● | ● | ● | ● | ● | ● | ● | ● | ● | ● |
| Acido Cloridrico (37% Caldo) | ● | ● | ● | ● | ● | ● | ● | ● | ● | ● | ● | ● | ● | ● | ● |
| Acido Cloridrico (37% Freddo) | ● | ● | ● | ● | ● | ● | ● | ● | ● | ● | ● | ● | ● | ● | ● |
| Acido Fluoridrico (20%) | ● | ● | ● | ● | ● | ● | ● | ● | ● | ● | ● | ● | ● | ● | ● |
| Acido Fluoridrico (75%) | ● | ● | ● | ● | ● | ● | ● | ● | ● | ● | ● | ● | ● | ● | ● |
| Acido Fluoridrico (100% Freddo) | ● | ● | ● | ● | ● | ● | ● | ● | ● | ● | ● | ● | ● | ● | ● |
| Acido Fluoridrico (100% Caldo) | ● | ● | ● | ● | ● | ● | ● | ● | ● | ● | ● | ● | ● | ● | ● |
| Acido Formico | ● | ● | ● | ● | ● | ● | ● | ● | ● | ● | ● | ● | ● | ● | ● |
| Acido Fosforico (40%) | ● | ● | ● | ● | ● | ● | ● | ● | ● | ● | ● | ● | ● | ● | ● |
| Acido Fosforico (40-100%) | ● | ● | ● | ● | ● | ● | ● | ● | ● | ● | ● | ● | ● | ● | ● |
| Acido Fosforico (Crudo) | ● | ● | ● | ● | ● | ● | ● | ● | ● | ● | ● | ● | ● | ● | ● |
| Acido Nitrico (5-10%) | ● | ● | ● | ● | ● | ● | ● | ● | ● | ● | ● | ● | ● | ● | ● |
| Acido Nitrico (20%) | ● | ● | ● | ● | ● | ● | ● | ● | ● | ● | ● | ● | ● | ● | ● |
| Acido Nitrico (50%) | ● | ● | ● | ● | ● | ● | ● | ● | ● | ● | ● | ● | ● | ● | ● |
| Acido Nitrico (Concentrato) | ● | ● | ● | ● | ● | ● | ● | ● | ● | ● | ● | ● | ● | ● | ● |
| Acido Nitroso | ● | ● | ● | ● | ● | ● | ● | ● | ● | ● | ● | ● | ● | ● | ● |
| Acido Solforico (10%) | ● | ● | ● | ● | ● | ● | ● | ● | ● | ● | ● | ● | ● | ● | ● |
| Acido Solforico (10-75%) | ● | ● | ● | ● | ● | ● | ● | ● | ● | ● | ● | ● | ● | ● | ● |
| Acido Solforico (75-100%) | ● | ● | ● | ● | ● | ● | ● | ● | ● | ● | ● | ● | ● | ● | ● |
| Acido Solforoso | ● | ● | ● | ● | ● | ● | ● | ● | ● | ● | ● | ● | ● | ● | ● |
| Acqua Ammoniacale | ● | ● | ● | ● | ● | ● | ● | ● | ● | ● | ● | ● | ● | ● | ● |
| Acqua di Mare | ● | ● | ● | ● | ● | ● | ● | ● | ● | ● | ● | ● | ● | ● | ● |
| Acqua di Piscina | ● | ● | ● | ● | ● | ● | ● | ● | ● | ● | ● | ● | ● | ● | ● |
| Acqua distillata, demineralizzata, de-ionizzata | ● | ● | ● | ● | ● | ● | ● | ● | ● | ● | ● | ● | ● | ● | ● |
| Acqua emulsionata (acqua bianca) | ● | ● | ● | ● | ● | ● | ● | ● | ● | ● | ● | ● | ● | ● | ● |
| Acqua Saponata - Soluzioni di Sapone | ● | ● | ● | ● | ● | ● | ● | ● | ● | ● | ● | ● | ● | ● | ● |
| Acque Acide | ● | ● | ● | ● | ● | ● | ● | ● | ● | ● | ● | ● | ● | ● | ● |
| Acque Bianche (da Cartiera) | ● | ● | ● | ● | ● | ● | ● | ● | ● | ● | ● | ● | ● | ● | ● |
| Alcol Etilico | ● | ● | ● | ● | ● | ● | ● | ● | ● | ● | ● | ● | ● | ● | ● |
| Alcol Metilico | ● | ● | ● | ● | ● | ● | ● | ● | ● | ● | ● | ● | ● | ● | ● |
| Alcol Propilico | ● | ● | ● | ● | ● | ● | ● | ● | ● | ● | ● | ● | ● | ● | ● |
| Ammine | ● | ● | ● | ● | ● | ● | ● | ● | ● | ● | ● | ● | ● | ● | ● |
| Ammoniaca (10%) | ● | ● | ● | ● | ● | ● | ● | ● | ● | ● | ● | ● | ● | ● | ● |
| Ammoniaca, Anidra | ● | ● | ● | ● | ● | ● | ● | ● | ● | ● | ● | ● | ● | ● | ● |
| Anilina | ● | ● | ● | ● | ● | ● | ● | ● | ● | ● | ● | ● | ● | ● | ● |
| Antigelo | ● | ● | ● | ● | ● | ● | ● | ● | ● | ● | ● | ● | ● | ● | ● |

| LEGENDA | | | | | | | | | | | | | | | |
|---|------|-----|-------|------|---------------|----------------|-------|------|-----------|--------|--------|------------------|------------------|----------|----------|
| | PTFE | NBR | VITON | EPDM | CR (NEOPRENE) | VMQ (SILICONE) | NORYL | GG25 | ALLUMINIO | OTTONE | BRONZO | BRONZO ALLUMINIO | ACCIAIO CARBONIO | AISI 304 | AISI 316 |
| Bagni per Placcature: Argentatura | ● | ● | ● | ● | ● | ● | | | | | | | | | ● |
| Bagni per Placcature: Cromatura | ● | ● | ● | ● | ● | ● | | | | | | | | | ● |
| Bagni per Placcature: Nichelatura | ● | ● | ● | | ● | ● | | | | | | | | | ● |
| Benzene | ● | ● | ● | ● | ● | ● | ● | ● | ● | ● | ● | ● | ● | ● | ● |
| Benzina | ● | ● | ● | ● | ● | ● | ● | ● | ● | ● | ● | ● | ● | ● | ● |
| Benzolo, Alcool Benzilico | ● | ● | ● | ● | ● | ● | ● | ● | ● | ● | ● | ● | ● | ● | ● |
| Bicarbonato di Potassio | ● | ● | ● | ● | ● | ● | ● | ● | ● | ● | ● | ● | ● | ● | ● |
| Bicarbonato di Sodio | ● | ● | ● | ● | ● | ● | | ● | ● | ● | ● | ● | ● | ● | ● |
| Biogas | ● | ● | ● | ● | ● | ● | ● | ● | ● | ● | ● | ● | ● | ● | ● |
| Biossido di Carbonio | ● | ● | ● | ● | ● | ● | ● | ● | ● | ● | ● | ● | ● | ● | ● |
| Biossido di Zolfo | ● | ● | ● | ● | ● | ● | ● | | ● | ● | ● | ● | ● | ● | ● |
| Butano | ● | ● | ● | ● | ● | ● | ● | ● | ● | ● | ● | ● | ● | ● | ● |
| Candeggina | ● | ● | ● | ● | ● | ● | | | | | | | | ● | ● |
| Carburante Avio (JP3, JP4, JP5) | ● | ● | ● | ● | ● | ● | ● | ● | ● | ● | ● | ● | ● | ● | ● |
| Cherosene | ● | ● | ● | ● | ● | ● | ● | ● | ● | ● | ● | ● | ● | ● | ● |
| Chetoni | ● | ● | ● | ● | ● | ● | ● | ● | ● | ● | ● | ● | ● | ● | ● |
| Cloro (Liquido Anidro) | ● | ● | ● | ● | ● | ● | | ● | ● | ● | ● | ● | ● | ● | ● |
| Detergenti | ● | ● | ● | ● | ● | ● | | ● | ● | ● | ● | ● | ● | ● | ● |
| Diserbanti | ● | ● | ● | | ● | ● | | | ● | | | | | ● | ● |
| Esano | ● | ● | ● | ● | ● | ● | ● | ● | ● | ● | ● | ● | ● | ● | ● |
| Etano | ● | ● | ● | ● | ● | ● | ● | ● | ● | ● | ● | ● | ● | ● | ● |
| Freon 11 | ● | ● | ● | ● | ● | ● | | ● | ● | ● | ● | ● | ● | ● | ● |
| Freon 113 | ● | ● | ● | ● | ● | ● | | ● | ● | ● | ● | ● | ● | ● | ● |
| Freon 12 (Soluzione Acquosa) | ● | ● | ● | ● | ● | ● | | ● | ● | ● | ● | ● | ● | ● | ● |
| Freon 22 | ● | ● | ● | ● | ● | ● | | ● | ● | ● | ● | ● | ● | ● | ● |
| Freon T.F. | ● | ● | ● | ● | ● | ● | | ● | ● | ● | ● | ● | ● | ● | ● |
| Fluoro | ● | ● | ● | ● | ● | ● | | | ● | ● | ● | ● | ● | ● | ● |
| Formaldeide | ● | ● | ● | ● | ● | ● | ● | ● | ● | ● | ● | ● | ● | ● | ● |
| Gasolio (Diesel) | ● | ● | ● | ● | ● | ● | ● | ● | ● | ● | ● | ● | ● | ● | ● |
| Glicerina | ● | ● | ● | ● | ● | ● | ● | ● | ● | ● | ● | ● | ● | ● | ● |
| Glicole, Glicole Etilenico | ● | ● | ● | ● | ● | ● | ● | ● | ● | ● | ● | ● | ● | ● | ● |
| Glicole Propilenico | ● | ● | ● | ● | ● | ● | ● | ● | ● | ● | ● | ● | ● | ● | ● |
| Idrocarburi Aromatici | ● | ● | ● | ● | ● | ● | ● | ● | ● | ● | ● | ● | ● | ● | ● |
| Idrogeno Gas | ● | ● | ● | ● | ● | ● | | | ● | ● | ● | ● | ● | ● | ● |
| Idrogeno Solforato (Secco) | ● | | ● | ● | ● | ● | | ● | ● | ● | ● | ● | ● | ● | ● |
| Idrogeno Solforato (Soluzione Acquosa) | ● | ● | ● | ● | ● | ● | | ● | ● | ● | ● | ● | ● | ● | ● |
| Idrossido di Potassio | ● | ● | ● | ● | ● | ● | | ● | ● | ● | ● | ● | ● | ● | ● |
| Idrossido di Sodio (Soda Caustica, 20%) | ● | ● | ● | ● | ● | ● | ● | ● | ● | ● | ● | ● | ● | ● | ● |
| Idrossido di Sodio (Soda Caustica, 50%) | ● | ● | ● | ● | ● | ● | ● | ● | ● | ● | ● | ● | ● | ● | ● |
| Idrossido di Sodio (Soda Caustica, 80%) | ● | ● | ● | ● | ● | ● | ● | ● | ● | ● | ● | ● | ● | ● | ● |
| Inchiostro | ● | ● | ● | ● | ● | ● | | ● | | | | | | ● | ● |
| Inibitori della ruggine | ● | ● | ● | | ● | ● | | | | | | | | ● | ● |

COMPATIBILITÀ DEI MATERIALI RISPETTO ALLE SOSTANZE CHIMICHE

| LEGENDA | | | | | | | | | | | | | | | |
|---|------|-----|-------|------|---------------|----------------|-------|------|-----------|--------|--------|------------------|------------------|----------|----------|
| | PTFE | NBR | VITON | EPDM | CR (NEOPRENE) | VMQ (SILICONE) | NORYL | GG25 | ALLUMINIO | OTTONE | BRONZO | BRONZO ALLUMINIO | ACCIAIO CARBONIO | AISI 304 | AISI 316 |
| ● ATTACCO: NESSUNO | | | | | | | | | | | | | | | |
| ● ATTACCO: LEGGERO | | | | | | | | | | | | | | | |
| ● ATTACCO: MODERATO | | | | | | | | | | | | | | | |
| ● ATTACCO: FORTE | | | | | | | | | | | | | | | |
| Ipoclorito di Sodio (20%) | ● | ● | ● | ● | ● | ● | | ● | ● | ● | ● | ● | ● | ● | ● |
| Ipoclorito di Sodio | ● | ● | ● | ● | ● | ● | | ● | ● | ● | ● | ● | ● | ● | ● |
| Lacche, Vernici | ● | ● | ● | ● | ● | ● | | ● | ● | ● | ● | ● | ● | ● | ● |
| Liquidi base Tannino, per Concia | ● | ● | ● | ● | ● | ● | | ● | ● | ● | ● | ● | ● | ● | ● |
| Liquidi Zuccherini | ● | ● | ● | ● | ● | ● | ● | ● | ● | ● | ● | ● | ● | ● | ● |
| Lubrificanti | ● | ● | ● | ● | ● | ● | ● | ● | ● | ● | ● | ● | ● | ● | ● |
| Metano | ● | ● | ● | ● | ● | ● | ● | ● | ● | ● | ● | ● | ● | ● | ● |
| Nafta | ● | ● | ● | ● | ● | ● | ● | ● | ● | ● | ● | ● | ● | ● | ● |
| Naftalene (Naftalina) | ● | ● | ● | ● | ● | ● | ● | ● | ● | ● | ● | ● | ● | ● | ● |
| Oli Combustibili | ● | ● | ● | ● | ● | ● | ● | ● | ● | ● | ● | ● | ● | ● | ● |
| Oli Idraulici (base Petrolio) | ● | ● | ● | ● | ● | ● | ● | ● | ● | ● | ● | ● | ● | ● | ● |
| Oli Idraulici (base Sintetica) | ● | ● | ● | ● | ● | ● | ● | ● | ● | ● | ● | ● | ● | ● | ● |
| Oleum (Acido Solforico Fumante 25%) | ● | ● | ● | ● | ● | ● | ● | ● | ● | ● | ● | ● | ● | ● | ● |
| Olio di Colza | ● | ● | ● | ● | ● | ● | ● | ● | ● | ● | ● | ● | ● | ● | ● |
| Olio da taglio (integrale) | ● | ● | ● | ● | ● | ● | ● | ● | ● | ● | ● | ● | ● | ● | ● |
| Olio da taglio (emulsionato) | ● | ● | ● | ● | ● | ● | ● | ● | ● | ● | ● | ● | ● | ● | ● |
| Olio Diatermico (per trasformatori) | ● | ● | ● | ● | ● | ● | ● | ● | ● | ● | ● | ● | ● | ● | ● |
| Olio Minerale | ● | ● | ● | ● | ● | ● | ● | ● | ● | ● | ● | ● | ● | ● | ● |
| Olio di Oliva | ● | ● | ● | ● | ● | ● | ● | ● | ● | ● | ● | ● | ● | ● | ● |
| Olio di Palma | ● | ● | ● | ● | ● | ● | ● | ● | ● | ● | ● | ● | ● | ● | ● |
| Oli Siliconici | ● | ● | ● | ● | ● | ● | ● | ● | ● | ● | ● | ● | ● | ● | ● |
| Olio per Trasformatori | ● | ● | ● | ● | ● | ● | ● | ● | ● | ● | ● | ● | ● | ● | ● |
| Paraffina | ● | ● | ● | ● | ● | ● | ● | ● | ● | ● | ● | ● | ● | ● | ● |
| Pentano | ● | ● | ● | ● | ● | ● | ● | ● | ● | ● | ● | ● | ● | ● | ● |
| Permanganato di Potassio | ● | ● | ● | ● | ● | ● | ● | ● | ● | ● | ● | ● | ● | ● | ● |
| Perossido di Idrogeno (Acqua Ossigenata, 10%) | ● | ● | ● | ● | ● | ● | ● | ● | ● | ● | ● | ● | ● | ● | ● |
| Perossido di Idrogeno (Acqua Ossigenata, 30%) | ● | ● | ● | ● | ● | ● | ● | ● | ● | ● | ● | ● | ● | ● | ● |
| Perossido di Idrogeno (Acqua Ossigenata, 50%) | ● | ● | ● | ● | ● | ● | ● | ● | ● | ● | ● | ● | ● | ● | ● |
| Perossido di Sodio | ● | ● | ● | ● | ● | ● | ● | ● | ● | ● | ● | ● | ● | ● | ● |
| Petrolio greggio sour (S>1%) | ● | ● | ● | ● | ● | ● | ● | ● | ● | ● | ● | ● | ● | ● | ● |
| Petrolio greggio sweet (S<1%) | ● | ● | ● | ● | ● | ● | ● | ● | ● | ● | ● | ● | ● | ● | ● |
| Potassa | ● | ● | ● | ● | ● | ● | ● | ● | ● | ● | ● | ● | ● | ● | ● |
| Propano - GPL (Liquefatto) | ● | ● | ● | ● | ● | ● | ● | ● | ● | ● | ● | ● | ● | ● | ● |
| Salamoia | ● | ● | ● | ● | ● | ● | ● | ● | ● | ● | ● | ● | ● | ● | ● |
| Soda Caustica (Idrossido di Sodio, 20%) | ● | ● | ● | ● | ● | ● | ● | ● | ● | ● | ● | ● | ● | ● | ● |
| Soda Caustica (Idrossido di Sodio, 50%) | ● | ● | ● | ● | ● | ● | ● | ● | ● | ● | ● | ● | ● | ● | ● |
| Soda Caustica (Idrossido di Sodio, 80%) | ● | ● | ● | ● | ● | ● | ● | ● | ● | ● | ● | ● | ● | ● | ● |
| Solventi per Lacche, Vernici | ● | ● | ● | ● | ● | ● | ● | ● | ● | ● | ● | ● | ● | ● | ● |
| Tinture | ● | ● | ● | ● | ● | ● | ● | ● | ● | ● | ● | ● | ● | ● | ● |
| Trementina | ● | ● | ● | ● | ● | ● | ● | ● | ● | ● | ● | ● | ● | ● | ● |
| Urina, Urea | ● | ● | ● | ● | ● | ● | ● | ● | ● | ● | ● | ● | ● | ● | ● |
| Vernici (Usare Viton per Aromatici) | ● | ● | ● | ● | ● | ● | ● | ● | ● | ● | ● | ● | ● | ● | ● |

| SPECIFICATIONS | PTFE | NBR | VITON | EPDM | CR (NEOPRENE) | VMQ (SILICONE) | NORYL | GG25 | ALUMINUM | BRASS | BRONZE | BRONZE ALUMINUM | CARBON STEEL | AISI 304 | AISI 316 |
|---|------|-----|-------|------|---------------|----------------|-------|------|----------|-------|--------|-----------------|--------------|----------|----------|
| | | | | | | | | | | | | | | | |
| Acetylene | ● | ● | ● | ● | ● | ● | | ● | ● | ● | ● | ● | ● | ● | ● |
| Acetone | ● | ● | ● | ● | ● | ● | ● | ● | ● | ● | ● | ● | ● | ● | ● |
| Fatty acids | ● | ● | ● | ● | ● | ● | ● | ● | ● | ● | ● | ● | ● | ● | ● |
| Acetic acid | ● | ● | ● | ● | ● | ● | ● | ● | ● | ● | ● | ● | ● | ● | ● |
| Carbonic acid | ● | ● | ● | ● | ● | ● | ● | ● | ● | ● | ● | ● | ● | ● | ● |
| Citric acid | ● | ● | ● | ● | ● | ● | ● | ● | ● | ● | ● | ● | ● | ● | ● |
| Hydrochloric acid (20%) | ● | ● | ● | ● | ● | ● | ● | ● | ● | ● | ● | ● | ● | ● | ● |
| Hydrochloric Acid (37% Hot) | ● | ● | ● | ● | ● | ● | ● | ● | ● | ● | ● | ● | ● | ● | ● |
| Hydrochloric Acid (37% Cold) | ● | ● | ● | ● | ● | ● | ● | ● | ● | ● | ● | ● | ● | ● | ● |
| Hydrofluoric acid (20%) | ● | ● | ● | ● | ● | ● | ● | ● | ● | ● | ● | ● | ● | ● | ● |
| Hydrofluoric acid (75%) | ● | ● | ● | ● | ● | ● | ● | ● | ● | ● | ● | ● | ● | ● | ● |
| Hydrofluoric Acid (100% Cold) | ● | ● | ● | ● | ● | ● | ● | ● | ● | ● | ● | ● | ● | ● | ● |
| Hydrofluoric Acid (100% Hot) | ● | ● | ● | ● | ● | ● | ● | ● | ● | ● | ● | ● | ● | ● | ● |
| Formic acid | ● | ● | ● | ● | ● | ● | ● | ● | ● | ● | ● | ● | ● | ● | ● |
| Phosphoric Acid (40%) | ● | ● | ● | ● | ● | ● | ● | ● | ● | ● | ● | ● | ● | ● | ● |
| Phosphoric Acid (40-100%) | ● | ● | ● | ● | ● | ● | ● | ● | ● | ● | ● | ● | ● | ● | ● |
| Phosphoric Acid (Raw) | ● | ● | ● | ● | ● | ● | ● | ● | ● | ● | ● | ● | ● | ● | ● |
| Nitric acid (5-10%) | ● | ● | ● | ● | ● | ● | ● | ● | ● | ● | ● | ● | ● | ● | ● |
| Nitric acid (20%) | ● | ● | ● | ● | ● | ● | ● | ● | ● | ● | ● | ● | ● | ● | ● |
| Nitric acid (50%) | ● | ● | ● | ● | ● | ● | ● | ● | ● | ● | ● | ● | ● | ● | ● |
| Nitric Acid (Concentrated) | ● | ● | ● | ● | ● | ● | ● | ● | ● | ● | ● | ● | ● | ● | ● |
| Nitrous Acid | ● | ● | ● | ● | ● | ● | ● | ● | ● | ● | ● | ● | ● | ● | ● |
| Sulfuric acid (10%) | ● | ● | ● | ● | ● | ● | ● | ● | ● | ● | ● | ● | ● | ● | ● |
| Sulfuric acid (10-75%) | ● | ● | ● | ● | ● | ● | ● | ● | ● | ● | ● | ● | ● | ● | ● |
| Sulfuric acid (75-100%) | ● | ● | ● | ● | ● | ● | ● | ● | ● | ● | ● | ● | ● | ● | ● |
| Sulfuric Acid | ● | ● | ● | ● | ● | ● | ● | ● | ● | ● | ● | ● | ● | ● | ● |
| Ammonia water | ● | ● | ● | ● | ● | ● | ● | ● | ● | ● | ● | ● | ● | ● | ● |
| Sea water | ● | ● | ● | ● | ● | ● | ● | ● | ● | ● | ● | ● | ● | ● | ● |
| Pool water | ● | ● | ● | ● | ● | ● | ● | ● | ● | ● | ● | ● | ● | ● | ● |
| Distilled, demineralized, deionized water | ● | ● | ● | ● | ● | ● | ● | ● | ● | ● | ● | ● | ● | ● | ● |
| Emulsified water (white water) | ● | ● | ● | ● | ● | ● | ● | ● | ● | ● | ● | ● | ● | ● | ● |
| Soapy Water - Soap solutions | ● | ● | ● | ● | ● | ● | ● | ● | ● | ● | ● | ● | ● | ● | ● |
| Acidic Waters | ● | ● | ● | ● | ● | ● | ● | ● | ● | ● | ● | ● | ● | ● | ● |
| White Waters (from cartiera) | ● | ● | ● | ● | ● | ● | ● | ● | ● | ● | ● | ● | ● | ● | ● |
| Ethyl alcohol | ● | ● | ● | ● | ● | ● | ● | ● | ● | ● | ● | ● | ● | ● | ● |
| Methyl alcohol | ● | ● | ● | ● | ● | ● | ● | ● | ● | ● | ● | ● | ● | ● | ● |
| Propyl alcohol | ● | ● | ● | ● | ● | ● | ● | ● | ● | ● | ● | ● | ● | ● | ● |
| Amines | ● | ● | ● | ● | ● | ● | ● | ● | ● | ● | ● | ● | ● | ● | ● |
| Ammonia (10%) | ● | ● | ● | ● | ● | ● | ● | ● | ● | ● | ● | ● | ● | ● | ● |
| Ammonia, Anhydrous | ● | ● | ● | ● | ● | ● | ● | ● | ● | ● | ● | ● | ● | ● | ● |
| Aniline | ● | ● | ● | ● | ● | ● | ● | ● | ● | ● | ● | ● | ● | ● | ● |
| Antifreeze | ● | ● | ● | ● | ● | ● | ● | ● | ● | ● | ● | ● | ● | ● | ● |

COMPATIBILITY OF MATERIALS WITH RESPECT TO CHEMICALS

| SPECIFICATIONS | PTFE | NBR | VITON | EPDM | CR (NEOPRENE) | VMQ (SILICONE) | NORYL | GG25 | ALUMINUM | BRASS | BRONZE | BRONZE ALUMINUM | CARBON STEEL | AISI 304 | AISI 316 |
|--------------------------------------|------|-----|-------|------|---------------|----------------|-------|------|----------|-------|--------|-----------------|--------------|----------|----------|
| | | | | | | | | | | | | | | | |
| Baths for Plating: Silver Plating | ● | ● | ● | ● | ● | ● | | | | | | | | | ● |
| Bagni per Placcatura: Cromatura | ● | ● | ● | ● | ● | ● | | | | | | | | | ● |
| Baths for Plating: Chrome Plating | ● | ● | ● | | ● | ● | | | | | | | | | ● |
| Benzene | ● | ● | ● | ● | ● | ● | ● | ● | ● | ● | ● | ● | ● | ● | ● |
| Gas | ● | ● | ● | ● | ● | ● | ● | ● | ● | ● | ● | ● | ● | ● | ● |
| Benzol, Benzyl alcohol | ● | ● | ● | ● | ● | ● | ● | ● | ● | ● | ● | ● | ● | ● | ● |
| Bicarbonate of Potassium | ● | ● | ● | ● | ● | ● | ● | ● | ● | ● | ● | ● | ● | ● | ● |
| Sodium bicarbonate | ● | ● | ● | ● | ● | ● | ● | ● | ● | ● | ● | ● | ● | ● | ● |
| Biogas | ● | ● | ● | ● | ● | ● | ● | ● | ● | ● | ● | ● | ● | ● | ● |
| Carbon dioxide | ● | ● | ● | ● | ● | ● | ● | ● | ● | ● | ● | ● | ● | ● | ● |
| Sulfur dioxide | ● | ● | ● | ● | ● | ● | ● | ● | ● | ● | ● | ● | ● | ● | ● |
| Butane | ● | ● | ● | ● | ● | ● | ● | ● | ● | ● | ● | ● | ● | ● | ● |
| Bleach | ● | ● | ● | ● | ● | ● | ● | ● | ● | ● | ● | ● | ● | ● | ● |
| Avio fuel (JP3, JP4, JP5) | ● | ● | ● | ● | ● | ● | ● | ● | ● | ● | ● | ● | ● | ● | ● |
| Kerosene | ● | ● | ● | ● | ● | ● | ● | ● | ● | ● | ● | ● | ● | ● | ● |
| Ketones | ● | ● | ● | ● | ● | ● | ● | ● | ● | ● | ● | ● | ● | ● | ● |
| Chlorine (Anhydrous Liquid) | ● | ● | ● | ● | ● | ● | ● | ● | ● | ● | ● | ● | ● | ● | ● |
| Detergents | ● | ● | ● | ● | ● | ● | ● | ● | ● | ● | ● | ● | ● | ● | ● |
| Herbicides | ● | ● | ● | ● | ● | ● | ● | ● | ● | ● | ● | ● | ● | ● | ● |
| Esano | ● | ● | ● | ● | ● | ● | ● | ● | ● | ● | ● | ● | ● | ● | ● |
| Hexane | ● | ● | ● | ● | ● | ● | ● | ● | ● | ● | ● | ● | ● | ● | ● |
| Freon 11 | ● | ● | ● | ● | ● | ● | ● | ● | ● | ● | ● | ● | ● | ● | ● |
| Freon 113 | ● | ● | ● | ● | ● | ● | ● | ● | ● | ● | ● | ● | ● | ● | ● |
| Freon 12 (Aqueous Solution) | ● | ● | ● | ● | ● | ● | ● | ● | ● | ● | ● | ● | ● | ● | ● |
| Freon 22 | ● | ● | ● | ● | ● | ● | ● | ● | ● | ● | ● | ● | ● | ● | ● |
| Freon T.F. | ● | ● | ● | ● | ● | ● | ● | ● | ● | ● | ● | ● | ● | ● | ● |
| Fluorine | ● | ● | ● | ● | ● | ● | ● | ● | ● | ● | ● | ● | ● | ● | ● |
| Formaldehyde | ● | ● | ● | ● | ● | ● | ● | ● | ● | ● | ● | ● | ● | ● | ● |
| Diesel (Diesel) | ● | ● | ● | ● | ● | ● | ● | ● | ● | ● | ● | ● | ● | ● | ● |
| Glycerine | ● | ● | ● | ● | ● | ● | ● | ● | ● | ● | ● | ● | ● | ● | ● |
| Glycol, Ethylene Glycol | ● | ● | ● | ● | ● | ● | ● | ● | ● | ● | ● | ● | ● | ● | ● |
| Propylene glycol | ● | ● | ● | ● | ● | ● | ● | ● | ● | ● | ● | ● | ● | ● | ● |
| Aromatic hydrocarbons | ● | ● | ● | ● | ● | ● | ● | ● | ● | ● | ● | ● | ● | ● | ● |
| Hydrogen Gas | ● | ● | ● | ● | ● | ● | ● | ● | ● | ● | ● | ● | ● | ● | ● |
| Hydrogen Sulphide (Dry) | ● | ● | ● | ● | ● | ● | ● | ● | ● | ● | ● | ● | ● | ● | ● |
| Hydrogen Sulphide (Aqueous Solution) | ● | ● | ● | ● | ● | ● | ● | ● | ● | ● | ● | ● | ● | ● | ● |
| Potassium hydroxide | ● | ● | ● | ● | ● | ● | ● | ● | ● | ● | ● | ● | ● | ● | ● |
| Sodium Hydroxide (Caustic Soda, 20%) | ● | ● | ● | ● | ● | ● | ● | ● | ● | ● | ● | ● | ● | ● | ● |
| Sodium Hydroxide (Caustic Soda, 50%) | ● | ● | ● | ● | ● | ● | ● | ● | ● | ● | ● | ● | ● | ● | ● |
| Sodium Hydroxide (Caustic Soda, 80%) | ● | ● | ● | ● | ● | ● | ● | ● | ● | ● | ● | ● | ● | ● | ● |
| Ink | ● | ● | ● | ● | ● | ● | ● | ● | ● | ● | ● | ● | ● | ● | ● |
| Rust inhibitors | ● | ● | ● | ● | ● | ● | ● | ● | ● | ● | ● | ● | ● | ● | ● |

| SPECIFICATIONS | RECOMMENDED | | | | | | | | | | | | | | | | |
|--|--------------|-------------|------|-----|-------|------|---------------|----------------|-------|------|----------|-------|--------|-----------------|--------------|----------|----------|
| | ● NO EFFECT | EFFECT GOOD | PTFE | NBR | VITON | EPDM | CR (NEOPRENE) | VMQ (SILICONE) | NORYL | GG25 | ALUMINUM | BRASS | BRONZE | BRONZE ALUMINUM | CARBON STEEL | AISI 304 | AISI 316 |
| ● MINOR | FAIR | | | | | | | | | | | | | | | | |
| ● MODERATE EFFECT | NOT SUITABLE | | | | | | | | | | | | | | | | |
| ● SEVERE EFFECT | | | | | | | | | | | | | | | | | |
| Sodium hypochlorite (20%) | ● | ● | ● | ● | ● | ● | ● | ● | ● | ● | ● | ● | ● | ● | ● | ● | ● |
| Sodium hypochlorite | ● | ● | ● | ● | ● | ● | ● | ● | ● | ● | ● | ● | ● | ● | ● | ● | ● |
| Lacquers, Paints | ● | ● | ● | ● | ● | ● | ● | ● | ● | ● | ● | ● | ● | ● | ● | ● | ● |
| Tannin based liquids, for tanning | ● | ● | ● | ● | ● | ● | ● | ● | ● | ● | ● | ● | ● | ● | ● | ● | ● |
| Sugary liquids | ● | ● | ● | ● | ● | ● | ● | ● | ● | ● | ● | ● | ● | ● | ● | ● | ● |
| Lubricants | ● | ● | ● | ● | ● | ● | ● | ● | ● | ● | ● | ● | ● | ● | ● | ● | ● |
| Methane | ● | ● | ● | ● | ● | ● | ● | ● | ● | ● | ● | ● | ● | ● | ● | ● | ● |
| Naphtha | ● | ● | ● | ● | ● | ● | ● | ● | ● | ● | ● | ● | ● | ● | ● | ● | ● |
| Naphthalene (Naphthalene) | ● | ● | ● | ● | ● | ● | ● | ● | ● | ● | ● | ● | ● | ● | ● | ● | ● |
| Fuel Oils | ● | ● | ● | ● | ● | ● | ● | ● | ● | ● | ● | ● | ● | ● | ● | ● | ● |
| Hydraulic oils (Petroleum base) | ● | ● | ● | ● | ● | ● | ● | ● | ● | ● | ● | ● | ● | ● | ● | ● | ● |
| Hydraulic oils (synthetic base) | ● | ● | ● | ● | ● | ● | ● | ● | ● | ● | ● | ● | ● | ● | ● | ● | ● |
| Oleum (Fuming Sulfuric Acid 25%) | ● | ● | ● | ● | ● | ● | ● | ● | ● | ● | ● | ● | ● | ● | ● | ● | ● |
| Rapeseed oil | ● | ● | ● | ● | ● | ● | ● | ● | ● | ● | ● | ● | ● | ● | ● | ● | ● |
| Cutting oil (integral) | ● | ● | ● | ● | ● | ● | ● | ● | ● | ● | ● | ● | ● | ● | ● | ● | ● |
| Cutting oil (emulsified) | ● | ● | ● | ● | ● | ● | ● | ● | ● | ● | ● | ● | ● | ● | ● | ● | ● |
| Thermal oil (for transformers) | ● | ● | ● | ● | ● | ● | ● | ● | ● | ● | ● | ● | ● | ● | ● | ● | ● |
| Mineral oil | ● | ● | ● | ● | ● | ● | ● | ● | ● | ● | ● | ● | ● | ● | ● | ● | ● |
| Olive oil | ● | ● | ● | ● | ● | ● | ● | ● | ● | ● | ● | ● | ● | ● | ● | ● | ● |
| Palm oil | ● | ● | ● | ● | ● | ● | ● | ● | ● | ● | ● | ● | ● | ● | ● | ● | ● |
| Silicone oils | ● | ● | ● | ● | ● | ● | ● | ● | ● | ● | ● | ● | ● | ● | ● | ● | ● |
| Transformer Oil | ● | ● | ● | ● | ● | ● | ● | ● | ● | ● | ● | ● | ● | ● | ● | ● | ● |
| Paraffin | ● | ● | ● | ● | ● | ● | ● | ● | ● | ● | ● | ● | ● | ● | ● | ● | ● |
| Pentane | ● | ● | ● | ● | ● | ● | ● | ● | ● | ● | ● | ● | ● | ● | ● | ● | ● |
| Permcraft of Potassium | ● | ● | ● | ● | ● | ● | ● | ● | ● | ● | ● | ● | ● | ● | ● | ● | ● |
| Hydrogen peroxide (hydrogen peroxide, 10%) | ● | ● | ● | ● | ● | ● | ● | ● | ● | ● | ● | ● | ● | ● | ● | ● | ● |
| Hydrogen peroxide (hydrogen peroxide, 30%) | ● | ● | ● | ● | ● | ● | ● | ● | ● | ● | ● | ● | ● | ● | ● | ● | ● |
| Hydrogen peroxide (hydrogen peroxide, 50%) | ● | ● | ● | ● | ● | ● | ● | ● | ● | ● | ● | ● | ● | ● | ● | ● | ● |
| Sodium peroxide | ● | ● | ● | ● | ● | ● | ● | ● | ● | ● | ● | ● | ● | ● | ● | ● | ● |
| Sour crude oil (S> 1%) | ● | ● | ● | ● | ● | ● | ● | ● | ● | ● | ● | ● | ● | ● | ● | ● | ● |
| Sweet crude oil (S <1%) | ● | ● | ● | ● | ● | ● | ● | ● | ● | ● | ● | ● | ● | ● | ● | ● | ● |
| Potash | ● | ● | ● | ● | ● | ● | ● | ● | ● | ● | ● | ● | ● | ● | ● | ● | ● |
| Propane - LPG (Liquefied) | ● | ● | ● | ● | ● | ● | ● | ● | ● | ● | ● | ● | ● | ● | ● | ● | ● |
| Brine | ● | ● | ● | ● | ● | ● | ● | ● | ● | ● | ● | ● | ● | ● | ● | ● | ● |
| Caustic Soda (Sodium Hydroxide, 20%) | ● | ● | ● | ● | ● | ● | ● | ● | ● | ● | ● | ● | ● | ● | ● | ● | ● |
| Caustic Soda (Sodium Hydroxide, 50%) | ● | ● | ● | ● | ● | ● | ● | ● | ● | ● | ● | ● | ● | ● | ● | ● | ● |
| Caustic Soda (Sodium Hydroxide, 80%) | ● | ● | ● | ● | ● | ● | ● | ● | ● | ● | ● | ● | ● | ● | ● | ● | ● |
| Solvents for Lacquers, Paints | ● | ● | ● | ● | ● | ● | ● | ● | ● | ● | ● | ● | ● | ● | ● | ● | ● |
| Dyes | ● | ● | ● | ● | ● | ● | ● | ● | ● | ● | ● | ● | ● | ● | ● | ● | ● |
| Turpentine | ● | ● | ● | ● | ● | ● | ● | ● | ● | ● | ● | ● | ● | ● | ● | ● | ● |
| Urine, Urea | ● | ● | ● | ● | ● | ● | ● | ● | ● | ● | ● | ● | ● | ● | ● | ● | ● |
| Paints (Use Viton for Aromatics) | ● | ● | ● | ● | ● | ● | ● | ● | ● | ● | ● | ● | ● | ● | ● | ● | ● |

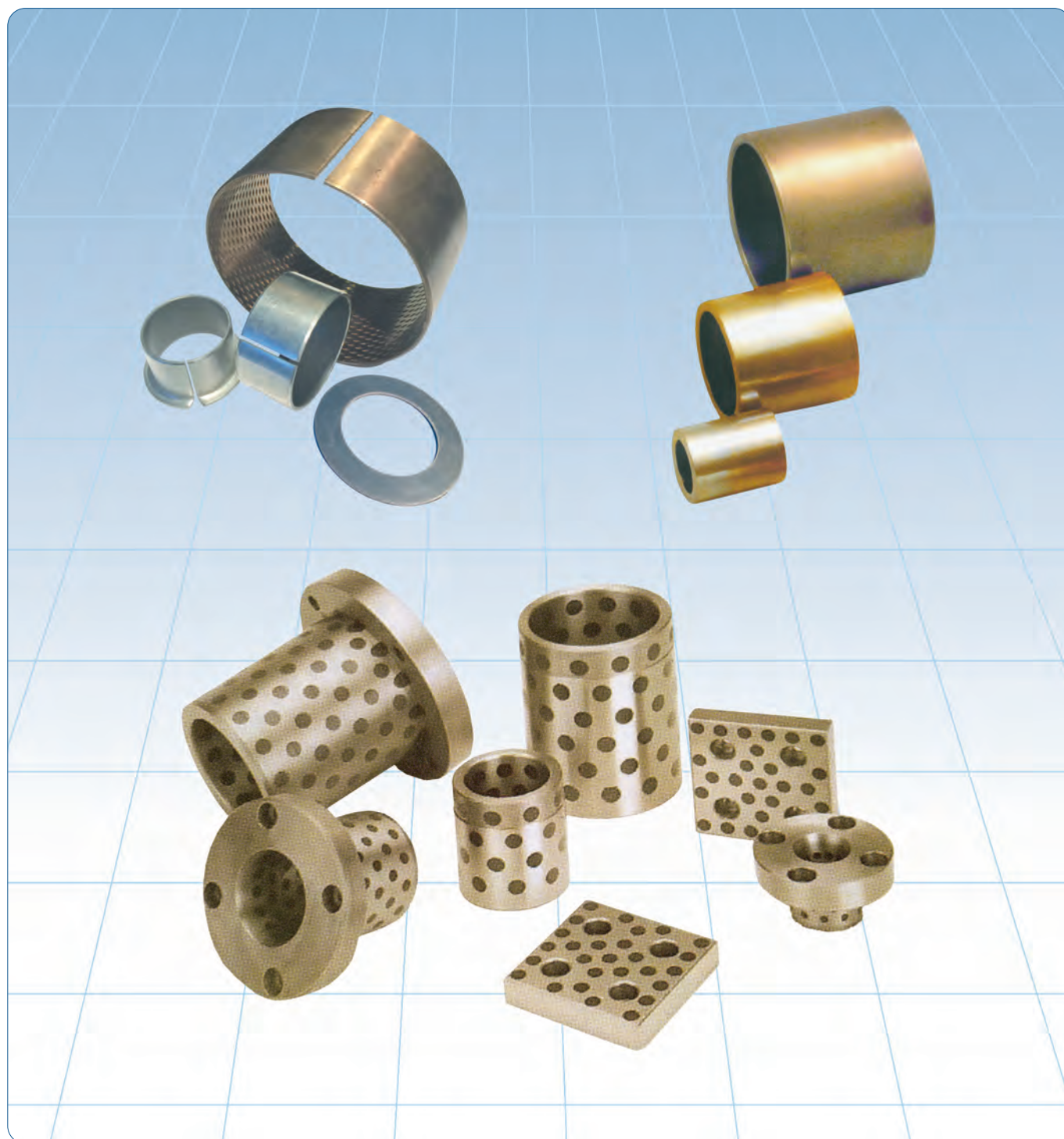

Per maggiori chiarimenti e specifiche consultare il relativo Fascicolo Tecnico.
For further clarifications and specifications, consult the relevant Technical File.



SILENCERS

| | | | | | |
|---|------|----|--|------|----|
|  | SC | 38 |  | SNEC | 38 |
|  | SCT | 38 |  | SNEP | 38 |
|  | SCQ | 38 |  | SNEM | 39 |
|  | SCE | 38 |  | SNE | 39 |
|  | SCFR | 38 |  | SNEA | 39 |
|  | SCB | 38 |  | SCRC | 39 |
|  | SCBT | 38 |  | SCR | 39 |
|  | SBEC | 38 |  | SCRL | 39 |
|  | SBCT | 38 |  | SEFR | 39 |
|  | SEB | 38 |  | SEP | 39 |

| | | | |
|---|----|--|----|
|  SEC | 39 |  SBPT | 40 |
|  SEM | 39 |  SCP | 40 |
|  SE | 40 |  SCL | 40 |
|  SEA | 40 |  SI | 40 |
|  SEJ | 40 |  SS | 41 |
|  SP | 40 |  SL | 41 |
|  ST | 40 |  SFI | 41 |
|  STT | 40 |  SR | 41 |
|  STE | 40 |  SIRP | 41 |
|  SF | 40 |  SIRC | 41 |

| | | | | | |
|---|------|-------|--|--------|----|
|  | SIRM | 41 |  | SPL-F | 42 |
|  | SIR | 41 |  | SPL-P | 42 |
|  | SIRA | 41 |  | SPL-G | 42 |
|  | SPB | 41 |  | SPL-PI | 42 |
|  | SOS | 41-47 |  | SEZ | 42 |
|  | SFEB | 41 |  | SER | 42 |
|  | SEF | 42 |  | SERX | 42 |
|  | SZ | 42 |  | SPX | 42 |
|  | SPL | 42 |  | STF | 42 |

| | | | | | |
|---|---------------|-------|---|---|-------|
|  | SEX | 43 |  | SX-C | 43-48 |
|  | SEX-T | 43 |  | SAE | 44 |
|  | SFEX | 43 |  | SAI | 44 |
|  | SFEP | 43 |  | SAP | 45 |
|  | SEPX | 43 |  | SPL-R | 45 |
|  | SPV VACUUM | 43 |  | SDC | 46 |
|  | ECO-1 | 43 |  | KIT ECO-S | 46 |
|  | ECO-S | 43 |  | SOS | 47 |
|  | ECO-C | 43-48 |  | Informazioni tecniche silenzianti <i>Silencers Technical Informations</i> | 50 |

SILENZIATORI - SILENCERS

SC



| COD | | 🛒 |
|-------|--------|----|
| 1 SC | 1/8" | 25 |
| 2 SC | 1/4" | 25 |
| 3 SC | 3/8" | 10 |
| 4 SC | 1/2" | 10 |
| 5 SC | 3/4" | 5 |
| 6 SC | 1" | 5 |
| 15 SC | M2 | 25 |
| 9 SC | M3 | 25 |
| 7 SC | M5 | 25 |
| 8 SC | 1/8" F | 25 |

Cilindrico
Parallel

SCT



| COD | | 🛒 |
|-------|--------|----|
| 1 SCT | 1/8" | 25 |
| 2 SCT | 1/4" | 25 |
| 3 SCT | 3/8" | 10 |
| 4 SCT | 1/2" | 10 |
| 5 SCT | 3/4" | 5 |
| 6 SCT | 1" | 5 |
| 7 SCT | M5 | 25 |
| 8 SCT | 1/8" F | 25 |

Cilindrico
Parallel

SCQ



| COD | | 🛒 |
|-------|--------|----|
| 1 SCQ | 1/8" | 25 |
| 2 SCQ | 1/4" | 25 |
| 3 SCQ | 3/8" | 10 |
| 4 SCQ | 1/2" | 10 |
| 5 SCQ | 3/4" | 5 |
| 6 SCQ | 1" | 5 |
| 7 SCQ | M5 | 25 |
| 8 SCQ | 1/8" F | 25 |

Cilindrico
Parallel

SCE



| COD | | 🛒 |
|-------|--------|----|
| 1 SCE | 1/8" | 25 |
| 2 SCE | 1/4" | 25 |
| 3 SCE | 3/8" | 10 |
| 4 SCE | 1/2" | 10 |
| 5 SCE | 3/4" | 5 |
| 6 SCE | 1" | 5 |
| 8 SCE | 1/8" F | 25 |

Cilindrico
Parallel

SCFR



| COD | | 🛒 |
|--------|------|----|
| 1 SCFR | 1/8" | 25 |
| 2 SCFR | 1/4" | 25 |
| 3 SCFR | 3/8" | 10 |
| 4 SCFR | 1/2" | 10 |
| 5 SCFR | 3/4" | 5 |
| 6 SCFR | 1" | 5 |

Nipplo in AVP ramato
Copper plated
AVP nipple
Cilindrico
Parallel

SCB



| COD | | 🛒 |
|--------|---------|----|
| 1 SCB | 1/8" | 25 |
| 2 SCB | 1/4" | 25 |
| 3 SCB | 3/8" | 10 |
| 4 SCB | 1/2" | 10 |
| 5 SCB | 3/4" | 5 |
| 6 SCB | 1" | 5 |
| 11 SCB | 1" 1/4 | 1 |
| 12 SCB | 1" 1/2 | 1 |
| 13 SCB | 2" | 1 |
| 24 SCB | 2 "1/2" | 1 |
| 30 SCB | 3" | 1 |
| 40 SCB | 4" | 1 |

SCBT



| COD | | 🛒 |
|--------|------|----|
| 1 SCBT | 1/8" | 25 |
| 2 SCBT | 1/4" | 25 |
| 3 SCBT | 3/8" | 10 |
| 4 SCBT | 1/2" | 10 |
| 5 SCBT | 3/4" | 5 |
| 6 SCBT | 1" | 5 |

SBEC



| COD | | 🛒 |
|--------|------|----|
| 1 SBEC | 1/8" | 25 |
| 2 SBEC | 1/4" | 25 |
| 3 SBEC | 3/8" | 10 |
| 4 SBEC | 1/2" | 10 |

SBCT



| COD | | 🛒 |
|--------|------|----|
| 1 SBCT | 1/8" | 25 |
| 2 SBCT | 1/4" | 25 |
| 3 SBCT | 3/8" | 10 |
| 4 SBCT | 1/2" | 10 |

SEB



| COD | | 🛒 |
|-------|------|----|
| 1 SEB | 1/8" | 25 |
| 2 SEB | 1/4" | 25 |
| 3 SEB | 3/8" | 10 |
| 4 SEB | 1/2" | 10 |
| 5 SEB | 3/4" | 5 |
| 6 SEB | 1" | 5 |

SNEC



| COD | | 🛒 |
|--------|------|----|
| 1 SNEC | 1/8" | 25 |
| 2 SNEC | 1/4" | 25 |
| 3 SNEC | 3/8" | 10 |
| 4 SNEC | 1/2" | 10 |
| 5 SNEC | 3/4" | 5 |
| 6 SNEC | 1" | 5 |

Cilindrico
Parallel

SNEP



| COD | | 🛒 |
|--------|------|----|
| 1 SNEP | 1/8" | 25 |
| 2 SNEP | 1/4" | 25 |
| 3 SNEP | 3/8" | 10 |
| 4 SNEP | 1/2" | 10 |
| 5 SNEP | 3/4" | 5 |
| 6 SNEP | 1" | 5 |

Cilindrico
Parallel

SNEM



| COD | | 🛒 |
|--------|------|----|
| 1 SNEM | 1/8" | 25 |
| 2 SNEM | 1/4" | 25 |
| 3 SNEM | 3/8" | 10 |
| 4 SNEM | 1/2" | 10 |
| 5 SNEM | 3/4" | 5 |
| 6 SNEM | 1" | 5 |

Cilindrico
Parallel

SNE



| COD | | 🛒 |
|-------|------|----|
| 1 SNE | 1/8" | 25 |
| 2 SNE | 1/4" | 25 |
| 3 SNE | 3/8" | 10 |
| 4 SNE | 1/2" | 10 |
| 5 SNE | 3/4" | 5 |
| 6 SNE | 1" | 5 |

Cilindrico
Parallel

SNEA



| COD | | 🛒 |
|--------|------|----|
| 1 SNEA | 1/8" | 25 |
| 2 SNEA | 1/4" | 25 |
| 3 SNEA | 3/8" | 10 |
| 4 SNEA | 1/2" | 10 |
| 5 SNEA | 3/4" | 5 |
| 6 SNEA | 1" | 5 |
| 7 SNEA | M5 | 25 |

Cilindrico
Parallel

SCRC



| COD | | 🛒 |
|--------|------|----|
| 1 SCRC | 1/8" | 25 |
| 2 SCRC | 1/4" | 25 |
| 3 SCRC | 3/8" | 10 |
| 4 SCRC | 1/2" | 10 |
| 5 SCRC | 3/4" | 5 |
| 6 SCRC | 1" | 5 |

Nipplo in nylon
Filtro in ceramica
Nylon nipple
Ceramic filter
Cilindrico
Parallel

SCR



| COD | | 🛒 |
|-------|------|----|
| 1 SCR | 1/8" | 25 |
| 2 SCR | 1/4" | 25 |
| 3 SCR | 3/8" | 10 |
| 4 SCR | 1/2" | 10 |
| 5 SCR | 3/4" | 5 |
| 6 SCR | 1" | 5 |

Nipplo in nylon
Filtro in ceramica
Nylon nipple
Ceramic filter
Cilindrico
Parallel

SCRL



| COD | | 🛒 |
|--------|------|----|
| 1 SCRL | 1/8" | 25 |
| 2 SCRL | 1/4" | 25 |
| 3 SCRL | 3/8" | 10 |
| 4 SCRL | 1/2" | 10 |
| 5 SCRL | 3/4" | 5 |
| 6 SCRL | 1" | 5 |

Nipplo in nylon
Filtro in ceramica
Nylon nipple
Ceramic filter
Cilindrico
Parallel

SEFR



| COD | | 🛒 |
|--------|------|----|
| 1 SEFR | 1/8" | 25 |
| 2 SEFR | 1/4" | 25 |
| 3 SEFR | 3/8" | 10 |
| 4 SEFR | 1/2" | 10 |
| 5 SEFR | 3/4" | 5 |
| 6 SEFR | 1" | 5 |
| 7 SEFR | M5 | 25 |

Nipplo in Avp
ramato
Copper plated
AVP nipple
Cilindrico
Parallel

SEP



| COD | | 🛒 |
|--------|--------|----|
| 1 SEP | 1/8" | 25 |
| 2 SEP | 1/4" | 25 |
| 3 SEP | 3/8" | 10 |
| 4 SEP | 1/2" | 10 |
| 5 SEP | 3/4" | 5 |
| 6 SEP | 1" | 5 |
| 11 SEP | 1" 1/4 | 1 |
| 12 SEP | 1" 1/2 | 1 |
| 13 SEP | 2" | 1 |
| 9 SEP | M3 | 25 |
| 10 SEP | M4 | 25 |
| 7 SEP | M5 | 25 |
| 14 SEP | M6 | 25 |
| 8 SEP | 1/8" F | 25 |

Cilindrico
Parallel

SEC



| COD | | 🛒 |
|--------|--------|----|
| 1 SEC | 1/8" | 25 |
| 2 SEC | 1/4" | 25 |
| 3 SEC | 3/8" | 10 |
| 4 SEC | 1/2" | 10 |
| 5 SEC | 3/4" | 5 |
| 6 SEC | 1" | 5 |
| 11 SEC | 1" 1/4 | 1 |
| 12 SEC | 1" 1/2 | 1 |
| 13 SEC | 2" | 1 |
| 9 SEC | M3 | 25 |
| 10 SEC | M4 | 25 |
| 7 SEC | M5 | 25 |
| 14 SEC | M6 | 25 |
| 8 SEC | 1/8" F | 25 |

Cilindrico
Parallel

SEM



| COD | | 🛒 |
|--------|--------|----|
| 1 SEM | 1/8" | 25 |
| 2 SEM | 1/4" | 25 |
| 3 SEM | 3/8" | 10 |
| 4 SEM | 1/2" | 10 |
| 5 SEM | 3/4" | 5 |
| 6 SEM | 1" | 5 |
| 11 SEM | 1" 1/4 | 1 |
| 12 SEM | 1" 1/2 | 1 |
| 13 SEM | 2" | 1 |
| 9 SEM | M3 | 25 |
| 10 SEM | M4 | 25 |
| 7 SEM | M5 | 25 |
| 14 SEM | M6 | 25 |
| 8 SEM | 1/8" F | 25 |

Cilindrico
Parallel

SILENZIATORI - SILENCERS

SE

Cilindrico
Parallel

| COD | | 🛒 |
|-------|--------|----|
| 1 SE | 1/8" | 25 |
| 2 SE | 1/4" | 25 |
| 3 SE | 3/8" | 10 |
| 4 SE | 1/2" | 10 |
| 5 SE | 3/4" | 5 |
| 6 SE | 1" | 5 |
| 11 SE | 1" 1/4 | 1 |
| 12 SE | 1" 1/2 | 1 |
| 13 SE | 2" | 1 |
| 9 SE | M3 | 25 |
| 10 SE | M4 | 25 |
| 7 SE | M5 | 25 |
| 14 SE | M6 | 25 |
| 8 SE | 1/8" F | 25 |

SEA

Cilindrico
Parallel

| COD | | 🛒 |
|--------|--------|----|
| 1 SEA | 1/8" | 25 |
| 2 SEA | 1/4" | 25 |
| 3 SEA | 3/8" | 10 |
| 4 SEA | 1/2" | 10 |
| 5 SEA | 3/4" | 5 |
| 6 SEA | 1" | 5 |
| 11 SEA | 1" 1/4 | 1 |
| 12 SEA | 1" 1/2 | 1 |
| 13 SEA | 2" | 1 |
| 9 SEA | M3 | 25 |
| 10 SEA | M4 | 25 |
| 7 SEA | M5 | 25 |
| 14 SEA | M6 | 25 |
| 8 SEA | 1/8" F | 25 |

SEJ



Conico - Modello Asco-Joucomatic - Taper - Asco-Joucomatic Type

| COD | | 🛒 |
|-------|------|----|
| 1 SEJ | 1/8" | 25 |
| 2 SEJ | 1/4" | 25 |
| 3 SEJ | 3/8" | 10 |
| 4 SEJ | 1/2" | 10 |
| 5 SEJ | 3/4" | 5 |
| 6 SEJ | 1" | 5 |

SP

Cilindrico
Parallel

| COD | | 🛒 |
|------|------|----|
| 1 SP | 1/8" | 25 |
| 2 SP | 1/4" | 25 |
| 3 SP | 3/8" | 10 |
| 4 SP | 1/2" | 10 |
| 5 SP | 3/4" | 5 |
| 6 SP | 1" | 5 |
| 7 SP | M5 | 25 |

ST

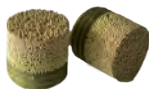
Cilindrico
Parallel

| COD | | 🛒 |
|------|------|----|
| 1 ST | 1/8" | 25 |
| 2 ST | 1/4" | 25 |
| 3 ST | 3/8" | 10 |
| 4 ST | 1/2" | 10 |
| 5 ST | 3/4" | 5 |
| 6 ST | 1" | 5 |

STT

Cilindrico
Parallel

| COD | | 🛒 |
|-------|------|----|
| 1 STT | 1/8" | 25 |
| 2 STT | 1/4" | 25 |
| 3 STT | 3/8" | 10 |
| 4 STT | 1/2" | 10 |
| 5 STT | 3/4" | 5 |
| 6 STT | 1" | 5 |

STE

Cilindrico
Parallel

| COD | | 🛒 |
|-------|------|----|
| 1 STE | 1/8" | 25 |
| 2 STE | 1/4" | 25 |
| 3 STE | 3/8" | 10 |
| 4 STE | 1/2" | 10 |
| 5 STE | 3/4" | 5 |
| 6 STE | 1" | 5 |

SF

Cilindrico
Parallel

| COD | | 🛒 |
|-------|------|----|
| 1 SF | 1/8" | 25 |
| 2 SF | 1/4" | 25 |
| 7 SF | M5 | 25 |
| 14 SF | M6 | 25 |
| 16 SF | M7 | 25 |

SBPT

Cilindrico
Parallel

| COD | | 🛒 |
|--------|------|----|
| 1 SBPT | 1/8" | 25 |
| 2 SBPT | 1/4" | 25 |
| 3 SBPT | 3/8" | 10 |
| 4 SBPT | 1/2" | 10 |

SCP



| COD | | 🛒 |
|-----|------|----|
| SCP | Ø 10 | 25 |

SCL



| COD | | 🛒 |
|-------|------|----|
| 1 SCL | 1/8" | 25 |
| 2 SCL | 1/4" | 25 |
| 3 SCL | 3/8" | 10 |

SI

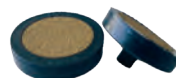
Cilindrico
Parallel

| COD | | 🛒 |
|------|------|----|
| 1 SI | 1/8" | 25 |
| 2 SI | 1/4" | 25 |

Niplo in Nylon - Nylon Nipple

SS



| COD | | 🛒 |
|------|------|----|
| 1 SS | 1/8" | 25 |
| 2 SS | 1/4" | 25 |
| 3 SS | 3/8" | 10 |
| 4 SS | 1/2" | 10 |
| 5 SS | 3/4" | 5 |
| 6 SS | 1" | 5 |
| 7 SS | M5 | 25 |

Cilindrico
Parallel

SL



| COD | | 🛒 |
|-------|--------|----|
| 1 SL | 1/8" | 25 |
| 2 SL | 1/4" | 25 |
| 3 SL | 3/8" | 10 |
| 4 SL | 1/2" | 10 |
| 5 SL | 3/4" | 1 |
| 6 SL | 1" | 1 |
| 11 SL | 1" 1/4 | 1 |
| 12 SL | 1" 1/2 | 1 |
| 13 SL | 2" | 1 |

Cilindrico
Parallel

SFI



| COD | | 🛒 |
|--------|-------|----|
| 35 SFI | Ø 3,5 | 25 |
| 50 SFI | Ø 5,0 | 25 |

SR



| COD | | 🛒 |
|-------|------|----|
| 10 SR | Ø 4 | 25 |
| 20 SR | Ø 5 | 25 |
| 30 SR | Ø 6 | 25 |
| 40 SR | Ø 8 | 25 |
| 50 SR | Ø 10 | 25 |
| 60 SR | Ø 12 | 25 |
| 70 SR | Ø 14 | 25 |

Tubo in Rilsan
Rilsan tube

SIRP



| COD | | 🛒 |
|--------|------|----|
| 1 SIRP | Ø 3 | 25 |
| 2 SIRP | Ø 4 | 25 |
| 3 SIRP | Ø 6 | 25 |
| 4 SIRP | Ø 8 | 25 |
| 5 SIRP | Ø 10 | 25 |
| 6 SIRP | Ø 12 | 25 |

SIRC



| COD | | 🛒 |
|--------|------|----|
| 1 SIRC | Ø 3 | 25 |
| 2 SIRC | Ø 4 | 25 |
| 3 SIRC | Ø 6 | 25 |
| 4 SIRC | Ø 8 | 25 |
| 5 SIRC | Ø 10 | 25 |
| 6 SIRC | Ø 12 | 25 |

SIRM



| COD | | 🛒 |
|--------|------|----|
| 1 SIRM | Ø 3 | 25 |
| 2 SIRM | Ø 4 | 25 |
| 3 SIRM | Ø 6 | 25 |
| 4 SIRM | Ø 8 | 25 |
| 5 SIRM | Ø 10 | 25 |
| 6 SIRM | Ø 12 | 25 |

SIR



| COD | | 🛒 |
|-------|------|----|
| 1 SIR | Ø 3 | 25 |
| 2 SIR | Ø 4 | 25 |
| 3 SIR | Ø 6 | 25 |
| 4 SIR | Ø 8 | 25 |
| 5 SIR | Ø 10 | 25 |
| 6 SIR | Ø 12 | 25 |

SIRA



| COD | | 🛒 |
|--------|------|----|
| 1 SIRA | Ø 3 | 25 |
| 2 SIRA | Ø 4 | 25 |
| 3 SIRA | Ø 6 | 25 |
| 4 SIRA | Ø 8 | 25 |
| 5 SIRA | Ø 10 | 25 |
| 6 SIRA | Ø 12 | 25 |

SPB



| COD | | 🛒 |
|-------|------|----|
| 1 SPB | 1/8" | 25 |
| 2 SPB | 1/4" | 25 |
| 3 SPB | 3/8" | 10 |
| 4 SPB | 1/2" | 10 |
| 5 SPB | 3/4" | 5 |
| 6 SPB | 1" | 5 |

Niplo in Nylon
Nylon nipple
Cilindrico
Parallel

SOS



| COD | | 🛒 |
|-------|------|----|
| 1 SOS | 1/8" | 25 |
| 2 SOS | 1/4" | 25 |
| 3 SOS | 3/8" | 10 |
| 4 SOS | 1/2" | 10 |
| 5 SOS | 3/4" | 5 |
| 6 SOS | 1" | 5 |

Versione bronzo nichelato: + 20%
Nickel-plated bronze version: + 20%
A richiesta in **AISI 316 L**
On request in **AISI 316 L**



Cilindrico
Parallel

SFEB



| COD | | 🛒 |
|---------|--------|----|
| 1 SFEB | 1/8" | 25 |
| 2 SFEB | 1/4" | 25 |
| 3 SFEB | 3/8" | 10 |
| 4 SFEB | 1/2" | 10 |
| 5 SFEB | 3/4" | 5 |
| 6 SFEB | 1" | 5 |
| 9 SFEB | M3 | 25 |
| 10 SFEB | M4 | 25 |
| 7 SFEB | M5 | 25 |
| 14 SFEB | M6 | 25 |
| 8 SFEB | 1/8" F | 25 |

Niplo in ottone
Filo in **AISI 304**
Brass nipple
Pressed wire **AISI 304**
Cilindrico
Parallel

SILENZIATORI - SILENCERS

SEF



| COD | | 🛒 |
|-------|------|----|
| 1 SEF | 1/8" | 25 |
| 2 SEF | 1/4" | 25 |
| 3 SEF | 3/8" | 10 |
| 4 SEF | 1/2" | 10 |
| 5 SEF | 3/4" | 5 |
| 6 SEF | 1" | 5 |
| 7 SEF | M5 | 25 |

Femmina
Female

SZ



| COD | | 🛒 |
|------|------|----|
| 1 SZ | 1/8" | 25 |
| 2 SZ | 1/4" | 25 |
| 3 SZ | 3/8" | 10 |
| 4 SZ | 1/2" | 10 |
| 7 SZ | M5 | 25 |

Cilindrico
Parallel

SPL



| COD | | 🛒 |
|-------|--------|----|
| 1 SPL | 1/8" | 25 |
| 2 SPL | 1/4" | 25 |
| 3 SPL | 3/8" | 10 |
| 4 SPL | 1/2" | 10 |
| 5 SPL | 3/4" | 5 |
| 6 SPL | 1" | 5 |
| 8 SPL | 1/8" F | 25 |

Cilindrico
Parallel

Resina acetaltica - Saldatura ad ultrasuoni - Colori: blu (standard) - nero (su richiesta)
Acetal resin - Ultrasonic welding - Colors: blue (standard) - black (on request)

SPL-F



| COD | | 🛒 |
|---------|--------|----|
| 1 SPL-F | 1/8" | 25 |
| 2 SPL-F | 1/4" | 25 |
| 3 SPL-F | 3/8" | 10 |
| 4 SPL-F | 1/2" | 10 |
| 5 SPL-F | 3/4" | 5 |
| 6 SPL-F | 1" | 5 |
| 8 SPL-F | 1/8" F | 25 |

Cilindrico
Parallel

Nylon - Colori: blu (standard) - nero (su richiesta)
Nylon - Colors: blue (standard) - black (on request)

SPL-P



| COD | | 🛒 |
|---------|------|----|
| 1 SPL-P | 1/8" | 25 |
| 2 SPL-P | 1/4" | 25 |
| 3 SPL-P | 3/8" | 10 |
| 4 SPL-P | 1/2" | 10 |
| 5 SPL-P | 3/4" | 5 |
| 6 SPL-P | 1" | 5 |
| 7 SPL-P | M5 | 25 |

Cilindrico
Parallel

Nylon + PE-HD - Colore: Bianco - Nylon + PE-HD - Color: White

SPL-G



| COD | | 🛒 |
|---------|------|----|
| 1 SPL-G | 1/8" | 25 |
| 2 SPL-G | 1/4" | 25 |
| 3 SPL-G | 3/8" | 10 |
| 4 SPL-G | 1/2" | 10 |
| 5 SPL-G | 3/4" | 5 |
| 6 SPL-G | 1" | 5 |
| 7 SPL-G | M5 | 25 |

Cilindrico
Parallel

Nylon + PE-HD - Nylon + PE-HD

SPL-PI



| COD | | 🛒 |
|----------|------|----|
| 2 SPL-PI | Ø 4 | 25 |
| 3 SPL-PI | Ø 6 | 10 |
| 4 SPL-PI | Ø 8 | 10 |
| 5 SPL-PI | Ø 10 | 5 |
| 6 SPL-PI | Ø 12 | 5 |

Nylon + PE-HD - Nylon + PE-HD

SEZ



| COD | | 🛒 |
|-------|------|----|
| 1 SEZ | 1/8" | 25 |
| 2 SEZ | 1/4" | 25 |
| 3 SEZ | 3/8" | 10 |
| 4 SEZ | 1/2" | 10 |
| 9 SEZ | M3 | 25 |
| 7 SEZ | M5 | 25 |

Cilindrico
Parallel

SER



| COD | | 🛒 |
|-------|------|----|
| 1 SER | 1/8" | 25 |
| 2 SER | 1/4" | 25 |

Cilindrico
Parallel

Retina forata AISI 304 - Nipplo: ottone
Perforated sheet: AISI 304 - Brass nipple

SERX



| COD | | 🛒 |
|---------|--------|----|
| 1 SERX | 1/8" | 25 |
| 2 SERX | 1/4" | 25 |
| 3 SERX | 3/8" | 10 |
| 4 SERX | 1/2" | 10 |
| 5 SERX | 3/4" | 5 |
| 6 SERX | 1" | 5 |
| 12 SERX | 1" 1/2 | 1 |

Cilindrico
Parallel

Retina forata AISI 304 - Nipplo: AISI 316 L
Perforated sheet: AISI 304 - Nipple: AISI 316 L

SPX



| COD | | 🛒 |
|-------|------|----|
| 1 SPX | 1/8" | 25 |
| 2 SPX | 1/4" | 25 |
| 3 SPX | 3/8" | 10 |
| 4 SPX | 1/2" | 10 |
| 5 SPX | 3/4" | 5 |
| 6 SPX | 1" | 5 |
| 7 SPX | M5 | 25 |

Cilindrico
Parallel

Filo AISI 304 - Nipplo: AISI 316 L
Pressed wire AISI 304 - Nipple: AISI 316 L

STF



| COD | | 🛒 |
|--------|--------|----|
| 1 STF | 1/8" | 25 |
| 2 STF | 1/4" | 25 |
| 3 STF | 3/8" | 10 |
| 4 STF | 1/2" | 10 |
| 5 STF | 3/4" | 5 |
| 6 STF | 1" | 5 |
| 11 STF | 1" 1/4 | 1 |
| 12 STF | 1" 1/2 | 1 |
| 13 STF | 2" | 1 |

Acciaio zincato
Galvanized steel
Cilindrico
Parallel

SEX



| COD | | 🛒 |
|-------|--------|----|
| 1 SEX | 1/8" | 25 |
| 2 SEX | 1/4" | 25 |
| 3 SEX | 3/8" | 10 |
| 4 SEX | 1/2" | 10 |
| 5 SEX | 3/4" | 5 |
| 6 SEX | 1" | 5 |
| 7 SEX | M5 | 25 |
| 8 SEX | 1/8" F | 25 |

Cilindrico
Parallel
AISI 316 L

SEX-T



| COD | | 🛒 |
|----------|--------|----|
| 1 SEX-T | 1/8" | 25 |
| 2 SEX-T | 1/4" | 25 |
| 3 SEX-T | 3/8" | 10 |
| 4 SEX-T | 1/2" | 10 |
| 5 SEX-T | 3/4" | 5 |
| 6 SEX-T | 1" | 5 |
| 12 SEX-T | 1" 1/2 | 1 |
| 13 SEX-T | 2" | 1 |
| 7 SEX-T | M5 | 25 |

Conico
Taper
AISI 316 L

SFEX



| COD | | 🛒 |
|---------|--------|----|
| 1 SFEX | 1/8" | 25 |
| 2 SFEX | 1/4" | 25 |
| 3 SFEX | 3/8" | 10 |
| 4 SFEX | 1/2" | 10 |
| 5 SFEX | 3/4" | 5 |
| 6 SFEX | 1" | 25 |
| 12 SFEX | 1" 1/2 | 1 |
| 13 SFEX | 2" | 1 |
| 9 SFEX | M3 | 25 |
| 10 SFEX | M4 | 25 |
| 7 SFEX | M5 | 25 |
| 14 SFEX | M6 | 25 |
| 8 SFEX | 1/8" F | 25 |

Cilindrico
Parallel
Filo - Pressed wire
AISI 304
Niplo - Nipple
AISI 316 L

SFEP



| COD | | 🛒 |
|--------|------|----|
| 1 SFEP | 1/8" | 25 |
| 2 SFEP | 1/4" | 25 |
| 3 SFEP | 3/8" | 10 |
| 4 SFEP | 1/2" | 10 |
| 5 SFEP | 3/4" | 5 |
| 6 SFEP | 1" | 5 |

Cilindrico
Parallel
Niplo - Nipple
UPVC
Filo - Pressed wire
AISI 304

Saldatura ad ultrasuoni
Ultrasonic welding

SEPX



| COD | | 🛒 |
|---------|--------|----|
| 1 SEPX | 1/8" | 25 |
| 2 SEPX | 1/4" | 25 |
| 3 SEPX | 3/8" | 10 |
| 4 SEPX | 1/2" | 10 |
| 5 SEPX | 3/4" | 5 |
| 6 SEPX | 1" | 5 |
| 12 SEPX | 1" 1/2 | 1 |
| 13 SEPX | 2" | 1 |
| 7 SEPX | M5 | 25 |

Cilindrico
Parallel
AISI 316 L

SPV - VACUUM



| COD | | 🛒 |
|-------|------|----|
| 1 SPV | 1/8" | 25 |
| 2 SPV | 1/4" | 25 |
| 3 SPV | 3/8" | 10 |
| 4 SPV | 1/2" | 10 |
| 5 SPV | 3/4" | 5 |
| 6 SPV | 1" | 5 |

Cilindrico
Parallel

Nylon + PE-HD - Nylon + PE-HD

ECO-1



| COD | | 🛒 |
|---------|--|---|
| 1 ECO-1 | | 1 |

Nylon - Scarico centralizzato - Multi Inlet
Nylon - Centralized drain - Multi Inlet

ECO-S



| COD | | 🛒 |
|---------|------|---|
| 1 ECO-S | 1/8" | 1 |
| 2 ECO-S | 1/4" | 1 |
| 3 ECO-S | 3/8" | 1 |
| 4 ECO-S | 1/2" | 1 |
| 5 ECO-S | 3/4" | 1 |
| 6 ECO-S | 1" | 1 |

Cilindrico
Parallel

Nylon - Scarico centralizzato
Nylon - Centralized drain

ECO-C



| COD | | 🛒 |
|---------|------|---|
| 1 ECO-C | 1/8" | 1 |
| 2 ECO-C | 1/4" | 1 |
| 3 ECO-C | 3/8" | 1 |
| 4 ECO-C | 1/2" | 1 |
| 5 ECO-C | 3/4" | 1 |
| 6 ECO-C | 1" | 1 |

Cilindrico
Parallel

Nylon - Filtro / silenziatore coalescente - Ricambi a richiesta
Nylon - Coalescing Filter Muffler - Spare parts available on request

SX-C



| COD | | 🛒 |
|--------|------|---|
| 1 SX-C | 1/8" | 1 |
| 2 SX-C | 1/4" | 1 |
| 3 SX-C | 3/8" | 1 |
| 4 SX-C | 1/2" | 1 |
| 5 SX-C | 3/4" | 1 |

Cilindrico
Parallel

Filtro / silenziatore coalescente - Ricambi a richiesta
Coalescing Filter Muffler - Spare parts available on request

Disponibili a richiesta: Versione nichelata - Filetto NPT - Filetti speciali
Available on request: Nickel-plated version - NPT thread - Special threads

SILENZIATORI - SILENCERS

SAE - SILENZIATORI AD ALTA EFFICIENZA - HIGH EFFICIENCY SILENCERS

| COD | INCH | mm |
|--------|-------|----|
| 1 SAE | 1/8" | 25 |
| 2 SAE | 1/4" | 25 |
| 3 SAE | 3/8" | 10 |
| 4 SAE | 1/2" | 10 |
| 5 SAE | 3/4" | 5 |
| 6 SAE | 1" | 5 |
| 11 SAE | 1"1/4 | 1 |
| 12 SAE | 1"1/2 | 1 |
| 13 SAE | 2" | 1 |



Cilindrico
Parallelo

Elemento filtrante in fibra di cellulosa impregnata di fenolo.

Filter element: cellulose fiber impregnated with phenol.

A richiesta disponibili le dimensioni da 3" - 4" - 6" a camera di espansione multipla.

Sizes 3" - 4" - 6" (with multiple expansion chamber) available on request.

A RICHIESTA VERSIONE 40 BAR - LISTINO + 35%
40 BAR VERSION ON REQUEST - PRICE LIST + 35%

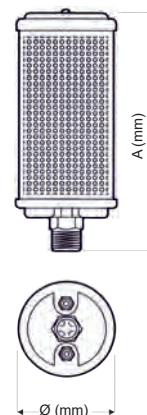

| | A (mm) | Ø (mm) | Kg |
|-------|--------|--------|------|
| 1/8" | 76,20 | 47,62 | 0,11 |
| 1/4" | 101,65 | 47,62 | 0,14 |
| 3/8" | 120,65 | 66,67 | 0,23 |
| 1/2" | 139,70 | 82,55 | 0,28 |
| 3/4" | 171,45 | 85,72 | 0,34 |
| 1" | 203,20 | 98,42 | 0,45 |
| 1"1/4 | 209,65 | 98,42 | 0,45 |
| 1"1/2 | 336,55 | 130,17 | 1,81 |
| 2" | 463,55 | 130,17 | 2,27 |

Disponibili a richiesta: Versione nichelata - Filetto NPT - Filetti speciali
Available on request: Nickel-plated version - NPT thread - Special threads

SAI - SILENZIATORE DI SICUREZZA ANTI INTASAMENTO - ANTI-CLOGGING SAFETY SILENCER

| COD | INCH | mm |
|--------|-------|----|
| 4 SAI | 1/2" | 1 |
| 5 SAI | 3/4" | 1 |
| 6 SAI | 1" | 1 |
| 12 SAI | 1"1/2 | 1 |
| 13 SAI | 2" | 1 |



Cilindrico
Parallelo

MATERIALE:

Corpo: Ottone
Elemento filtrante: Bronzo sferico

PRESSIONE: 20 Bar

MATERIAL:

Body: Brass
Filter element: Spherical bronze

PRESSURE: 20 Bar

80% ABBATTIMENTO ACUSTICO
80% NOISE REDUCTION

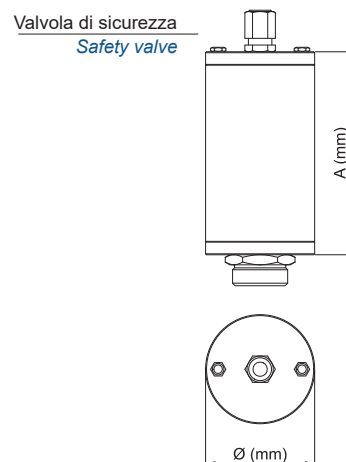

| | A (mm) | Ø (mm) |
|-------|--------|--------|
| 1/2" | 125,00 | 64,5 |
| 3/4" | 175,00 | 64,5 |
| 1" | 225,00 | 64,5 |
| 1"1/2 | 325,00 | 64,5 |
| 2" | 425,00 | 64,5 |

Per maggiori chiarimenti e specifiche consultare il relativo Fascicolo Tecnico.
For further clarifications and specifications consult the relevant Technical File.

SAP- FILTRO SILENZIATORE IN TECNOPOLIMERO - *PLASTIC SILENCER FILTER*

| COD | | 🛒 |
|------------|-------|----|
| 1 SAP | 1/8" | 25 |
| 2 SAP | 1/4" | 25 |
| 3 SAP | 3/8" | 10 |
| 4 SAP | 1/2" | 10 |
| 5 SAP | 3/4" | 5 |
| 6 SAP | 1" | 5 |
| 6 SAP-MAX | 1" | 1 |
| 11 SAP-MAX | 1"1/4 | 1 |
| 12 SAP-MAX | 1"1/2 | 1 |
| 13 SAP-MAX | 2" | 1 |
| 7 SAP | M5 | 25 |

| COD | D (mm) | H (mm) | C (mm) |
|------------------|--------|--------|--------|
| 1 SAP 1/8" | 15.7 | 39 | 25 |
| 2 SAP 1/4" | 20 | 64 | 17.4 |
| 3 SAP 3/8" | 24.6 | 83 | 21 |
| 4 SAP 1/2" | 30 | 92 | 24 |
| 5 SAP 3/4" | 44 | 99 | 32 |
| 6 SAP 1" | 44 | 99 | 32 |
| 6 SAP-MAX 1" | 85 | 205 | 38 |
| 11 SAP-MAX 1"1/4 | 97 | 250 | 49 |
| 12 SAP-MAX 1"1/2 | 95 | 270 | 53 |
| 13 SAP-MAX 2" | 112 | 300 | 68 |
| 7 SAP M5 | 8,2 | 18 | 8 |

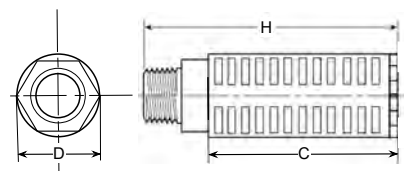

1 SAP 1/8"
2 SAP 1/4"
3 SAP 3/8"
4 SAP 1/2"
5 SAP 3/4"
6 SAP 1"



7 SAP M5

6 SAP-MAX 1"
11 SAP-MAX 1"1/4
12 SAP-MAX 1"1/2
13 SAP-MAX 2"

Cilindrico
Parallel

SPL-R

| COD | | 🛒 |
|---------|------|----|
| 1 SPL-R | 1/8" | 10 |
| 2 SPL-R | 1/4" | 10 |
| 3 SPL-R | 3/8" | 10 |
| 4 SPL-R | 1/2" | 10 |
| 5 SPL-R | 3/4" | 5 |
| 6 SPL-R | 1" | 5 |

| COD | A | CH | C | F | L | gr. |
|---------|------|----|------|----|-----|------|
| 1 SPL-R | 1/8" | 10 | 15,5 | 6 | 27 | 3 |
| 2 SPL-R | 1/4" | 12 | 19,5 | 8 | 35 | 6,3 |
| 3 SPL-R | 3/8" | 16 | 24,5 | 11 | 47 | 12,3 |
| 4 SPL-R | 1/2" | 16 | 24,5 | 11 | 47 | 13,6 |
| 5 SPL-R | 3/4" | 25 | 50 | 18 | 100 | 88,1 |
| 6 SPL-R | 1" | 25 | 50 | 18 | 100 | 93,2 |

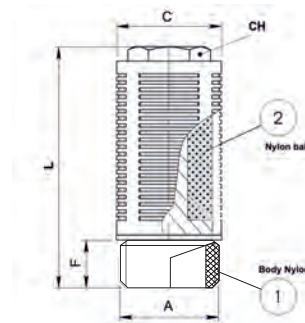

Cilindrico
Parallel

Pressione di esercizio: Max 12 Bar
Operating pressure: Max 12 Bar

DINAMICO
DYNAMIC

SDC - SILENZIATORE A DOPPIA CAMERA - *DOUBLE CHAMBER SILENCER*

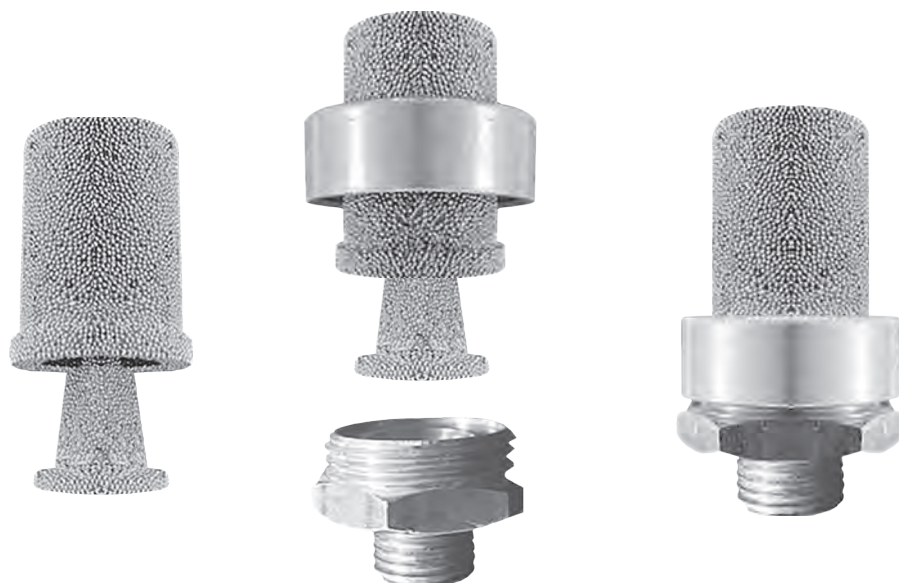

| COD | A | CH | F | H | 🛒 |
|-------|------|----|----|----|----|
| 1 SDC | 1/8" | 16 | 8 | 40 | 25 |
| 2 SDC | 1/4" | 16 | 8 | 40 | 25 |
| 3 SDC | 3/8" | 24 | 11 | 50 | 10 |
| 4 SDC | 1/2" | 24 | 11 | 50 | 10 |
| 5 SDC | 3/4" | 36 | 15 | 75 | 5 |
| 6 SDC | 1" | 36 | 15 | 75 | 5 |

Standard: bronzo sinterizzato - A richiesta: versione nichelata
Standard: sintered bronze - On request: nickel-plated version

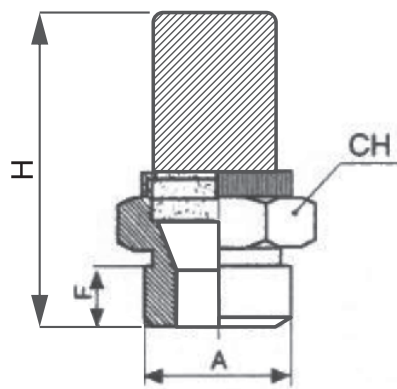

KIT PER SILENZIATORE ECO-S - *ECO-S SILENCER KIT*

SILENZIATORE ECO-S
ECO-S SILENCER



KIT
KIT

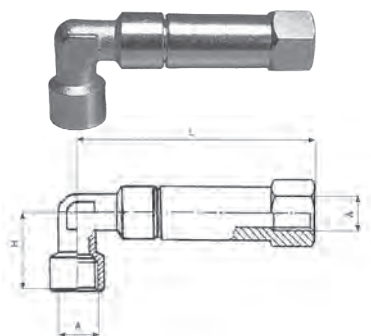

| COD | A | L | H | 🛒 |
|-------|------|----|----|---|
| 1 KIT | 1/8" | 50 | 19 | 1 |
| 2 KIT | 1/4" | 50 | 25 | 1 |
| 3 KIT | 3/8" | 60 | 28 | 1 |
| 4 KIT | 1/2" | 60 | 33 | 1 |
| 5 KIT | 3/4" | 75 | 36 | 1 |
| 6 KIT | 1" | 75 | 37 | 1 |

SOS - SILENZIATORE CON ORIENTATORE DI SCARICO - SILENCER WITH EXHAUST ORIENTER

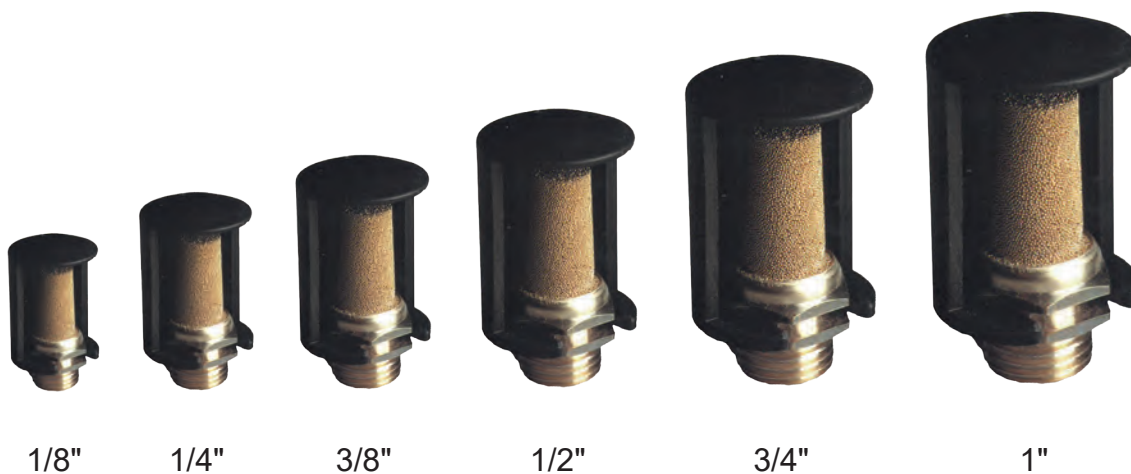

1/8"

1/4"

3/8"

1/2"

3/4"

1"

Il cappuccio protettivo - deviatore viene inserito dopo il montaggio del silenziatore, consentendo la possibilità di orientare lo scarico dell'aria.

Il silenziatore modello SOS, ideato, prodotto e commercializzato dalla SAS Sinterizzati s.r.l. può essere utilizzato negli utensili pneumatici manuali per evitare che lo scarico dell'aria colpisca l'operatore che utilizza l'utensile stesso.

In postazioni fisse di lavoro, deviando lo scarico dell'aria proveniente da elettrovalvole ed accessori pneumatici che utilizzano, per il loro funzionamento aria compressa, il modello SOS evita che lo scarico stesso crei disagio all'operatore.

The protective cap - diverter is inserted after mounting the silencer, allowing the possibility of directing the air exhaust. The SOS model silencer, designed, produced and marketed by SAS Sinterizzate s.r.l. It can be used in manual pneumatic tools to prevent the air exhaust from hitting the operator who uses the tool itself.

In fixed workstations, by diverting the air exhaust coming from solenoid valves and pneumatic accessories that use compressed air for their operation, the SOS model prevents the exhaust itself from creating discomfort for the operator.



Nipple
Nipple

+



Filter
Filter

▶



Silenzatore
Silencer

+



Orientatore
Protective cap

▶



SOS

Parte libera di ruotare
su 360 gradi
*Part free to rotate
360 degrees*

←
Parte montata
e bloccata
*Part assembled
and blocked*

ECO-C - FILTRO SILENZIATORE A COALESCENZA - COALESCENCE SILENCER FILTER

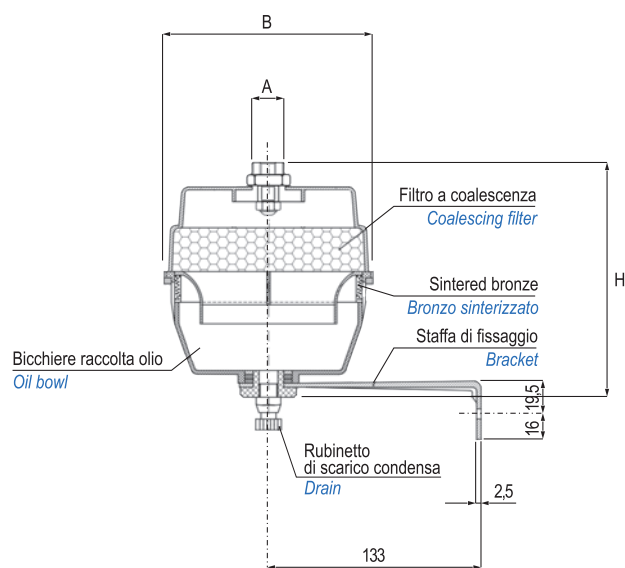

| COD | A | B | H | gr. | 🛒 |
|---------|------|-----|-----|-----|---|
| 1 ECO-C | 1/8" | 65 | 68 | 123 | 1 |
| 2 ECO-C | 1/4" | 65 | 68 | 128 | 1 |
| 3 ECO-C | 3/8" | 95 | 95 | 236 | 1 |
| 4 ECO-C | 1/2" | 95 | 95 | 246 | 1 |
| 5 ECO-C | 3/4" | 131 | 134 | 664 | 1 |
| 6 ECO-C | 1" | 131 | 134 | 674 | 1 |

Ricambi a richiesta
Spare parts on request

| COD | A | B | H | gr. | 🛒 |
|---------|------|-----|-----|-----|---|
| 1 ECO-C | 1/8" | 65 | 68 | 123 | 1 |
| 2 ECO-C | 1/4" | 65 | 68 | 128 | 1 |
| 3 ECO-C | 3/8" | 95 | 95 | 236 | 1 |
| 4 ECO-C | 1/2" | 95 | 95 | 246 | 1 |
| 5 ECO-C | 3/4" | 131 | 134 | 664 | 1 |
| 6 ECO-C | 1" | 131 | 134 | 674 | 1 |

SX-C - FILTRO SILENZIATORE A COALESCENZA - COALESCENCE SILENCER FILTER

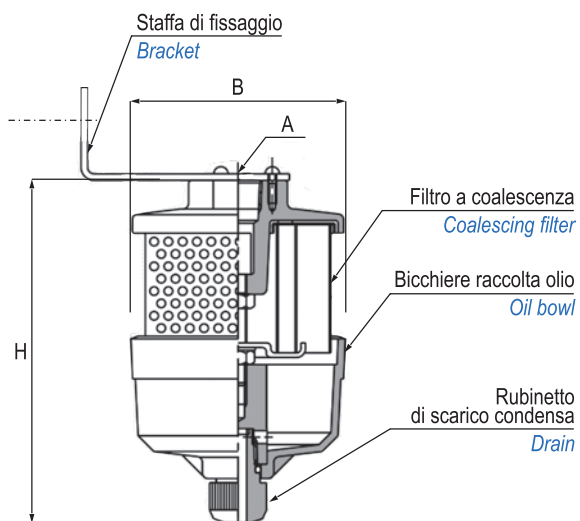

| COD | A | B | H | gr. | 🛒 |
|--------|------|-----|-----|-----|---|
| 1 SX-C | 1/8" | 56 | 88 | 120 | 1 |
| 2 SX-C | 1/4" | 56 | 88 | 120 | 1 |
| 3 SX-C | 3/8" | 75 | 121 | 200 | 1 |
| 4 SX-C | 1/2" | 102 | 174 | 500 | 1 |
| 5 SX-C | 3/4" | 102 | 174 | 500 | 1 |

Ricambi a richiesta
Spare parts on request

| COD | A | B | H | gr. | 🛒 |
|--------|------|-----|-----|-----|---|
| 1 SX-C | 1/8" | 56 | 88 | 120 | 1 |
| 2 SX-C | 1/4" | 56 | 88 | 120 | 1 |
| 3 SX-C | 3/8" | 75 | 121 | 200 | 1 |
| 4 SX-C | 1/2" | 102 | 174 | 500 | 1 |
| 5 SX-C | 3/4" | 102 | 174 | 500 | 1 |

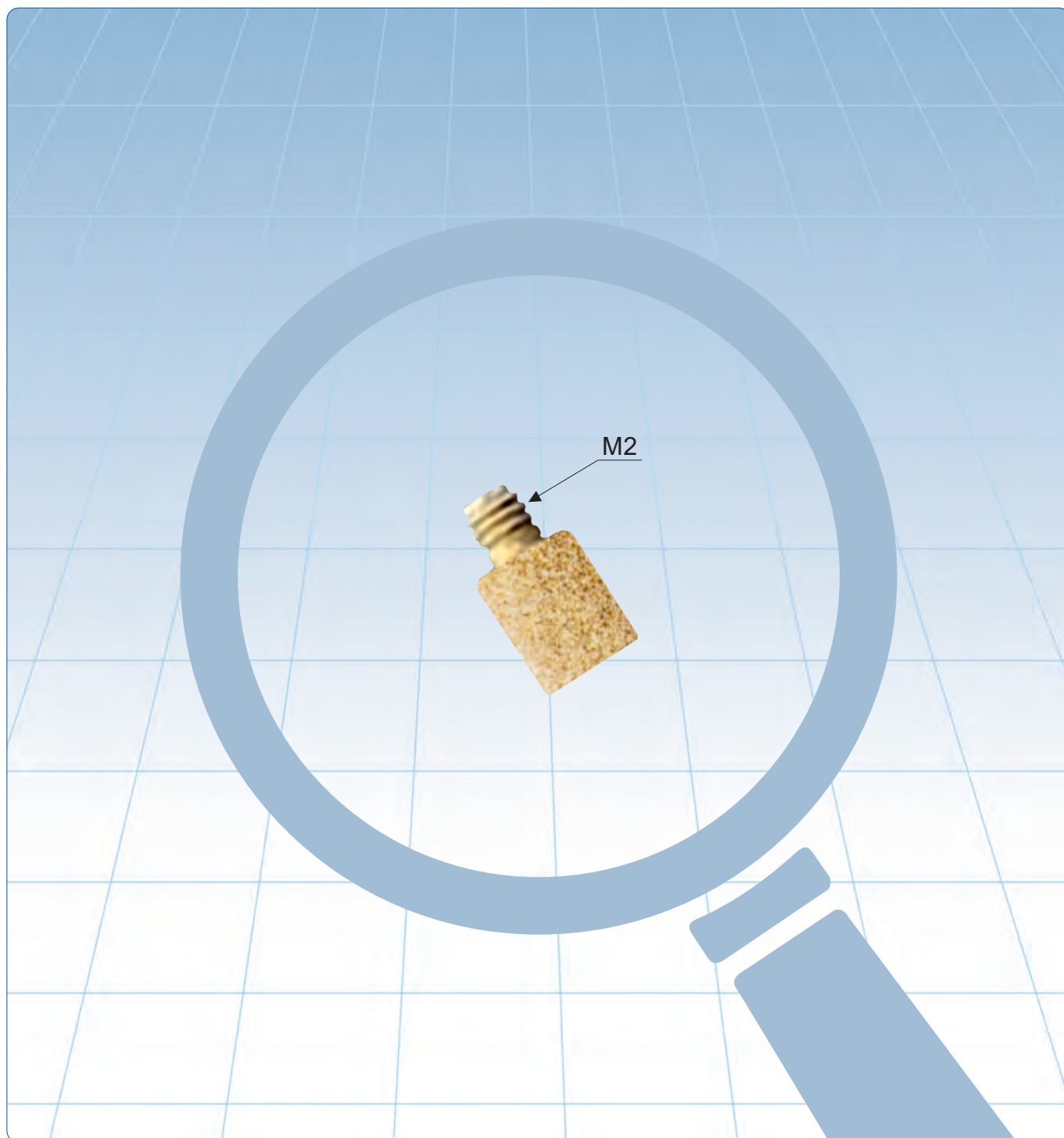

SILENZIATORE TIPO M2 - *M2 TYPE SILENCER*

| TABELLA DIMENSIONALE FILETTATURE PASSO GAS - <i>GAS PITCH THREADING TABLE</i> | |
|---|--|
| Ø NOMINALE IN POLLICI <i>NOMINAL Ø IN INCHES</i> | Ø ESTERNO TEORICO DEL FILETTO <i>THEORETICAL EXTERNAL Ø OF THE THREAD</i> |
| 1/8" | 9,72 |
| 1/4" | 13,15 |
| 3/8" | 16,66 |
| 1/2" | 20,95 |
| 3/4" | 26,44 |
| 1" | 33,24 |
| 1"1/4" | 41,91 |
| 1"1/2" | 47,80 |
| 1"3/4" | 53,74 |
| 2" | 59,61 |
| 2"1/4" | 69,30 |
| 2"1/2" | 75,18 |
| 2"3/4" | 81,53 |
| 3" | 87,88 |
| 3"1/2" | 100,33 |
| 4" | 113,03 |

LE DIMENSIONI DEI CERCHI
SOTTO RIPORTATI
CORRISPONDONO A QUELLE REALI

*DIMENSIONS OF CIRCLES
CORRESPOND
TO THE REAL ONES*

GRAFICO LIVELLO SONORO SCARICO LIBERO SENZA SILENZIATORE - *SOUND LEVEL FREE EXHAUST*



GRAFICO LIVELLO SONORO A SCARICO LIBERO E A SCARICO SILENZIATO - *SOUND LEVEL WITH EXHAUST / FREE EXHAUST*





I Tutti i modelli del presente catalogo possono essere forniti anche con filettatura NPT e Nichelati.
La granulometria del bronzo sferico può essere variata su richiesta e per quantitativi.
Pressione massima di utilizzo: 12 bar - Temperatura massima: + 80 °C - Temperatura minima: - 10 °C
Si consiglia di utilizzare il silenziatore modello SPL alla pressione massima di 6 bar.
Le caratteristiche e le dimensioni riportate nel presente catalogo si intendono non impegnative.

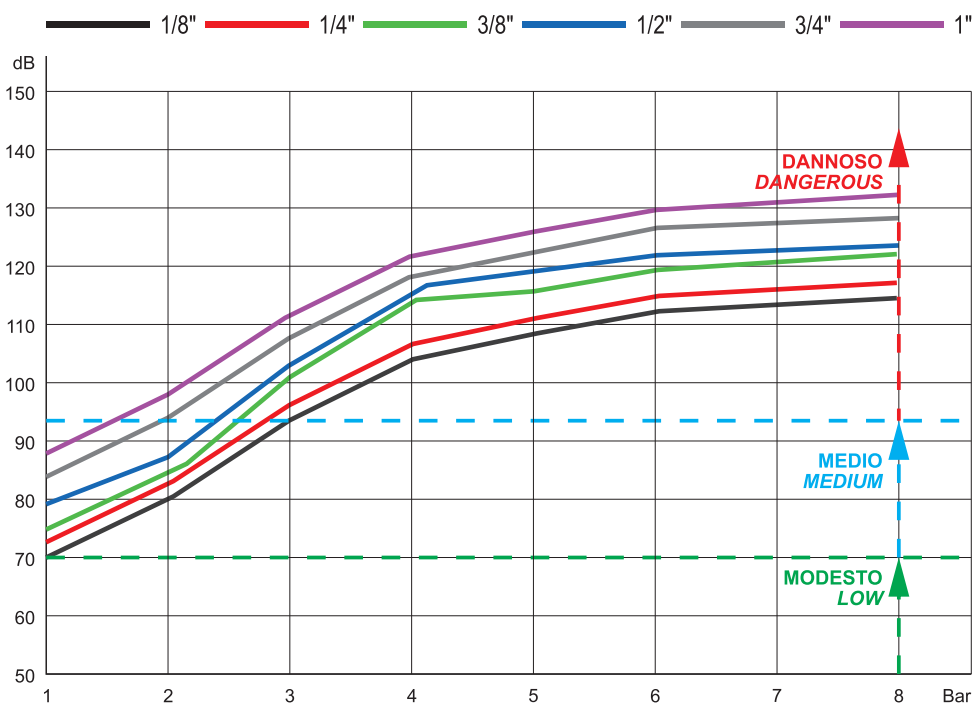
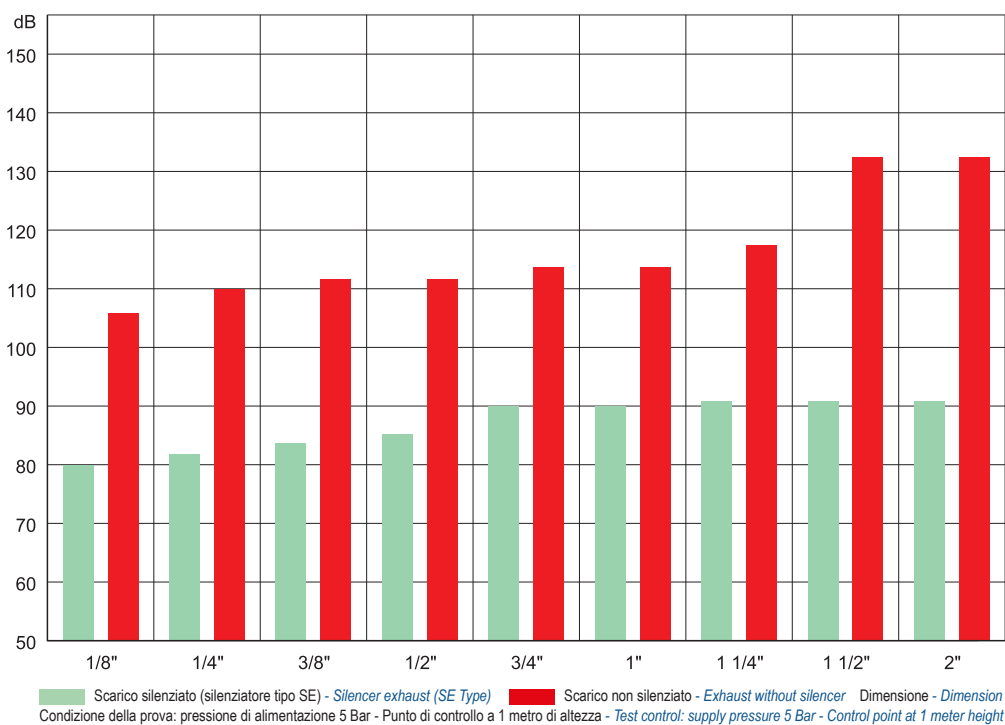

GB All the models in this catalogue can be supplied also with NPT threading and Nickel-plated.
Spherical bronze size can be changed on request and for quantities.
Maximum pressure: 12 bar - Maximum temperature: + 80 °C - Lowest temperature: -10 °C
We advise to use the type SPL silencer at the maximum pressure of 6 bar.
Characteristics and dimensions specified in this catalogue are not binding.



FR Tous les pièces reprises au catalogue peuvent être fournies nickelées ou avec un filet NPT.
Les silencieux SPL ne peuvent être utilisés pour une pression supérieure a 6 bar.
Sur demande et par quantités, la dimension des grains de bronze frittés peut être modifiée, conditions d'utilisation:
Pression maximum: 12 bar - Température maximum: + 80 °C - Température minimum: -10 °C
Les caractéristiques et les dimensions indiquées dans ce catalogue ne nous engagent pas.



D Alle Modelle in diesem Katalog können auch mit NPT-Gewinde und vernickelt geliefert werden.
Sphärische Bronze: Abweichende Größen und Stückzahlen sind auf Anfrage möglich.
Maximaler Druck: 12 bar - Maximale Temperatur: + 80 °C - Minimale Temperatur: - 10 °C
Wir empfehlen, den Schalldämpfer Typ SPL mit einem maximalen Druck von 6 bar zu verwenden.
Die in diesem Katalog angegebenen Eigenschaften und Abmessungen sind nicht verbindlich



E Todos los modelos en éste catálogo también se pueden suministrar con NPT y Niquelados.
La granulometría del bronce esférico se puede variar a pedido y por cantidades.
Presión máxima de funcionamiento: 12 bar - Temperatura máxima: + 80 °C - Temperatura mínima: - 10 °C
Se recomienda usar el silenciador del modelo SPL a una presión máxima de 6 bar.
Las características y dimensiones que se muestran en éste catálogo no son vinculantes.



P Todos los modelos deste catálogo podem ser fornecidos também com rosca em NPT e niquelado. A granulometria do bronze esférico pode ser variada sob encomenda e quantidade.
Pressão máxima: 12 bar - Temperatura máxima: + 80 °C - Temperatura mínima: - 10 °C
Aconselha-se o uso de silenciador modelo SPL com pressão máxima de 6 bar. As características e as dimensões especificadas neste catálogo não são vinculativas.



S Samtliga modeller i denna katalog kan även erhållas med npt-gåncor och förnicklat utförande. Sinter-bronsets Kornstorlek kan ändras vid förfrågan. max arbetstryck: 12 bar - max temperatur: +80 °C. - min temperatur: -10 °C. vid användning av spilljuddämpare are rekommenderas ett max tryck av 6 bar. Tekniska anvisningar och dimensionerangivna i denna katalog är inte bindande.



DK Alle modellerne i dette katalog kan leveres med npt gevind og forniklet. Porestørrelse på sinterbronze kan ændres ved forespørgsel og større stykta. Lyddæmperne 2961 (spl) i kunststof bør ikke anvendes ved tryk over 6 bar.



RC 本说明书中所有的型号都可提供，其中包括NPT螺纹和镀镍。青铜球规格和数量可按顾客的要求改变。
最大使用压力：12巴；最高温度：80℃；最低温度：10℃。
建议采用最大压力6巴SPL型消音器。此说明书中阐述的特点和规格仅供参考。





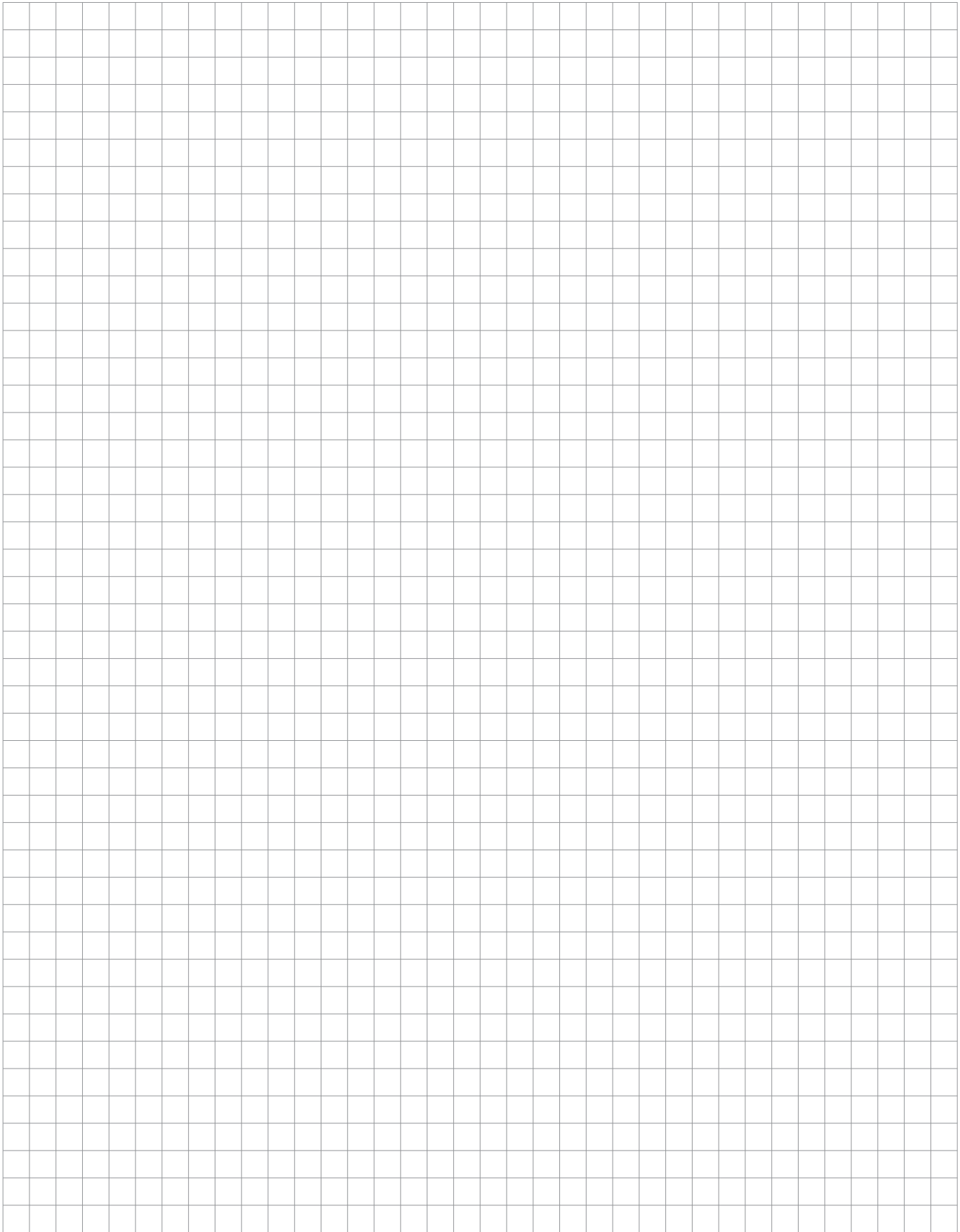

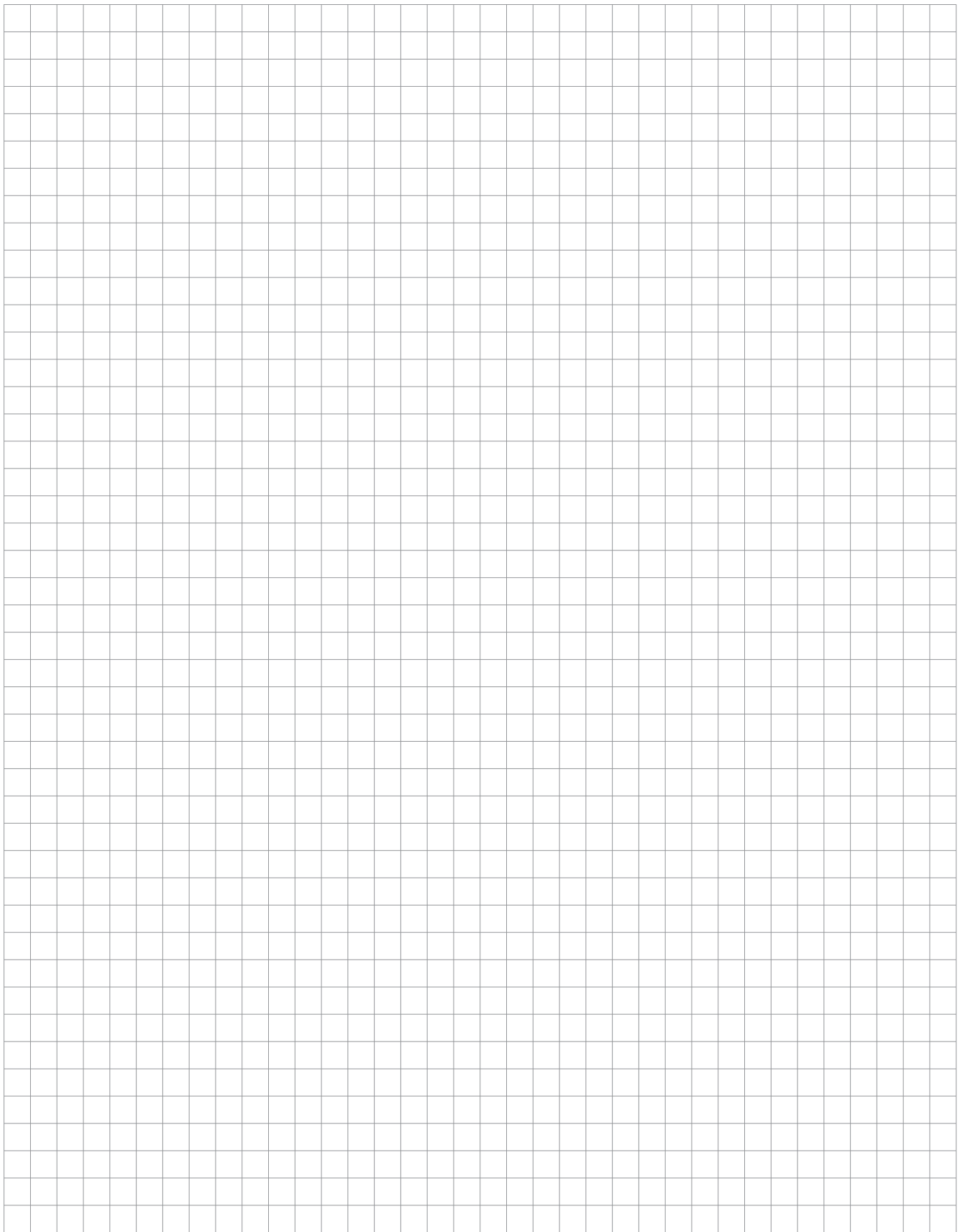



GR Όλα τα μοντέλα σε αυτόν τον κατάλογο προσφέρονται επίσης με NPT σπείρωμα επινικελωμένο.
Η κοκκομετρία του σφαιρικού χαλκού μπορεί να μεταβάλλεται κατόπιν αιτήματος και για ποσότητες.
Μέγιστη πίεση λειτουργίας: 12 bar - Μέγιστη θερμοκρασία: + 80 °C - Ελάχιστη θερμοκρασία: - 10 °C.
Συνιστούμε τη χρήση του σιγαστήρα μοντέλου SPL σε μέγιστη πίεση 6 bar.
Τα χαρακτηριστικά και οι διαστάσεις που παρουσιάζονται σε αυτόν τον κατάλογο δεν είναι δεσμευτικές.







REGULATORS

| | | | | | |
|---|-------|----|--|-----------|----|
|  | SVE | 57 |  | SV-X | 57 |
|  | SVEX | 57 |  | SVT | 58 |
|  | SVR | 57 |  | SVP | 58 |
|  | SVRX | 57 |  | RFL-U | 58 |
|  | SVL | 57 |  | ESA | 58 |
|  | SVL-X | 57 |  | DSN | 58 |
|  | DVE | 57 |  | DSP | 58 |
|  | DS | 57 |  | R-SC | 58 |
|  | DSP-M | 57 |  | RX-SC | 58 |
|  | DSE | 57 |  | ESL/ESL-B | 58 |
|  | SVS | 57 |  REGOLATORI DI FLUSSO GRADUATI GRADUATED FLOW REGULATORS | | 59 |

SVE



| COD | | 🛒 |
|-------|------|----|
| 1 SVE | 1/8" | 25 |
| 2 SVE | 1/4" | 25 |
| 3 SVE | 3/8" | 10 |
| 4 SVE | 1/2" | 10 |
| 5 SVE | 3/4" | 5 |
| 6 SVE | 1" | 5 |
| 7 SVE | M5 | 25 |

Cilindrico
Parallel

SVEX



| COD | | 🛒 |
|--------|------|----|
| 1 SVEX | 1/8" | 25 |
| 2 SVEX | 1/4" | 25 |
| 3 SVEX | 3/8" | 10 |
| 4 SVEX | 1/2" | 10 |
| 5 SVEX | 3/4" | 5 |
| 6 SVEX | 1" | 5 |
| 7 SVEX | M5 | 25 |

Cilindrico
Parallel
INOX AISI 316 L

SVR



| COD | | 🛒 |
|-------|------|----|
| 1 SVR | 1/8" | 25 |
| 2 SVR | 1/4" | 25 |
| 3 SVR | 3/8" | 10 |
| 4 SVR | 1/2" | 10 |

Cilindrico
Parallel

SVRX



| COD | | 🛒 |
|--------|------|----|
| 1 SVRX | 1/8" | 25 |
| 2 SVRX | 1/4" | 25 |
| 3 SVRX | 3/8" | 10 |
| 4 SVRX | 1/2" | 10 |

Cilindrico
Parallel
INOX AISI 316 L OR / VITON - OR / VITON

SVL



| COD | | 🛒 |
|-------|------|----|
| 1 SVL | 1/8" | 25 |
| 2 SVL | 1/4" | 25 |
| 3 SVL | 3/8" | 10 |
| 4 SVL | 1/2" | 10 |
| 5 SVL | 3/4" | 5 |
| 6 SVL | 1" | 5 |
| 7 SVL | M5 | 25 |

Cilindrico
Parallel

SVL-X



| COD | | 🛒 |
|---------|------|----|
| 1 SVL-X | 1/8" | 25 |
| 2 SVL-X | 1/4" | 25 |
| 3 SVL-X | 3/8" | 10 |
| 4 SVL-X | 1/2" | 10 |
| 5 SVL-X | 3/4" | 5 |
| 6 SVL-X | 1" | 5 |
| 7 SVL-X | M5 | 25 |

Cilindrico
Parallel
INOX AISI 316 L

DVE



| COD | | 🛒 |
|-------|------|----|
| 1 DVE | 1/8" | 25 |
| 2 DVE | 1/4" | 25 |

Cilindrico
Parallel

DS



| COD | | 🛒 |
|------|------|----|
| 1 DS | 1/8" | 25 |
| 2 DS | 1/4" | 25 |

DSP-M



| COD | | 🛒 |
|---------|------|----|
| 1 DSP-M | 1/8" | 25 |
| 2 DSP-M | 1/4" | 25 |

Cilindrico
Parallel

DSE



| COD | | 🛒 |
|-------|------|----|
| 1 DSE | 1/8" | 25 |
| 2 DSE | 1/4" | 25 |

Cilindrico
Parallel

SVS



| COD | | 🛒 |
|-------|------|----|
| 1 SVS | 1/8" | 25 |
| 2 SVS | 1/4" | 25 |
| 3 SVS | 3/8" | 10 |
| 4 SVS | 1/2" | 10 |

Cilindrico
Parallel

A - Filtro in PE-HD: STANDARD - HD-PE Filter: STANDARD
B - Filtro in bronzo: A RICHIESTA - Bronze Filter: ON REQUEST

SV-X



| COD | | 🛒 |
|--------|------|----|
| 1 SV-X | 1/8" | 25 |
| 2 SV-X | 1/4" | 25 |
| 3 SV-X | 3/8" | 10 |
| 4 SV-X | 1/2" | 10 |
| 5 SV-X | 3/4" | 5 |

Cilindrico
Parallel
INOX AISI 316 L

REGOLATORI - REGULATORS

SVT

Cilindrico
Parallel

| COD | | 🛒 |
|-------|------|----|
| 1 SVT | 1/8" | 25 |
| 2 SVT | 1/4" | 25 |
| 3 SVT | 3/8" | 10 |
| 4 SVT | 1/2" | 10 |

SVP

Cilindrico
Parallel

| COD | | 🛒 |
|-------|------|----|
| 1 SVP | 1/8" | 25 |
| 2 SVP | 1/4" | 25 |
| 3 SVP | 3/8" | 10 |
| 4 SVP | 1/2" | 10 |
| 7 SVP | M5 | 25 |

RFL-U

Femmina
Female

| COD | | 🛒 |
|---------|------|---|
| 1 RFL-U | 1/8" | 5 |
| 2 RFL-U | 1/4" | 5 |
| 3 RFL-U | 3/8" | 2 |
| 4 RFL-U | 1/2" | 2 |
| 5 RFL-U | 3/4" | 1 |
| 6 RFL-U | 1" | 1 |

ESA



| COD | | 🛒 |
|--------|--|----|
| 4 ESA | | 10 |
| 6 ESA | | 10 |
| 8 ESA | | 10 |
| 10 ESA | | 10 |
| 12 ESA | | 10 |

DSN

Cilindrico
Parallel

| COD | | 🛒 |
|-------|------|----|
| 1 DSN | 1/8" | 25 |
| 2 DSN | 1/4" | 25 |
| 3 DSN | 3/8" | 25 |

DSP

Cilindrico
Parallel

| COD | | 🛒 |
|-------|------|----|
| 1 DSP | 1/8" | 25 |
| 2 DSP | 1/4" | 25 |

R-SC

Cilindrico
Ottone nichelato
Parallel
Nickel Plated Brass

| COD | | 🛒 |
|---------|------|----|
| 4 R-SC | M5 | 10 |
| 4 R-SC | 1/8" | 10 |
| 6 R-SC | 1/8" | 10 |
| 6 R-SC | 1/4" | 10 |
| 8 R-SC | 1/8" | 10 |
| 8 R-SC | 1/4" | 10 |
| 10 R-SC | 1/4" | 10 |
| 10 R-SC | 1/2" | 10 |
| 12 R-SC | 1/2" | 10 |

RX-SC

Cilindrico
Parallel
AISI 316 L

| COD | | 🛒 |
|----------|------|----|
| 4 RX-SC | M5 | 10 |
| 4 RX-SC | 1/8" | 10 |
| 6 RX-SC | 1/8" | 10 |
| 6 RX-SC | 1/4" | 10 |
| 8 RX-SC | 1/8" | 10 |
| 8 RX-SC | 1/4" | 10 |
| 10 RX-SC | 1/4" | 10 |
| 10 RX-SC | 1/2" | 10 |
| 12 RX-SC | 1/2" | 10 |
| 14 RX-SC | 1/4" | 10 |
| 14 RX-SC | 1/2" | 10 |
| 16 RX-SC | 1/2" | 10 |

ESL/ESL-B

Conico Teflonato
Cilindrico con OR +10%
ESL: per cilindro
ESL-B: per valvola
Taper: Teflon Coated
Parallel (with OR): + 20%
ESL Type: for cylinders
ESL-B Type: for valves

| COD | | 🛒 |
|--------|------|----|
| 4 ESL | M5 | 10 |
| 4 ESL | 1/8" | 10 |
| 6 ESL | 1/8" | 10 |
| 6 ESL | 1/4" | 10 |
| 8 ESL | 1/8" | 10 |
| 8 ESL | 1/4" | 10 |
| 8 ESL | 3/8" | 10 |
| 10 ESL | 1/4" | 10 |
| 10 ESL | 3/8" | 10 |
| 10 ESL | 1/2" | 10 |
| 12 ESL | 3/8" | 10 |
| 12 ESL | 1/2" | 10 |

Disponibili a richiesta: Versione nichelata - Filetto NPT - Filetti speciali
Available on request: Nickel-plated version - NPT thread - Special threads



PER VALVOLE - FOR VALVES

Valvola
Valve



Simboli della direzione del flusso sul corpo
Flow direction symbols on body



PER CILINDRI - FOR CYLINDERS

Cilindro
Cylinder



Simboli della direzione del flusso sul corpo
Flow direction symbols on body



TUBO TUBO - TUBE TO TUBE

Tubo Tubo
Tube to tube



Simboli della direzione del flusso sul corpo
Flow direction symbols on body

SAS PER VALVOLE - FOR VALVES



| COD. | DIMENSIONI DEL TUBO <i>TUBE SIZE</i> | FILETTO <i>THREAD</i> |  |
|-------------------|---|--------------------------|--|
| SAS1201FS-M5-02SV | Ø 2 | M5x0.8 | 10 |
| SAS1201FS-M5-03SV | Ø 3 | M5x0.8 | 10 |
| SAS1201FS-M5-04SV | Ø 4 | M5x0.8 | 10 |
| SAS1201FS-M5-05SV | Ø 5 | M5x0.8 | 10 |
| SAS1201FS-M5-06SV | Ø 6 | M5x0.8 | 10 |
| SAS2201FS-01-04V | Ø 4 | 1/8" | 10 |
| SAS2201FS-01-06V | Ø 6 | 1/8" | 10 |
| SAS2201FS-01-08V | Ø 8 | 1/8" | 10 |
| SAS2201FS-01-10V | Ø 10 | 1/8" | 10 |

Conico Teflonato
Taper: Teflon Coated

SAS PER CILINDRI - FOR CYLINDERS



| COD. | DIMENSIONI DEL TUBO <i>TUBE SIZE</i> | FILETTO <i>THREAD</i> |  |
|-------------------|---|--------------------------|---|
| SAS1201FS-M5-02SC | Ø 2 | M5x0.8 | 10 |
| SAS1201FS-M5-03SC | Ø 3 | M5x0.8 | 10 |
| SAS1201FS-M5-04SC | Ø 4 | M5x0.8 | 10 |
| SAS1201FS-M5-05SC | Ø 5 | M5x0.8 | 10 |
| SAS1201FS-M5-06SC | Ø 6 | M5x0.8 | 10 |
| SAS2201FS-01-04C | Ø 4 | 1/8" | 10 |
| SAS2201FS-01-06C | Ø 6 | 1/8" | 10 |
| SAS2201FS-01-08C | Ø 8 | 1/8" | 10 |
| SAS2201FS-01-10C | Ø 10 | 1/8" | 10 |

Conico Teflonato
Taper: Teflon Coated

SAS TUBO TUBO - TUBE TO TUBE



| COD. | DIMENSIONI DEL TUBO <i>TUBE SIZE</i> | DIMENSIONI DEL CORPO <i>BODY SIZE</i> |  |
|----------------|---|--|---|
| SAS1002FS-03TT | Ø 3 | S | 10 |
| SAS1002FS-04TT | Ø 4 | S | 10 |
| SAS1002FS-05TT | Ø 5 | S | 10 |
| SAS1002FS-06TT | Ø 6 | S | 10 |
| SAS2002FS-04TT | Ø 4 | B | 10 |
| SAS2002FS-06TT | Ø 6 | B | 10 |

Conico Teflonato
Taper: Teflon Coated



PER VALVOLE - *FOR VALVES*

Valvola
Valve

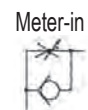

Simboli della direzione del flusso sul corpo
Flow direction symbols on body



PER CILINDRI - *FOR CYLINDERS*

Cilindro
Cylinder

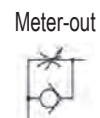

Simboli della direzione del flusso sul corpo
Flow direction symbols on body



TUBO TUBO - *TUBE TO TUBE*

Tubo Tubo
Tube to tube



Simboli della direzione del flusso sul corpo
Flow direction symbols on body

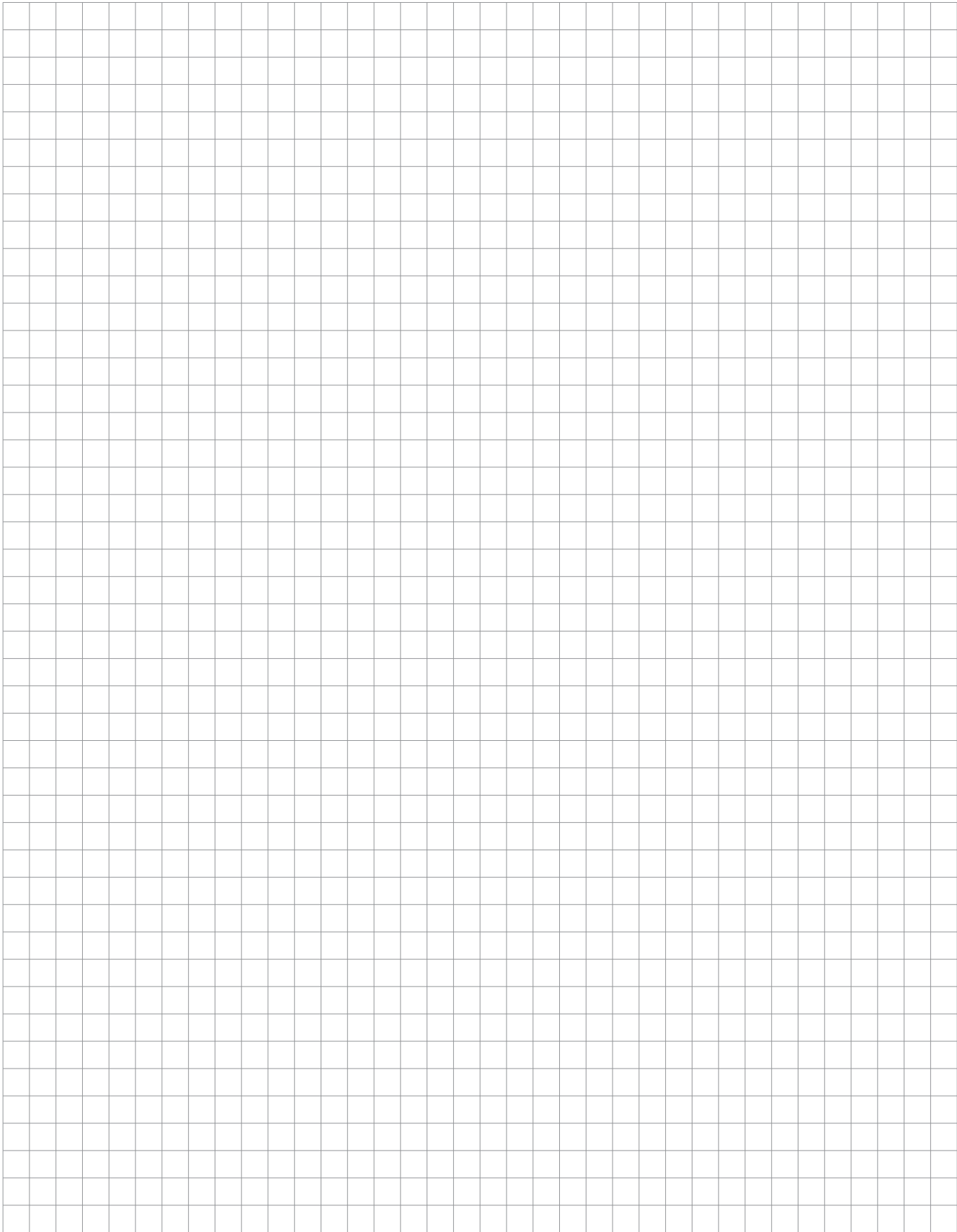

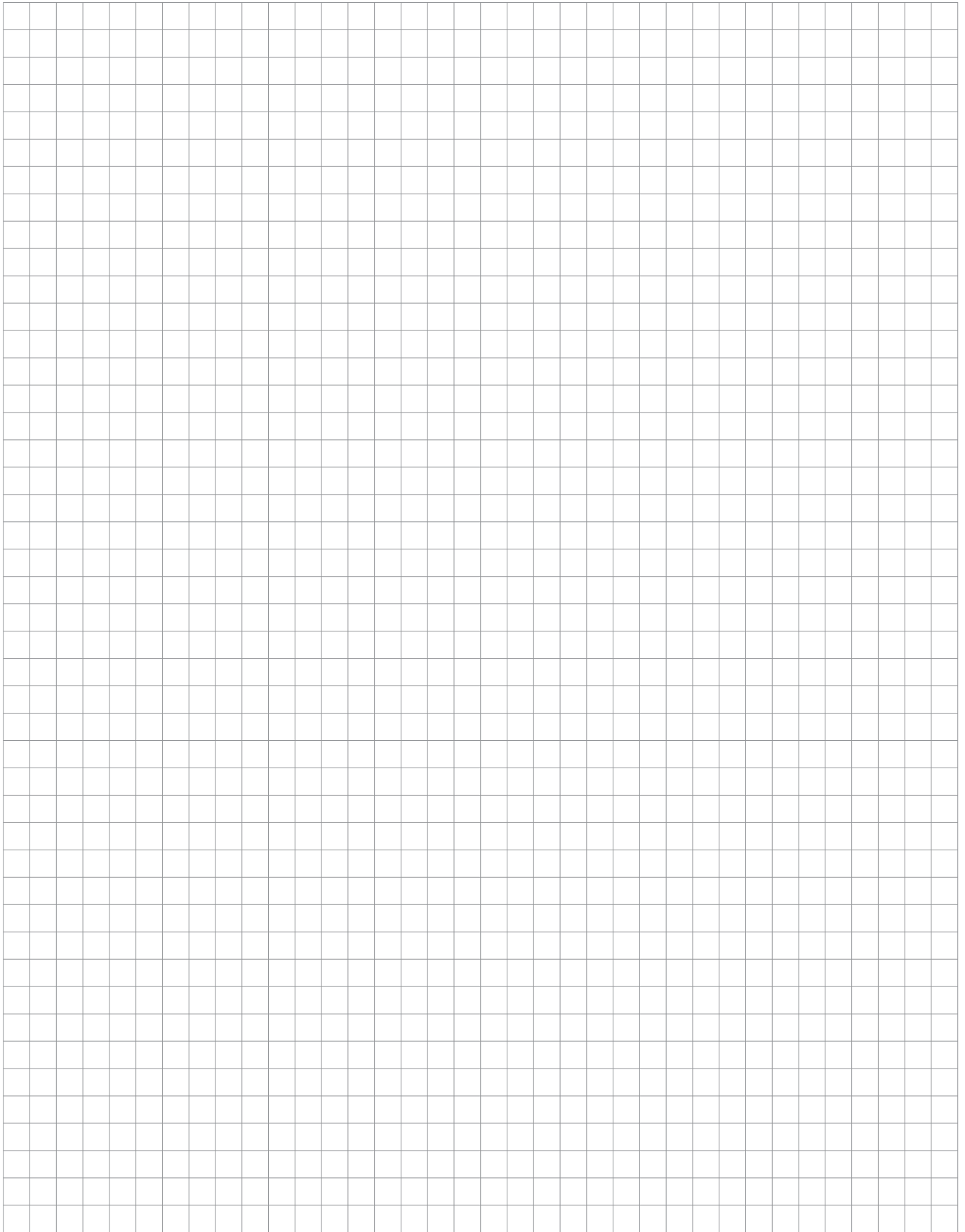



BRASS FITTINGS

RACCORDI STANDARD OTTONE - *STANDARD BRASS FITTINGS*

| | | | | | |
|---|-------|----|--|-------|----|
|  | RDM | 68 |  | PL | 69 |
|  | RDM-C | 68 |  | DB | 69 |
|  | RG | 68 |  | RMF | 69 |
|  | RG1-C | 68 |  | RMF-C | 69 |
|  | RG2 | 68 |  | PMF | 69 |
|  | RDF | 68 |  | PMF-C | 69 |
|  | RT | 68 |  | N | 70 |
|  | RT1-C | 68 |  | N-C | 70 |
|  | RT2-C | 68 |  | M | 70 |
|  | RX | 68 |  | RY FF | 70 |
|  | RP | 69 |  | RY MF | 70 |
|  | RPL | 69 |  | RG FF | 70 |

| | | | | | |
|---|----------|----|---|------|----|
|  | RG-C MM | 70 |  | VCDC | 71 |
|  | RG-C MF | 70 |  | VCTC | 71 |
|  | RDO | 70 |  | VCSL | 71 |
|  | RT FFF | 71 |  | VCDL | 71 |
|  | RT-C MMM | 71 |  | DNC | 72 |
|  | RT-C FMF | 71 |  | DNM | 72 |
|  | RT-C MFF | 71 |  | DNL | 72 |
|  | RT-C MFM | 71 |  | D | 72 |
|  | RT-C MMF | 71 |  | RS | 72 |
|  | RX 4F | 71 |  | RSE | 72 |
|  | RX-C M3F | 71 |  | T | 72 |
|  | AOL | 71 |  | T-C | 72 |
|  | VCSC | 71 |  | TF | 72 |

RACCORDI STANDARD OTTONE - STANDARD BRASS FITTINGS

| | | | | | |
|---|---------|----|--|---------|----|
|  | TB | 72 |  | R-RT1-G | 74 |
|  | TB-C | 72 |  | R-RT2-G | 74 |
|  | TZ | 72 |  | R-RT | 74 |
|  | P | 73 |  | R-GP | 74 |
|  | P-C | 73 |  | R-R | 75 |
|  | TR | 73 |  | R-AS | 75 |
|  | TP | 73 |  | R-AD | 75 |
|  | TPF | 73 |  | R-ASF-1 | 75 |
|  | R-RDM | 74 |  | R-ASF-2 | 75 |
|  | R-RG1-G | 74 |  | R-ASF-3 | 75 |
|  | R-G-C | 74 |  | R-AOS | 75 |
|  | R-RG | 74 |  | R-AOD | 75 |

| | | | | | |
|---|---------|----|---|----------|----|
|  | R-ADF-1 | 76 |  | WPUC | 78 |
|  | R-RDF | 76 |  | WPMM | 78 |
|  | R-AC | 76 |  | WPL-C | 78 |
|  | R-AL | 76 |  | WPL-G | 78 |
|  | R-TM | 76 |  | WPUL | 79 |
|  | R-TF | 76 |  | WPUT | 79 |
|  | R-RP | 76 |  | WPT | 79 |
|  | R-P | 76 |  | WPT-G | 79 |
|  | R-RL | 77 |  | WPST-C | 79 |
|  | DC | 77 |  | WPST-G | 79 |
|  | WPC-C | 78 |  | RH-RDM | 80 |
|  | WPC-G | 78 |  | RH-RG1-G | 80 |
|  | WPCF | 78 | | | |

RACCORDI STANDARD OTTONE - STANDARD BRASS FITTINGS

RDM



| COD | | 🛒 |
|-----------|----------------|----|
| 0.001 RDM | M5 - 5/3 | 25 |
| 0.002 RDM | M6 - 5/3 | 25 |
| 0.01 RDM | M5 - 6/4 | 25 |
| 0.02 RDM | M6 - 6/4 | 25 |
| 0.1 RDM | 1/8" - 5/3 | 25 |
| 1 RDM | 1/8" - 6/4 | 25 |
| 2 RDM | 1/8" - 8/6 | 25 |
| 3 RDM | 1/8" - 10/8 | 25 |
| 4 RDM | 1/4" - 6/4 | 25 |
| 5 RDM | 1/4" - 8/6 | 25 |
| 6 RDM | 1/4" - 10/8 | 25 |
| 7 RDM | 3/8" - 6/4 | 25 |
| 8 RDM | 3/8" - 8/6 | 25 |
| 9 RDM | 3/8" - 10/8 | 25 |
| 10 RDM | 3/8" - 12/10 | 25 |
| 11 RDM | 1/2" - 15/12,5 | 25 |

Cilindrico
Parallel

RDM-C



| COD | | 🛒 |
|-----------|-------------|----|
| 0.1 RDM-C | 1/8" - 5/3 | 25 |
| 1 RDM-C | 1/8" - 6/4 | 25 |
| 2 RDM-C | 1/8" - 8/6 | 25 |
| 3 RDM-C | 1/8" - 10/8 | 25 |
| 4 RDM-C | 1/4" - 6/4 | 25 |
| 5 RDM-C | 1/4" - 8/6 | 25 |
| 6 RDM-C | 1/4" - 10/8 | 25 |
| 7 RDM-C | 3/8" - 6/4 | 25 |
| 8 RDM-C | 3/8" - 8/6 | 25 |
| 9 RDM-C | 3/8" - 10/8 | 25 |

Conico
Taper

RG



| COD | | 🛒 |
|------|-----------|----|
| 1 RG | 5/3 | 25 |
| 2 RG | 6/4 | 25 |
| 3 RG | 8/6 - 6/4 | 25 |
| 4 RG | 8/6 | 25 |
| 5 RG | 10/8 | 25 |

RG1-C



| COD | | 🛒 |
|----------|--------------|----|
| 1 RG1-C | 1/8" - 5/3 | 25 |
| 2 RG1-C | 1/8" - 6/4 | 25 |
| 3 RG1-C | 1/8" - 8/6 | 25 |
| 4 RG1-C | 1/8" - 10/8 | 25 |
| 5 RG1-C | 1/4" - 6/4 | 25 |
| 6 RG1-C | 1/4" - 8/6 | 25 |
| 7 RG1-C | 1/4" - 10/8 | 25 |
| 8 RG1-C | 3/8" - 6/4 | 25 |
| 9 RG1-C | 3/8" - 8/6 | 25 |
| 10 RG1-C | 3/8" - 10/8 | 25 |
| 11 RG1-C | 3/8" - 12/10 | 25 |

Conico
Taper

RG2



| COD | | 🛒 |
|-------|-------------|----|
| 1 RG2 | 1/8" - 5/3 | 25 |
| 2 RG2 | 1/8" - 6/4 | 25 |
| 3 RG2 | 1/8" - 8/6 | 25 |
| 4 RG2 | 1/8" - 10/8 | 25 |
| 5 RG2 | 1/4" - 6/4 | 25 |
| 6 RG2 | 1/4" - 8/6 | 25 |
| 7 RG2 | 1/4" - 10/8 | 25 |

RDF



| COD | | 🛒 |
|-------|-------------|----|
| 1 RDF | 1/8" - 6/4 | 25 |
| 2 RDF | 1/8" - 8/6 | 25 |
| 3 RDF | 1/8" - 10/8 | 25 |
| 4 RDF | 1/4" - 6/4 | 25 |
| 5 RDF | 1/4" - 8/6 | 25 |
| 6 RDF | 1/4" - 10/8 | 25 |

RT



| COD | | 🛒 |
|------|------------|----|
| 1 RT | 5/3 | 25 |
| 2 RT | 6/4 | 25 |
| 3 RT | 8/6 - 6/4 | 25 |
| 4 RT | 8/6 | 25 |
| 5 RT | 10/8 - 6/4 | 25 |
| 6 RT | 10/8 - 8/6 | 25 |
| 7 RT | 10/8 | 25 |

RT1-C



| COD | | 🛒 |
|----------|-------------|----|
| 1 RT1-C | 1/8" - 5/3 | 25 |
| 2 RT1-C | 1/8" - 6/4 | 25 |
| 3 RT1-C | 1/8" - 8/6 | 25 |
| 4 RT1-C | 1/8" - 10/8 | 25 |
| 5 RT1-C | 1/4" - 6/4 | 25 |
| 6 RT1-C | 1/4" - 8/6 | 25 |
| 7 RT1-C | 1/4" - 10/8 | 25 |
| 8 RT1-C | 3/8" - 6/4 | 25 |
| 9 RT1-C | 3/8" - 8/6 | 25 |
| 10 RT1-C | 3/8" - 10/8 | 25 |

Conico
Taper

RT2-C



| COD | | 🛒 |
|----------|-------------|----|
| 1 RT2-C | 1/8" - 5/3 | 25 |
| 2 RT2-C | 1/8" - 6/4 | 25 |
| 3 RT2-C | 1/8" - 8/6 | 25 |
| 4 RT2-C | 1/8" - 10/8 | 25 |
| 5 RT2-C | 1/4" - 6/4 | 25 |
| 6 RT2-C | 1/4" - 8/6 | 25 |
| 7 RT2-C | 1/4" - 10/8 | 25 |
| 8 RT2-C | 3/8" - 6/4 | 25 |
| 9 RT2-C | 3/8" - 8/6 | 25 |
| 10 RT2-C | 3/8" - 10/8 | 25 |

Conico
Taper

RX



| COD | | 🛒 |
|------|------|----|
| 1 RX | 5/3 | 25 |
| 2 RX | 6/4 | 25 |
| 3 RX | 8/6 | 25 |
| 4 RX | 10/8 | 25 |

RP



| COD | | 🛒 |
|------|------------|----|
| 1 RP | 5/3 | 25 |
| 2 RP | 6/4 | 25 |
| 3 RP | 8/6 - 6/4 | 25 |
| 4 RP | 8/6 | 25 |
| 5 RP | 10/8 - 6/4 | 25 |
| 6 RP | 10/8 - 8/6 | 25 |
| 7 RP | 10/8 | 25 |

RPL



| COD | | 🛒 |
|-------|------------|----|
| 1 RPL | 5/3 | 25 |
| 2 RPL | 6/4 | 25 |
| 3 RPL | 8/6 - 6/4 | 25 |
| 4 RPL | 8/6 | 25 |
| 5 RPL | 10/8 | 25 |
| 6 RPL | 10/8 - 6/4 | 25 |

PL



| COD | | 🛒 |
|--------|------------|----|
| 1 PL | 1/8" L. 22 | 25 |
| 2 PL | 1/8" L. 23 | 25 |
| 2.1 PL | 1/8" L. 32 | 25 |
| 3 PL | 1/8" L. 42 | 25 |
| 4 PL | 1/8" L. 44 | 25 |
| 5 PL | 1/4 L. 28 | 25 |
| 6 PL | 1/4" L. 35 | 25 |
| 7 PL | 1/4" L. 45 | 25 |
| 8 PL | 1/4" L. 51 | 25 |
| 9 PL | 3/8" L. 41 | 25 |
| 10 PL | 1/2" L. 36 | 25 |
| 11 PL | 3/4" L. 50 | 25 |
| 12 PL | 1" L. 50 | 25 |

Cilindrico
Parallel

DB



| COD | | 🛒 |
|------|------|----|
| 1 DB | 5/3 | 25 |
| 2 DB | 6/4 | 25 |
| 3 DB | 8/6 | 25 |
| 4 DB | 10/8 | 25 |

RMF



| COD | | |
|---------|-----------------|----|
| 1 RMF | 1/8" - M5 | 25 |
| 2 RMF | 1/4" - 1/8 | 25 |
| 3 RMF | 3/8" - 1/8" | 25 |
| 4 RMF | 3/8" - 1/4" | 25 |
| 4.1 RMF | 1/2" - 1/8" | 25 |
| 5 RMF | 1/2" - 1/4" | 25 |
| 6 RMF | 1/2" - 3/8" | 25 |
| 7 RMF | 3/4" - 1/4" | 25 |
| 8 RMF | 3/4" - 3/8" | 25 |
| 9 RMF | 3/4" - 1/2" | 25 |
| 10 RMF | 1" - 3/8" | 25 |
| 11 RMF | 1" - 1/2" | 25 |
| 12 RMF | 1" - 3/4" | 25 |
| 13 RMF | 1" 1/4 - 1" | 5 |
| 15 RMF | 1" 1/2 - 1" 1/4 | 5 |
| 17 RMF | 2" - 1" 1/4 | 5 |
| 18 RMF | 2" - 1" 1/2 | 5 |

Cilindrico
Parallel

RMF-C



| COD | | 🛒 |
|-----------|-----------------|----|
| 1 RMF-C | 1/4" - 1/8" | 25 |
| 2 RMF-C | 3/8" - 1/8" | 25 |
| 3 RMF-C | 3/8" - 1/4" | 25 |
| 3.1 RMF-C | 1/2" - 1/8" | 25 |
| 4 RMF-C | 1/2" - 1/4" | 25 |
| 5 RMF-C | 1/2" - 3/8" | 25 |
| 6 RMF-C | 3/4" - 1/4" | 25 |
| 7 RMF-C | 3/4" - 3/8" | 25 |
| 8 RMF-C | 3/4" - 1/2" | 25 |
| 9 RMF-C | 1" - 3/8" | 25 |
| 9.1 RMF-C | 1" - 1/4" | 25 |
| 10 RMF-C | 1" - 1/2 | 25 |
| 11 RMF-C | 1" - 3/4" | 25 |
| 12 RMF-C | 1" 1/4 - 1" | 5 |
| 13 RMF-C | 1" 1/2 - 1" | 5 |
| 14 RMF-C | 1" 1/2 - 1" 1/4 | 5 |
| 16 RMF-C | 2" - 1" 1/4 | 5 |
| 17 RMF-C | 2" - 1" 1/2 | 5 |

Conico
Taper

PMF



| COD | | 🛒 |
|--------|-------------|----|
| 1 PMF | M5 - M5 | 25 |
| 2 PMF | M5 - 1/8 | 25 |
| 3 PMF | 1/8" - 1/8" | 25 |
| 4 PMF | 1/8" - 1/4" | 25 |
| 5 PMF | 1/8" - 3/8" | 25 |
| 6 PMF | 1/4" - 1/4" | 25 |
| 7 PMF | 1/4" - 3/8" | 25 |
| 8 PMF | 1/4" - 1/2" | 25 |
| 9 PMF | 3/8" - 3/8" | 25 |
| 10 PMF | 3/8" - 1/2" | 25 |
| 11 PMF | 1/2" - 1/2" | 25 |
| 12 PMF | 3/8" - 3/4" | 25 |
| 13 PMF | 1/2" - 3/4" | 25 |
| 14 PMF | 3/4" - 3/4" | 25 |
| 15 PMF | 1/2" - 1" | 25 |
| 16 PMF | 3/4" - 1" | 25 |
| 17 PMF | 1" - 1" | 25 |

Cilindrico
Parallel

PMF-C



| COD | | 🛒 |
|----------|-------------|----|
| 1 PMF-C | 1/8" - 1/8" | 25 |
| 2 PMF-C | 1/8" - 1/4" | 25 |
| 3 PMF-C | 1/8" - 3/8" | 25 |
| 4 PMF-C | 1/4" - 1/4" | 25 |
| 5 PMF-C | 1/4" - 3/8" | 25 |
| 6 PMF-C | 1/4" - 1/2" | 25 |
| 7 PMF-C | 3/8" - 3/8" | 25 |
| 8 PMF-C | 3/8" - 1/2" | 25 |
| 9 PMF-C | 1/2" - 1/2" | 25 |
| 10 PMF-C | 3/8" - 3/4" | 25 |
| 11 PMF-C | 1/2" - 3/4" | 25 |
| 12 PMF-C | 3/4" - 3/4" | 25 |
| 13 PMF-C | 1/2" - 1" | 25 |
| 14 PMF-C | 3/4" - 1" | 25 |
| 15 PMF-C | 1" - 1" | 25 |

Conico
Taper

RACCORDI STANDARD OTTONE - STANDARD BRASS FITTINGS



Cilindrico - *Parallel*

| N | | |
|--------|-----------------|----|
| COD | | 🛒 |
| 1 N | M5 - M5 | 25 |
| 2 N | M5 - 1/8" | 25 |
| 3 N | 1/8" - 1/8" | 25 |
| 4 N | 1/8" - 1/4" | 25 |
| 5 N | 1/8" - 3/8" | 25 |
| 6 N | 1/4" - 1/4" | 25 |
| 7 N | 1/4" - 3/8" | 25 |
| 8 N | 1/4" - 1/2" | 25 |
| 9 N | 3/8" - 3/8" | 25 |
| 10 N | 3/8" - 1/2" | 25 |
| 10.1 N | 3/8" - 3/4" | 25 |
| 11 N | 1/2" - 1/2" | 25 |
| 12 N | 1/2" - 3/4" | 25 |
| 13 N | 3/4" - 3/4" | 25 |
| 14 N | 3/4" - 1" | 25 |
| 15 N | 1" - 1" | 25 |
| 16 N | 1" 1/4 - 1" | 5 |
| 16 N * | 1" 1/4 - 1" | 5 |
| 17 N | 1" 1/4 - 1" 1/4 | 5 |
| 17 N * | 1" 1/4 - 1" 1/4 | 5 |
| 18 N | 1" 1/2 - 1" 1/4 | 5 |
| 18 N * | 1" 1/2 - 1" 1/4 | 5 |
| 19 N | 1" 1/2 - 1" 1/2 | 5 |
| 19 N * | 1" 1/2 - 1" 1/2 | 5 |
| 20 N | 2" - 1" 1/2 | 5 |
| 20 N * | 2" - 1" 1/2 | 5 |
| 21 N | 2" - 2" | 5 |
| 21 N * | 2" - 2" | 5 |

I codici con * si riferiscono al tipo "light".
codes with * are for "light" type.



Conico - *Taper*

| N-C | | |
|---------|-----------------|----|
| COD | | 🛒 |
| 1 N-C | 1/8" - 1/8" | 25 |
| 2 N-C | 1/8" - 1/4" | 25 |
| 3 N-C | 1/8" - 3/8" | 25 |
| 4 N-C | 1/4" - 1/4" | 25 |
| 5 N-C | 1/4" - 3/8" | 25 |
| 6 N-C | 1/4" - 1/2" | 25 |
| 7 N-C | 3/8" - 3/8" | 25 |
| 8 N-C | 3/8" - 1/2" | 25 |
| 9 N-C | 1/2" - 1/2" | 25 |
| 10 N-C | 1/2" - 3/4" | 25 |
| 11 N-C | 3/4" - 3/4" | 25 |
| 12 N-C | 3/4" - 1" | 25 |
| 13 N-C | 1" - 1" | 25 |
| 14 N-C | 1" 1/4 - 1" | 5 |
| 14 N-C* | 1" 1/4 - 1" | 5 |
| 15 N-C | 1" 1/4 - 1" 1/4 | 5 |
| 15 N-C* | 1" 1/4 - 1" 1/4 | 5 |
| 16 N-C | 1" 1/2 - 1" 1/4 | 5 |
| 16 N-C* | 1" 1/2 - 1" 1/4 | 5 |
| 17 N-C | 1" 1/2 - 1" 1/2 | 5 |
| 17 N-C* | 1" 1/2 - 1" 1/2 | 5 |
| 18 N-C | 2" - 1" 1/2 | 5 |
| 18 N-C* | 2" - 1" 1/2 | 5 |
| 19 N-C | 2" - 2" | 5 |
| 19 N-C* | 2" - 2" | 5 |

I codici con * si riferiscono al tipo "light".
codes with * are for "light" type.



| M | | |
|--------|-------------|----|
| COD | | 🛒 |
| 1 M | M5 - M5 | 25 |
| 2 M | M5 - 1/8" | 25 |
| 3 M | 1/8" - 1/8" | 25 |
| 4 M | 1/8" - 1/4" | 25 |
| 5 M | 1/8" - 3/8" | 25 |
| 6 M | 1/4" - 1/4" | 25 |
| 7 M | 1/4" - 3/8" | 25 |
| 8 M | 1/4" - 1/2" | 25 |
| 9 M | 3/8" - 3/8" | 25 |
| 10 M | 3/8" - 1/2" | 25 |
| 10.1 M | 3/8" - 3/4" | 25 |
| 11 M | 1/2" - 1/2" | 25 |
| 12 M | 1/2" - 3/4" | 25 |
| 12.1 M | 1/2" - 1" | 25 |
| 13 M | 3/4" - 3/4" | 25 |
| 14 M | 3/4" - 1" | 25 |
| 15 M | 1" - 1" | 25 |



| RY FF | | |
|---------|------|----|
| COD | | 🛒 |
| 1 RY FF | 1/8" | 25 |
| 2 RY FF | 1/4" | 25 |
| 3 RY FF | 3/8" | 25 |
| 4 RY FF | 1/2" | 25 |



Cilindrico - *Parallel*

| RY MF | | |
|---------|------|----|
| COD | | 🛒 |
| 1 RY MF | 1/8" | 25 |
| 2 RY MF | 1/4" | 25 |
| 3 RY MF | 3/8" | 25 |
| 4 RY MF | 1/2" | 25 |



| RG FF | | |
|---------|------|----|
| COD | | 🛒 |
| 1 RG FF | M5 | 25 |
| 2 RG FF | 1/8" | 25 |
| 3 RG FF | 1/4" | 25 |
| 4 RG FF | 3/8" | 25 |
| 5 RG FF | 1/2" | 25 |
| 6 RG FF | 3/4" | 25 |
| 7 RG FF | 1" | 25 |



Conico - *Taper*

| RG-C MM | | |
|-----------|------|----|
| COD | | 🛒 |
| 1 RG MM | M5 | 25 |
| 2 RG-C MM | 1/8" | 25 |
| 3 RG-C MM | 1/4" | 25 |
| 4 RG-C MM | 3/8" | 25 |
| 5 RG-C MM | 1/2" | 25 |
| 6 RG-C MM | 3/4" | 25 |
| 7 RG-C MM | 1" | 25 |



Conico - *Taper*

| RG-C MF | | |
|-----------|------|----|
| COD | | 🛒 |
| 1 RG MF | M5 | 25 |
| 2 RG-C MF | 1/8" | 25 |
| 3 RG-C MF | 1/4" | 25 |
| 4 RG-C MF | 3/8" | 25 |
| 5 RG-C MF | 1/2" | 25 |
| 6 RG-C MF | 3/4" | 25 |
| 7 RG-C MF | 1" | 25 |



Cilindrico - Con ogiva
Parallel - With ogive

| RDO | | |
|-------|------------|----|
| COD | | 🛒 |
| 1 RDO | 1/8" - 4/2 | 25 |
| 2 RDO | 1/8" - 6/4 | 25 |
| 3 RDO | 1/8" - 8/6 | 25 |
| 4 RDO | 1/4" - 6/4 | 25 |
| 5 RDO | 1/4" - 8/6 | 25 |



| RT FFF | | | |
|----------|------|----|---|
| COD | | | 🛒 |
| 1 RT FFF | M5 | 25 | |
| 2 RT FFF | 1/8" | 25 | |
| 3 RT FFF | 1/4" | 25 | |
| 4 RT FFF | 3/8" | 25 | |
| 5 RT FFF | 1/2" | 25 | |
| 6 RT FFF | 3/4" | 25 | |
| 7 RT FFF | 1" | 25 | |



| RT-C MMM | | | |
|------------|------|----|---|
| COD | | | 🛒 |
| 1 RT MMM | M5 | 25 | |
| 2 RT-C MMM | 1/8" | 25 | |
| 3 RT-C MMM | 1/4" | 25 | |
| 4 RT-C MMM | 3/8" | 25 | |
| 5 RT-C MMM | 1/2" | 25 | |
| 6 RT-C MMM | 3/4" | 25 | |
| 7 RT-C MMM | 1" | 25 | |

Conico - Taper



| RT-C FMF | | | |
|------------|------|----|---|
| COD | | | 🛒 |
| 1 RT FMF | M5 | 25 | |
| 2 RT-C FMF | 1/8" | 25 | |
| 3 RT-C FMF | 1/4" | 25 | |
| 4 RT-C FMF | 3/8" | 25 | |
| 5 RT-C FMF | 1/2" | 25 | |
| 6 RT-C FMF | 3/4" | 25 | |
| 7 RT-C FMF | 1" | 25 | |

Conico - Taper



| RT-C MFF | | | |
|------------|------|----|---|
| COD | | | 🛒 |
| 1 RT MFF | M5 | 25 | |
| 2 RT-C MFF | 1/8" | 25 | |
| 3 RT-C MFF | 1/4" | 25 | |
| 4 RT-C MFF | 3/8" | 25 | |
| 5 RT-C MFF | 1/2" | 25 | |
| 6 RT-C MFF | 3/4" | 25 | |
| 7 RT-C MFF | 1" | 25 | |

Conico - Taper



| RT-C MFM | | | |
|------------|------|----|---|
| COD | | | 🛒 |
| 1 RT MFM | M5 | 25 | |
| 2 RT-C MFM | 1/8" | 25 | |
| 3 RT-C MFM | 1/4" | 25 | |
| 4 RT-C MFM | 3/8" | 25 | |
| 5 RT-C MFM | 1/2" | 25 | |
| 6 RT-C MFM | 3/4" | 25 | |
| 7 RT-C MFM | 1" | 25 | |

Conico - Taper



| RT-C MMF | | | |
|------------|------|----|---|
| COD | | | 🛒 |
| 1 RT MMF | M5 | 25 | |
| 2 RT-C MMF | 1/8" | 25 | |
| 3 RT-C MMF | 1/4" | 25 | |
| 4 RT-C MMF | 3/8" | 25 | |
| 5 RT-C MMF | 1/2" | 25 | |
| 6 RT-C MMF | 3/4" | 25 | |
| 7 RT-C MMF | 1" | 25 | |

Conico - Taper



| RX 4F | | | |
|---------|------|----|---|
| COD | | | 🛒 |
| 2 RX 4F | 1/8" | 25 | |
| 3 RX 4F | 1/4" | 25 | |
| 4 RX 4F | 3/8" | 25 | |
| 5 RX 4F | 1/2" | 25 | |



| RX-C M3F | | | |
|------------|------|----|---|
| COD | | | 🛒 |
| 2 RX-C M3F | 1/8" | 25 | |
| 3 RX-C M3F | 1/4" | 25 | |
| 4 RX-C M3F | 3/8" | 25 | |
| 5 RX-C M3F | 1/2" | 25 | |

Conico - Taper



| AOL | | | |
|-------|-------------|----|---|
| COD | | | 🛒 |
| 1 AOL | 1/8" - 5/3 | 25 | |
| 2 AOL | 1/8" - 6/4 | 25 | |
| 3 AOL | 1/8" - 8/6 | 25 | |
| 4 AOL | 1/4" - 6/4 | 25 | |
| 5 AOL | 1/4" - 8/6 | 25 | |
| 6 AOL | 1/4" - 10/8 | 25 | |



| VCSC | | | |
|--------|------|----|---|
| COD | | | 🛒 |
| 1 VCSC | 1/8" | 25 | |
| 2 VCSC | 1/4" | 25 | |

Cilindrico - Parallel



| VCDC | | | |
|--------|------|----|---|
| COD | | | 🛒 |
| 1 VCDC | 1/8" | 25 | |
| 2 VCDC | 1/4" | 25 | |

Cilindrico - Parallel



| VCTC | | | |
|--------|------|----|---|
| COD | | | 🛒 |
| 1 VCTC | 1/8" | 25 | |
| 2 VCTC | 1/4" | 25 | |

Cilindrico - Parallel



| VCSL | | | |
|--------|------|----|---|
| COD | | | 🛒 |
| 1 VCSL | 1/8" | 25 | |
| 2 VCSL | 1/4" | 25 | |

Cilindrico - Parallel



| VCDL | | | |
|--------|------|----|---|
| COD | | | 🛒 |
| 1 VCDL | 1/8" | 25 | |
| 2 VCDL | 1/4" | 25 | |

Cilindrico - Parallel

RACCORDI STANDARD OTTONE - STANDARD BRASS FITTINGS

DNC



| COD | | 🛒 |
|-------|------|----|
| 1 DNC | 1/8" | 25 |
| 2 DNC | 1/4" | 25 |

Distanziale - Nylon
Spacer - Nylon

DNM



| COD | | 🛒 |
|-------|------|----|
| 1 DNM | 1/8" | 25 |
| 2 DNM | 1/4" | 25 |

Distanziale - Nylon
Spacer - Nylon

DNL



| COD | | 🛒 |
|-------|------|----|
| 1 DNL | 1/8" | 25 |
| 2 DNL | 1/4" | 25 |

Distanziale - Nylon
Spacer - Nylon

D



| COD | | 🛒 |
|-----|------|----|
| 1 D | 1/8" | 25 |
| 2 D | 1/4" | 25 |
| 3 D | 3/8" | 25 |
| 4 D | 1/2" | 25 |
| 5 D | 3/4" | 25 |
| 6 D | 1" | 25 |
| 7 D | M5 | 25 |

RS

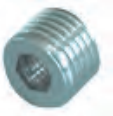

| COD | | 🛒 |
|--------|-------------|----|
| 1-7 RS | 1/8" - M5 | 25 |
| 2-1 RS | 1/4" - 1/8" | 25 |
| 3-1 RS | 3/8" - 1/8" | 25 |
| 3-2 RS | 3/8" - 1/4" | 25 |
| 4-2 RS | 1/2" - 1/4" | 25 |
| 4-3 RS | 1/2" - 3/8" | 25 |
| 5-4 RS | 3/4" - 1/2" | 25 |
| 6-5 RS | 1" - 3/4" | 25 |

Cilindrico - *Parallel*

RSE



| COD | | 🛒 |
|----------|-------------|----|
| 1-7 RSE | 1/8" - M5 | 25 |
| 2-1 RSE | 1/4" - 1/8" | 25 |
| 3-1 RSE | 3/8" - 1/8" | 25 |
| 3-2 RSE | 3/8" - 1/4" | 25 |
| 4-2 RSE | 1/2" - 1/4" | 25 |
| 4-3 RSE | 1/2" - 3/8" | 25 |
| 5-4 RSE | 3/4" - 1/2" | 25 |
| 6-5 RSE | 1" - 3/4" | 25 |
| 11-6 RSE | 1" 1/4 - 1" | 25 |

Cilindrico - *Parallel*

T



| COD | | 🛒 |
|-----|------|----|
| 1 T | 1/8" | 25 |
| 2 T | 1/4" | 25 |
| 3 T | 3/8" | 25 |
| 4 T | 1/2" | 25 |
| 5 T | 3/4" | 25 |
| 6 T | 1" | 25 |
| 7 T | M5 | 25 |

Cilindrico - *Parallel*

T-C



| COD | | 🛒 |
|-------|------|----|
| 1 T-C | 1/8" | 25 |
| 2 T-C | 1/4" | 25 |
| 3 T-C | 3/8" | 25 |
| 4 T-C | 1/2" | 25 |
| 5 T-C | 3/4" | 25 |
| 6 TC | 1" | 25 |

Conico - *Taper*

TF



| COD | | 🛒 |
|------|------|----|
| 1 TF | 1/8" | 25 |
| 2 TF | 1/4" | 25 |
| 3 TF | 3/8" | 25 |
| 4 TF | 1/2" | 25 |
| 5 TF | 3/4" | 25 |
| 6 TF | 1" | 25 |
| 7 TF | M5 | 25 |

Femmina - *Female*

TB



| COD | | 🛒 |
|------|------|----|
| 1 TB | 1/8" | 25 |
| 2 TB | 1/4" | 25 |
| 3 TB | 3/8" | 25 |
| 4 TB | 1/2" | 25 |

Cilindrico - *Parallel*

TB-C



| COD | | 🛒 |
|--------|------|----|
| 1 TB-C | 1/8" | 25 |
| 2 TB-C | 1/4" | 25 |
| 3 TB-C | 3/8" | 25 |
| 4 TB-C | 1/2" | 25 |
| 5 TB-C | 3/4" | 25 |
| 6 TB-C | 1" | 25 |

Conico - *Taper*

TZ



| COD | | 🛒 |
|------|------|----|
| 1 TZ | 1/8" | 25 |
| 2 TZ | 1/4" | 25 |
| 3 TZ | 3/8" | 25 |
| 4 TZ | 1/2" | 25 |
| 5 TZ | 3/4" | 25 |
| 7 TZ | M5 | 25 |

Cilindrico + OR
Parallel + OR



| P | | | |
|-----|----------------|----|---|
| COD | | |  |
| 1 P | 1/8" tubo-tube | 6 | 25 |
| 1 P | 1/8" tubo-tube | 7 | 25 |
| 1 P | 1/8" tubo-tube | 8 | 25 |
| 1 P | 1/8" tubo-tube | 9 | 25 |
| 1 P | 1/8" tubo-tube | 12 | 25 |
| 2 P | 1/4" tubo-tube | 7 | 25 |
| 2 P | 1/4" tubo-tube | 8 | 25 |
| 2 P | 1/4" tubo-tube | 9 | 25 |
| 2 P | 1/4" tubo-tube | 12 | 25 |
| 3 P | 3/8" tubo-tube | 9 | 25 |
| 3 P | 3/8" tubo-tube | 10 | 25 |
| 3 P | 3/8" tubo-tube | 12 | 25 |
| 3 P | 3/8" tubo-tube | 17 | 25 |
| 4 P | 1/2" tubo-tube | 12 | 25 |
| 4 P | 1/2" tubo-tube | 17 | 25 |
| 4 P | 1/2" tubo-tube | 20 | 25 |
| 7 P | M5 tubo-tube | 6 | 25 |
| 7 P | M5 tubo-tube | 7 | 25 |
| 8 P | M6 tubo-tube | 6 | 25 |
| 8 P | M6 tubo-tube | 7 | 25 |

Cilindrico
Parallel



| P-C | | | |
|-------|----------------|----|---|
| COD | | |  |
| 1 P-C | 1/8" tubo-tube | 10 | 25 |
| 1 P-C | 1/8" tubo-tube | 6 | 25 |
| 1 P-C | 1/8" tubo-tube | 7 | 25 |
| 1 P-C | 1/8" tubo-tube | 8 | 25 |
| 1 P-C | 1/8" tubo-tube | 9 | 25 |
| 2 P-C | 1/4" tubo-tube | 10 | 25 |
| 2 P-C | 1/4" tubo-tube | 12 | 25 |
| 2 P-C | 1/4" tubo-tube | 6 | 25 |
| 2 P-C | 1/4" tubo-tube | 7 | 25 |
| 2 P-C | 1/4" tubo-tube | 8 | 25 |
| 2 P-C | 1/4" tubo-tube | 9 | 25 |
| 3 P-C | 3/8" tubo-tube | 10 | 25 |
| 3 P-C | 3/8" tubo-tube | 12 | 25 |
| 3 P-C | 3/8" tubo-tube | 14 | 25 |
| 3 P-C | 3/8" tubo-tube | 16 | 25 |
| 3 P-C | 3/8" tubo-tube | 17 | 25 |
| 3 P-C | 3/8" tubo-tube | 18 | 25 |
| 3 P-C | 3/8" tubo-tube | 20 | 25 |
| 4 P-C | 1/2" tubo-tube | 10 | 25 |
| 4 P-C | 1/2" tubo-tube | 12 | 25 |
| 4 P-C | 1/2" tubo-tube | 16 | 25 |
| 4 P-C | 1/2" tubo-tube | 17 | 25 |
| 4 P-C | 1/2" tubo-tube | 18 | 25 |
| 4 P-C | 1/2" tubo-tube | 20 | 25 |
| 5 P-C | 3/4" tubo-tube | 16 | 25 |
| 5 P-C | 3/4" tubo-tube | 18 | 25 |
| 5 P-C | 3/4" tubo-tube | 20 | 25 |
| 5 P-C | 3/4" tubo-tube | 25 | 25 |
| 6 P-C | 1" tubo-tube | 25 | 25 |

Conico
Taper



| TR | | | |
|-------|------|--|---|
| COD | | |  |
| 10 TR | Ø 4 | | 25 |
| 20 TR | Ø 5 | | 25 |
| 30 TR | Ø 6 | | 25 |
| 40 TR | Ø 8 | | 25 |
| 50 TR | Ø 10 | | 25 |
| 60 TR | Ø 12 | | 25 |
| 70 TR | Ø 14 | | 25 |

Tubo in Rilsan
Rilsan tube



| TP | | | |
|------|------|--|---|
| COD | | |  |
| 1 TP | 1/8" | | 25 |
| 2 TP | 1/4" | | 25 |
| 3 TP | 3/8" | | 25 |
| 4 TP | 1/2" | | 25 |
| 5 TP | 3/4" | | 25 |
| 6 TP | 1" | | 25 |

Maschio - Materiale: PA6
Male - Material: PA6



| TPF | | | |
|-------|------|--|---|
| COD | | |  |
| 1 TPF | 1/8" | | 25 |
| 2 TPF | 1/4" | | 25 |
| 3 TPF | 3/8" | | 25 |
| 4 TPF | 1/2" | | 25 |
| 5 TPF | 3/4" | | 25 |
| 6 TPF | 1" | | 25 |

Femmina - Materiale: PA6
Female - Material: PA6

| MATERIALI UTILIZZATI - <i>MATERIALS</i> | | | |
|---|--------------------------------|---------------------------|-----------------------------|
| OTTONE | OT58 | BRASS | OT58 |
| BRONZO | | BRONZE | |
| INOX | AISI 302-AISI 304 | STAINLESS STEEL | AISI 302-AISI 304 |
| | AISI 316-AISI 316L | | AISI 316-AISI 316L |
| RAME | CU | COPPER | CU |
| ACCIAIO | AVP | STEEL | AVP |
| | FEP13 | | FEP13 |
| ALLUMINIO | AL AG3 | ALUMINIUM | AL AG3 |
| PA6 | | PA6 | |
| PVC | | PVC | |
| PLASTICA POROSA | PEHD | POROUS PLASTIC | PEHD |
| RESINA ACETALICA | | ACETAL RESIN | |
| TECNOPLIMERO | NYLON 6.6 + 50% FIBRA DI VETRO | POLYMER | NYLON 6.6 + 50% GLASS FIBER |
| GUARNIZIONI | NBR | SEALS | NBR |
| | VITON | | VITON |
| | POLIURETANO | | POLYURETHANE |
| | NEOPRENE | | NEOPRENE |
| | FIBRA CELLULOSICA | | CELLULOSIC FIBER |
| POLVERE EPOSSIDICA PER VERNICIATURA | | EPOXY POWDER FOR PAINTING | |

RACCORDI RAPIDI STANDARD OTTONE - PUSH-IN BRASS FITTINGS



R-RDM

| COD | | | | 🛒 |
|----------|----|------|----|---|
| 1 R-RDM | 4 | M5 | 25 | |
| 2 R-RDM | 4 | M7 | 25 | |
| 3 R-RDM | 4 | 1/8" | 25 | |
| 4 R-RDM | 4 | 1/4" | 25 | |
| 5 R-RDM | 4 | M6 | 25 | |
| 6 R-RDM | 5 | M5 | 25 | |
| 7 R-RDM | 5 | 1/8" | 25 | |
| 8 R-RDM | 5 | 1/4" | 25 | |
| 9 R-RDM | 6 | M5 | 25 | |
| 10 R-RDM | 6 | M7 | 25 | |
| 11 R-RDM | 6 | 1/8" | 25 | |
| 12 R-RDM | 6 | 1/4" | 25 | |
| 13 R-RDM | 6 | 3/8" | 25 | |
| 14 R-RDM | 8 | 1/8" | 25 | |
| 15 R-RDM | 8 | 1/4" | 25 | |
| 16 R-RDM | 8 | 3/8" | 25 | |
| 17 R-RDM | 10 | 1/4" | 25 | |
| 18 R-RDM | 10 | 3/8" | 25 | |
| 19 R-RDM | 10 | 1/2" | 25 | |
| 20 R-RDM | 12 | 1/4" | 25 | |
| 21 R-RDM | 12 | 3/8" | 25 | |
| 22 R-RDM | 12 | 1/2" | 25 | |
| 23 R-RDM | 14 | 3/8" | 25 | |
| 24 R-RDM | 14 | 1/2" | 25 | |

Cilindrico + OR
Parallel + OR



R-RG1-G

| COD | | | | 🛒 |
|------------|----|------|----|---|
| 1 R-RG1-G | 4 | M5 | 25 | |
| 2 R-RG1-G | 4 | M6 | 25 | |
| 3 R-RG1-G | 4 | M7 | 25 | |
| 4 R-RG1-G | 4 | 1/8" | 25 | |
| 5 R-RG1-G | 4 | 1/4" | 25 | |
| 6 R-RG1-G | 6 | M5 | 25 | |
| 7 R-RG1-G | 6 | M6 | 25 | |
| 8 R-RG1-G | 6 | M7 | 25 | |
| 9 R-RG1-G | 6 | 1/8" | 25 | |
| 10 R-RG1-G | 6 | 1/4" | 25 | |
| 11 R-RG1-G | 6 | 3/8" | 25 | |
| 12 R-RG1-G | 8 | 1/8" | 25 | |
| 13 R-RG1-G | 8 | 1/4" | 25 | |
| 14 R-RG1-G | 8 | 3/8" | 25 | |
| 15 R-RG1-G | 10 | 1/8" | 25 | |
| 16 R-RG1-G | 10 | 1/4" | 25 | |
| 17 R-RG1-G | 10 | 3/8" | 25 | |
| 18 R-RG1-G | 10 | 1/2" | 25 | |
| 19 R-RG1-G | 12 | 1/4" | 25 | |
| 20 R-RG1-G | 12 | 3/8" | 25 | |
| 21 R-RG1-G | 12 | 1/2" | 25 | |
| 22 R-RG1-G | 14 | 3/8" | 25 | |
| 23 R-RG1-G | 14 | 1/2" | 25 | |

Cilindrico + OR
Parallel + OR



R-G-C

| COD | | | | 🛒 |
|---------|---|------|----|---|
| 1 R-G-C | 4 | 1/8" | 25 | |
| 2 R-G-C | 6 | 1/8" | 25 | |
| 3 R-G-C | 8 | 1/8" | 25 | |
| 4 R-G-C | 8 | 1/4" | 25 | |

Conico-Taper



R-RG

| COD | | | | 🛒 |
|--------|----|--|----|---|
| 1 R-RG | 4 | | 25 | |
| 2 R-RG | 5 | | 25 | |
| 3 R-RG | 6 | | 25 | |
| 4 R-RG | 8 | | 25 | |
| 5 R-RG | 10 | | 25 | |
| 6 R-RG | 12 | | 25 | |
| 7 R-RG | 14 | | 25 | |



R-RT1-G

| COD | | | | 🛒 |
|------------|----|------|----|---|
| 1 R-RT1-G | 4 | M5 | 25 | |
| 2 R-RT1-G | 4 | 1/8" | 25 | |
| 3 R-RT1-G | 4 | 1/4" | 25 | |
| 4 R-RT1-G | 6 | 1/8" | 25 | |
| 5 R-RT1-G | 6 | 1/4" | 25 | |
| 6 R-RT1-G | 8 | 1/8" | 25 | |
| 7 R-RT1-G | 8 | 1/4" | 25 | |
| 8 R-RT1-G | 8 | 3/8" | 25 | |
| 9 R-RT1-G | 10 | 1/4" | 25 | |
| 10 R-RT1-G | 10 | 3/8" | 25 | |
| 11 R-RT1-G | 12 | 1/4" | 25 | |
| 12 R-RT1-G | 12 | 3/8" | 25 | |
| 13 R-RT1-G | 14 | 1/2" | 25 | |

Cilindrico + OR
Parallel + OR



R-RT2-G

| COD | | | | 🛒 |
|------------|----|------|----|---|
| 1 R-RT2-G | 4 | M5 | 25 | |
| 2 R-RT2-G | 4 | 1/8" | 25 | |
| 3 R-RT2-G | 4 | 1/4" | 25 | |
| 4 R-RT2-G | 6 | 1/8" | 25 | |
| 5 R-RT2-G | 6 | 1/4" | 25 | |
| 6 R-RT2-G | 8 | 1/8" | 25 | |
| 7 R-RT2-G | 8 | 1/4" | 25 | |
| 8 R-RT2-G | 8 | 3/8" | 25 | |
| 9 R-RT2-G | 10 | 1/4" | 25 | |
| 10 R-RT2-G | 10 | 3/8" | 25 | |
| 11 R-RT2-G | 12 | 1/4" | 25 | |
| 12 R-RT2-G | 12 | 3/8" | 25 | |
| 13 R-RT2-G | 14 | 1/2" | 25 | |

Cilindrico + OR
Parallel + OR



R-RT

| COD | | | | 🛒 |
|---------|---------|--|----|---|
| 1 R-RT | 4 | | 25 | |
| 2 R-RT | 5 | | 25 | |
| 3 R-RT | 6 | | 25 | |
| 4 R-RT | 8 | | 25 | |
| 5 R-RT | 10 | | 25 | |
| 6 R-RT | 12 | | 25 | |
| 7 R-RT | 14 | | 25 | |
| 8 R-RT | 6-4-6 | | 25 | |
| 9 R-RT | 8-6-8 | | 25 | |
| 10 R-RT | 10-8-10 | | 25 | |



R-GP

| COD | | | | 🛒 |
|--------|----|--|----|---|
| 1 R-GP | 4 | | 25 | |
| 2 R-GP | 6 | | 25 | |
| 3 R-GP | 8 | | 25 | |
| 4 R-GP | 10 | | 25 | |
| 5 R-GP | 12 | | 25 | |



R-R

| COD | | | 🛒 |
|--------|----|----|----|
| 1 R-R | 4 | 6 | 25 |
| 2 R-R | 5 | 4 | 25 |
| 3 R-R | 6 | 4 | 25 |
| 4 R-R | 6 | 5 | 25 |
| 5 R-R | 6 | 8 | 25 |
| 6 R-R | 8 | 4 | 25 |
| 7 R-R | 8 | 5 | 25 |
| 8 R-R | 8 | 6 | 25 |
| 9 R-R | 10 | 6 | 25 |
| 10 R-R | 10 | 8 | 25 |
| 11 R-R | 12 | 4 | 25 |
| 12 R-R | 12 | 6 | 25 |
| 13 R-R | 12 | 8 | 25 |
| 14 R-R | 12 | 10 | 25 |
| 15 R-R | 14 | 4 | 25 |
| 16 R-R | 14 | 6 | 25 |
| 17 R-R | 14 | 8 | 25 |
| 18 R-R | 14 | 10 | 25 |
| 19 R-R | 14 | 12 | 25 |



R-AS

| COD | | | 🛒 |
|---------|----|------|----|
| 1 R-AS | 4 | M5 | 25 |
| 2 R-AS | 4 | 1/8" | 25 |
| 3 R-AS | 5 | M5 | 25 |
| 4 R-AS | 5 | 1/8" | 25 |
| 5 R-AS | 6 | 1/8" | 25 |
| 6 R-AS | 6 | 1/4" | 25 |
| 7 R-AS | 8 | 1/8" | 25 |
| 8 R-AS | 8 | 1/4" | 25 |
| 9 R-AS | 8 | 3/8" | 25 |
| 10 R-AS | 10 | 1/4" | 25 |
| 11 R-AS | 10 | 3/8" | 25 |
| 12 R-AS | 12 | 1/4" | 25 |
| 13 R-AS | 12 | 3/8" | 25 |



R-AD

| COD | | | 🛒 |
|---------|----|------|----|
| 1 R-AD | 4 | M5 | 25 |
| 2 R-AD | 4 | 1/8" | 25 |
| 3 R-AD | 5 | M5 | 25 |
| 4 R-AD | 5 | 1/8" | 25 |
| 5 R-AD | 6 | 1/8" | 25 |
| 6 R-AD | 6 | 1/4" | 25 |
| 7 R-AD | 8 | 1/8" | 25 |
| 8 R-AD | 8 | 1/4" | 25 |
| 9 R-AD | 8 | 3/8" | 25 |
| 10 R-AD | 10 | 1/4" | 25 |
| 11 R-AD | 10 | 3/8" | 25 |



R-ASF-1

| COD | | | 🛒 |
|------------|----|------|----|
| 1 R-ASF-1 | 4 | M5 | 25 |
| 2 R-ASF-1 | 4 | 1/8" | 25 |
| 3 R-ASF-1 | 5 | M5 | 25 |
| 4 R-ASF-1 | 5 | 1/8" | 25 |
| 5 R-ASF-1 | 6 | 1/8" | 25 |
| 6 R-ASF-1 | 8 | 1/8" | 25 |
| 7 R-ASF-1 | 6 | 1/4" | 25 |
| 8 R-ASF-1 | 8 | 1/4" | 25 |
| 9 R-ASF-1 | 10 | 1/4" | 25 |
| 10 R-ASF-1 | 8 | 3/8" | 25 |
| 11 R-ASF-1 | 10 | 3/8" | 25 |
| 12 R-ASF-1 | 12 | 1/4" | 25 |
| 13 R-ASF-1 | 12 | 3/8" | 25 |

Cilindrico + OR
Parallel + OR



R-ASF-2

| COD | | | 🛒 |
|-----------|----|------|----|
| 1 R-ASF-2 | 4 | 1/8" | 25 |
| 2 R-ASF-2 | 6 | 1/8" | 25 |
| 3 R-ASF-2 | 8 | 1/8" | 25 |
| 4 R-ASF-2 | 6 | 1/4" | 25 |
| 5 R-ASF-2 | 8 | 1/4" | 25 |
| 6 R-ASF-2 | 10 | 1/4" | 25 |
| 7 R-ASF-2 | 12 | 1/4" | 25 |

Cilindrico + OR
Parallel + OR



R-ASF-3

| COD | | | 🛒 |
|-----------|----|------|----|
| 1 R-ASF-3 | 4 | 1/8" | 25 |
| 2 R-ASF-3 | 6 | 1/8" | 25 |
| 3 R-ASF-3 | 8 | 1/8" | 25 |
| 4 R-ASF-3 | 6 | 1/4" | 25 |
| 5 R-ASF-3 | 8 | 1/4" | 25 |
| 6 R-ASF-3 | 10 | 1/4" | 25 |
| 7 R-ASF-3 | 12 | 1/4" | 25 |

Cilindrico + OR
Parallel + OR



R-AOS

| COD | | | 🛒 |
|----------|----|------|----|
| 1 R-AOS | 4 | M5 | 25 |
| 2 R-AOS | 4 | 1/8" | 25 |
| 3 R-AOS | 5 | M5 | 25 |
| 4 R-AOS | 5 | 1/8" | 25 |
| 5 R-AOS | 6 | M5 | 25 |
| 6 R-AOS | 6 | 1/8" | 25 |
| 7 R-AOS | 6 | 1/4" | 25 |
| 8 R-AOS | 8 | 1/8" | 25 |
| 9 R-AOS | 8 | 1/4" | 25 |
| 10 R-AOS | 8 | 3/8" | 25 |
| 11 R-AOS | 10 | 1/4" | 25 |
| 12 R-AOS | 10 | 3/8" | 25 |
| 13 R-AOS | 12 | 1/4" | 25 |
| 14 R-AOS | 12 | 3/8" | 25 |

Cilindrico + OR
Parallel + OR



R-AOD

| COD | | | 🛒 |
|----------|----|------|----|
| 1 R-AOD | 4 | M5 | 25 |
| 2 R-AOD | 4 | 1/8" | 25 |
| 3 R-AOD | 5 | M5 | 25 |
| 4 R-AOD | 5 | 1/8" | 25 |
| 5 R-AOD | 6 | 1/8" | 25 |
| 6 R-AOD | 6 | 1/4" | 25 |
| 7 R-AOD | 8 | 1/8" | 25 |
| 8 R-AOD | 8 | 1/4" | 25 |
| 9 R-AOD | 8 | 3/8" | 25 |
| 10 R-AOD | 10 | 1/4" | 25 |
| 11 R-AOD | 10 | 3/8" | 25 |
| 12 R-AOD | 12 | 3/8" | 25 |

Cilindrico + OR
Parallel + OR

RACCORDI RAPIDI STANDARD OTTONE - *PUSH-IN BRASS FITTINGS*

R-ADF-1



| COD | | | | 🛒 |
|------------|----|------|--|----|
| 1 R-ADF-1 | 4 | M5 | | 25 |
| 2 R-ADF-1 | 4 | 1/8" | | 25 |
| 3 R-ADF-1 | 5 | M5 | | 25 |
| 4 R-ADF-1 | 5 | 1/8" | | 25 |
| 5 R-ADF-1 | 6 | 1/8" | | 25 |
| 6 R-ADF-1 | 8 | 1/8" | | 25 |
| 7 R-ADF-1 | 6 | 1/4" | | 25 |
| 8 R-ADF-1 | 8 | 1/4" | | 25 |
| 9 R-ADF-1 | 10 | 1/4" | | 25 |
| 10 R-ADF-1 | 8 | 3/8" | | 25 |
| 11 R-ADF-1 | 10 | 3/8" | | 25 |
| 13 R-ADF-1 | 12 | 3/8" | | 25 |

Cilindrico + OR
Parallel + OR

R-RDF



| COD | | | | 🛒 |
|---------|---|------|--|----|
| 1 R-RDF | 4 | 1/8" | | 25 |
| 2 R-RDF | 4 | 1/4" | | 25 |
| 3 R-RDF | 5 | 1/8" | | 25 |
| 4 R-RDF | 5 | 1/4" | | 25 |
| 5 R-RDF | 6 | 1/8" | | 25 |
| 6 R-RDF | 6 | 1/4" | | 25 |
| 7 R-RDF | 8 | 1/8" | | 25 |
| 8 R-RDF | 8 | 1/4" | | 25 |

R-AC



| COD | | | | 🛒 |
|---------|----|------|--|----|
| 1 R-AC | 4 | M5 | | 25 |
| 2 R-AC | 4 | 1/8" | | 25 |
| 3 R-AC | 4 | 1/4" | | 25 |
| 4 R-AC | 5 | M5 | | 25 |
| 5 R-AC | 5 | 1/8" | | 25 |
| 6 R-AC | 5 | 1/4" | | 25 |
| 7 R-AC | 6 | M5 | | 25 |
| 8 R-AC | 6 | 1/8" | | 25 |
| 9 R-AC | 6 | 1/4" | | 25 |
| 10 R-AC | 8 | 1/8" | | 25 |
| 11 R-AC | 8 | 1/4" | | 25 |
| 12 R-AC | 8 | 3/8" | | 25 |
| 13 R-AC | 10 | 1/8" | | 25 |
| 14 R-AC | 10 | 1/4" | | 25 |
| 15 R-AC | 10 | 3/8" | | 25 |
| 16 R-AC | 12 | 1/4" | | 25 |
| 17 R-AC | 12 | 3/8" | | 25 |
| 18 R-AC | 12 | 1/2" | | 25 |
| 19 R-AC | 14 | 3/8" | | 25 |
| 20 R-AC | 14 | 1/2" | | 25 |

Cilindrico + OR
Parallel + OR

R-AL



| COD | | | | 🛒 |
|--------|----|------|--|----|
| 1 R-AL | 4 | M7 | | 25 |
| 2 R-AL | 4 | 1/8" | | 25 |
| 3 R-AL | 6 | M7 | | 25 |
| 4 R-AL | 6 | 1/8" | | 25 |
| 5 R-AL | 6 | 1/4" | | 25 |
| 6 R-AL | 8 | 1/8" | | 25 |
| 7 R-AL | 8 | 1/4" | | 25 |
| 8 R-AL | 10 | 1/4" | | 25 |

Cilindrico + OR
Parallel + OR

R-TM



| COD | | | | 🛒 |
|--------|----|--|--|----|
| 1 R-TM | 4 | | | 25 |
| 2 R-TM | 5 | | | 25 |
| 3 R-TM | 6 | | | 25 |
| 4 R-TM | 8 | | | 25 |
| 5 R-TM | 10 | | | 25 |
| 6 R-TM | 12 | | | 25 |
| 7 R-TM | 14 | | | 25 |

Tappo Maschio
Male Plug

R-TF



| COD | | | | 🛒 |
|--------|----|--|--|----|
| 1 R-TF | 4 | | | 25 |
| 2 R-TF | 6 | | | 25 |
| 3 R-TF | 8 | | | 25 |
| 4 R-TF | 10 | | | 25 |
| 5 R-TF | 12 | | | 25 |

Bussola
Insert fitting

R-RP



| COD | | | | 🛒 |
|--------|----|----------|--|----|
| 1 R-RP | 4 | M 10 x 1 | | 25 |
| 2 R-RP | 5 | M 11 x 1 | | 25 |
| 3 R-RP | 6 | M 14 x 1 | | 25 |
| 4 R-RP | 8 | M 16 x 1 | | 25 |
| 5 R-RP | 10 | M 17 x 1 | | 25 |
| 6 R-RP | 12 | M 20 x 1 | | 25 |
| 7 R-RP | 14 | M 22 x 1 | | 25 |

Passaparete
Bulkhead

R-P



| COD | | | | 🛒 |
|-------|----|--|--|----|
| 1 R-P | 4 | | | 25 |
| 2 R-P | 5 | | | 25 |
| 3 R-P | 6 | | | 25 |
| 4 R-P | 8 | | | 25 |
| 5 R-P | 10 | | | 25 |
| 6 R-P | 12 | | | 25 |
| 7 R-P | 14 | | | 25 |

| R-RL | | | |
|---|---------|------|----|
| COD | | | 🛒 |
|  | 1 R-RL | 4 | 25 |
| | 2 R-RL | 5 | 25 |
| | 3 R-RL | 6 | 25 |
| | 4 R-RL | 8 | 25 |
| | 5 R-RL | 10 | 25 |
| | 6 R-RL | 12 | 25 |
| | 7 R-RL | 14 | 25 |
| | 8 R-RL | 6-4 | 25 |
| | 9 R-RL | 8-6 | 25 |
| | 10 R-RL | 10-8 | 25 |

| DC | | | |
|---|------|------|---|
| COD | | | 🛒 |
|  | 1 DC | 8 14 | 1 |

Disinnestatore
Tool for disassembling

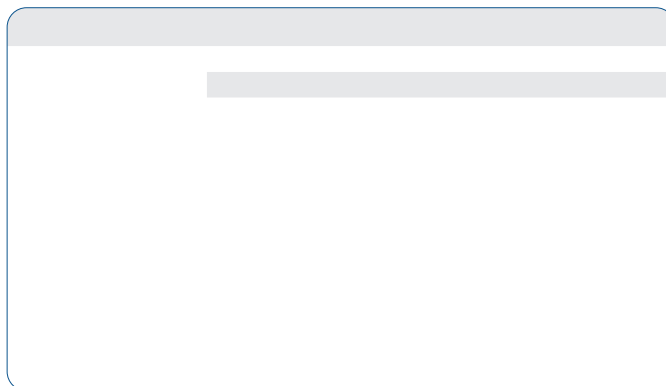
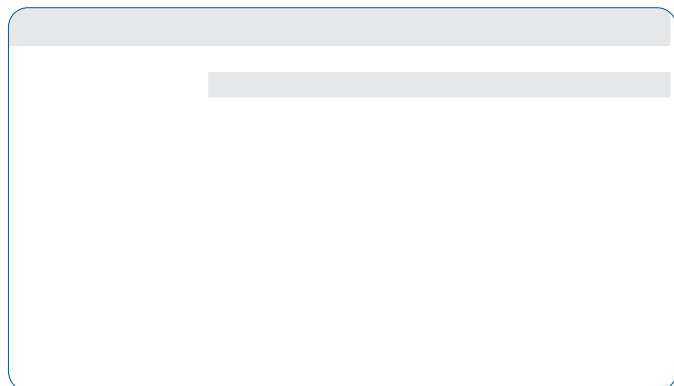

SEZIONE RACCORDO RAPIDO - *PUSH-IN FITTING SECTION*

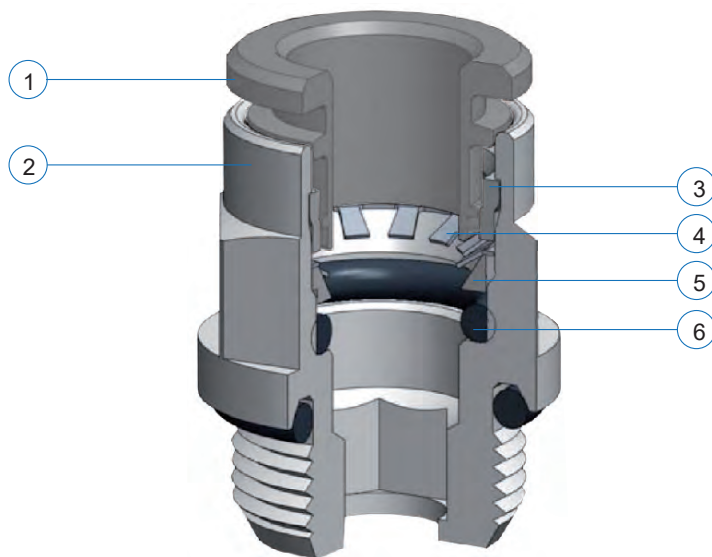

| NUMERO | DENOMINAZIONE | NUMBER | NAME |
|--------|--------------------|--------|--------------------------|
| 1 | ANELLO ESTRATTORE | 1 | THRUST RING |
| 2 | CORPO | 2 | BODY |
| 3 | ANELLO DI TENUTA | 3 | NBR PACKING RING |
| 4 | PINZA AGGRAFFAGGIO | 4 | CLAMP |
| 5 | ANELLO PORTA PINZA | 5 | CLAMP RING |
| 6 | GUARNIZIONI | 6 | SILICON FREE NBR O-RINGS |

RACCORDI RAPIDI OTTONE TIPO "W" - "W" TYPE PUSH-IN BRASS FITTINGS

WPC-C



| COD | | | | 🛒 |
|-------------|----|------|----|----|
| WPC-C 6-01 | 6 | 1/8" | 25 | 25 |
| WPC-C 6-02 | 6 | 1/4" | 25 | 25 |
| WPC-C 6-03 | 6 | 3/8" | 25 | 25 |
| WPC-C 6-04 | 6 | 1/2" | 25 | 25 |
| WPC-C 8-01 | 8 | 1/8" | 25 | 25 |
| WPC-C 8-02 | 8 | 1/4" | 25 | 25 |
| WPC-C 8-03 | 8 | 3/8" | 25 | 25 |
| WPC-C 8-04 | 8 | 1/2" | 25 | 25 |
| WPC-C 10-01 | 10 | 1/8" | 25 | 25 |
| WPC-C 10-02 | 10 | 1/4" | 25 | 25 |
| WPC-C 10-03 | 10 | 3/8" | 25 | 25 |
| WPC-C 10-04 | 10 | 1/2" | 25 | 25 |
| WPC-C 12-02 | 12 | 1/4" | 25 | 25 |
| WPC-C 12-03 | 12 | 3/8" | 25 | 25 |
| WPC-C 12-04 | 12 | 1/2" | 25 | 25 |

Conico - *Taper*

WPC-G



| COD | | | | 🛒 |
|-------------|----|------|----|----|
| WPC-G 6-01 | 6 | 1/8" | 25 | 25 |
| WPC-G 6-02 | 6 | 1/4" | 25 | 25 |
| WPC-G 6-03 | 6 | 3/8" | 25 | 25 |
| WPC-G 4-04 | 6 | 1/2" | 25 | 25 |
| WPC-G 8-01 | 8 | 1/8" | 25 | 25 |
| WPC-G 8-02 | 8 | 1/4" | 25 | 25 |
| WPC-G 8-03 | 8 | 3/8" | 25 | 25 |
| WPC-G 8-04 | 8 | 1/2" | 25 | 25 |
| WPC-G 10-01 | 10 | 1/8" | 25 | 25 |
| WPC-G 10-02 | 10 | 1/4" | 25 | 25 |
| WPC-G 10-03 | 10 | 3/8" | 25 | 25 |
| WPC-G 10-04 | 10 | 1/2" | 25 | 25 |
| WPC-G 12-02 | 12 | 1/4" | 25 | 25 |
| WPC-G 12-03 | 12 | 3/8" | 25 | 25 |
| WPC-G 12-04 | 12 | 1/2" | 25 | 25 |

Cilindrico - *Parallel*

WPCF



| COD | | | | 🛒 |
|------------|----|------|----|----|
| WPCF 6-01 | 6 | 1/8" | 25 | 25 |
| WPCF 6-02 | 6 | 1/4" | 25 | 25 |
| WPCF 6-03 | 6 | 3/8" | 25 | 25 |
| WPCF 6-04 | 6 | 1/2" | 25 | 25 |
| WPCF 8-01 | 8 | 1/8" | 25 | 25 |
| WPCF 8-02 | 8 | 1/4" | 25 | 25 |
| WPCF 8-03 | 8 | 3/8" | 25 | 25 |
| WPCF 8-04 | 8 | 1/2" | 25 | 25 |
| WPCF 10-01 | 10 | 1/8" | 25 | 25 |
| WPCF 10-02 | 10 | 1/4" | 25 | 25 |
| WPCF 10-03 | 10 | 3/8" | 25 | 25 |
| WPCF 10-04 | 10 | 1/2" | 25 | 25 |
| WPCF 12-02 | 12 | 1/4" | 25 | 25 |
| WPCF 12-03 | 12 | 3/8" | 25 | 25 |
| WPCF 12-04 | 12 | 1/2" | 25 | 25 |

WPUC



| COD | | | 🛒 |
|---------|----|--|----|
| WPUC 6 | 6 | | 25 |
| WPUC 8 | 8 | | 25 |
| WPUC 10 | 10 | | 25 |
| WPUC 12 | 12 | | 25 |

WPMM



| COD | | | 🛒 |
|---------|----|--|----|
| WPMM 6 | 6 | | 25 |
| WPMM 8 | 8 | | 25 |
| WPMM 10 | 10 | | 25 |
| WPMM 12 | 12 | | 25 |

WPL-C



| COD | | | | 🛒 |
|-------------|----|------|----|----|
| WPL-C 6-01 | 6 | 1/8" | 25 | 25 |
| WPL-C 6-02 | 6 | 1/4" | 25 | 25 |
| WPL-C 6-03 | 6 | 3/8" | 25 | 25 |
| WPL-C 6-04 | 6 | 1/2" | 25 | 25 |
| WPL-C 8-01 | 8 | 1/8" | 25 | 25 |
| WPL-C 8-02 | 8 | 1/4" | 25 | 25 |
| WPL-C 8-03 | 8 | 3/8" | 25 | 25 |
| WPL-C 8-04 | 8 | 1/2" | 25 | 25 |
| WPL-C 10-01 | 10 | 1/8" | 25 | 25 |
| WPL-C 10-02 | 10 | 1/4" | 25 | 25 |
| WPL-C 10-03 | 10 | 3/8" | 25 | 25 |
| WPL-C 10-04 | 10 | 1/2" | 25 | 25 |
| WPL-C 12-02 | 12 | 1/4" | 25 | 25 |
| WPL-C 12-03 | 12 | 3/8" | 25 | 25 |
| WPL-C 12-04 | 12 | 1/2" | 25 | 25 |

Conico - *Taper*

WPL-G



| COD | | | | 🛒 |
|-------------|----|------|----|----|
| WPL-G 6-01 | 6 | 1/8" | 25 | 25 |
| WPL-G 6-02 | 6 | 1/4" | 25 | 25 |
| WPL-G 6-03 | 6 | 3/8" | 25 | 25 |
| WPL-G 4-04 | 6 | 1/2" | 25 | 25 |
| WPL-G 8-01 | 8 | 1/8" | 25 | 25 |
| WPL-G 8-02 | 8 | 1/4" | 25 | 25 |
| WPL-G 8-03 | 8 | 3/8" | 25 | 25 |
| WPL-G 8-04 | 8 | 1/2" | 25 | 25 |
| WPL-G 10-01 | 10 | 1/8" | 25 | 25 |
| WPL-G 10-02 | 10 | 1/4" | 25 | 25 |
| WPL-G 10-03 | 10 | 3/8" | 25 | 25 |
| WPL-G 10-04 | 10 | 1/2" | 25 | 25 |
| WPL-G 12-02 | 12 | 1/4" | 25 | 25 |
| WPL-G 12-03 | 12 | 3/8" | 25 | 25 |
| WPL-G 12-04 | 12 | 1/2" | 25 | 25 |

Cilindrico - *Parallel*



WPUL

| COD | | 1/16" |
|---------|----|-------|
| WPUL 6 | 6 | 25 |
| WPUL 8 | 8 | 25 |
| WPUL 10 | 10 | 25 |
| WPUL 12 | 12 | 25 |



WPUT

| COD | | 1/16" |
|---------|----|-------|
| WPUT 6 | 6 | 25 |
| WPUT 8 | 8 | 25 |
| WPUT 10 | 10 | 25 |
| WPUT 12 | 12 | 25 |



WPT-C

| COD | | 1/16" |
|-----------|----|-------|
| WPT 6-01 | 6 | 1/8" |
| WPT 6-02 | 6 | 1/4" |
| WPT 6-03 | 6 | 3/8" |
| WPT 6-04 | 6 | 1/2" |
| WPT 8-01 | 8 | 1/8" |
| WPT 8-02 | 8 | 1/4" |
| WPT 8-03 | 8 | 3/8" |
| WPT 8-04 | 8 | 1/2" |
| WPT 10-01 | 10 | 1/8" |
| WPT 10-02 | 10 | 1/4" |
| WPT 10-03 | 10 | 3/8" |
| WPT 10-04 | 10 | 1/2" |
| WPT 12-02 | 12 | 1/4" |
| WPT 12-03 | 12 | 3/8" |
| WPT 12-04 | 12 | 1/2" |

Conico teflonato
Taper with teflon



WPT-G

| COD | | 1/16" |
|-------------|----|-------|
| WPT-G 6-01 | 6 | 1/8" |
| WPT-G 6-02 | 6 | 1/4" |
| WPT-G 6-03 | 6 | 3/8" |
| WPT-G 4-04 | 6 | 1/2" |
| WPT-G 8-01 | 8 | 1/8" |
| WPT-G 8-02 | 8 | 1/4" |
| WPT-G 8-03 | 8 | 3/8" |
| WPT-G 8-04 | 8 | 1/2" |
| WPT-G 10-01 | 10 | 1/8" |
| WPT-G 10-02 | 10 | 1/4" |
| WPT-G 10-03 | 10 | 3/8" |
| WPT-G 10-04 | 10 | 1/2" |
| WPT-G 12-02 | 12 | 1/4" |
| WPT-G 12-03 | 12 | 3/8" |
| WPT-G 12-04 | 12 | 1/2" |

Cilindrico + OR
Parallel + OR



WPST-C

| COD | | 1/16" |
|--------------|----|-------|
| WPST-C 6-01 | 6 | 1/8" |
| WPST-C 6-02 | 6 | 1/4" |
| WPST-C 6-03 | 6 | 3/8" |
| WPST-C 6-04 | 6 | 1/2" |
| WPST-C 8-01 | 8 | 1/8" |
| WPST-C 8-02 | 8 | 1/4" |
| WPST-C 8-03 | 8 | 3/8" |
| WPST-C 8-04 | 8 | 1/2" |
| WPST-C 10-01 | 10 | 1/8" |
| WPST-C 10-02 | 10 | 1/4" |
| WPST-C 10-03 | 10 | 3/8" |
| WPST-C 10-04 | 10 | 1/2" |
| WPST-C 12-02 | 12 | 1/4" |
| WPST-C 12-03 | 12 | 3/8" |
| WPST-C 12-04 | 12 | 1/2" |

Conico teflonato
Taper with teflon



WPST-G

| COD | | 1/16" |
|--------------|----|-------|
| WPST-G 6-01 | 6 | 1/8" |
| WPST-G 6-02 | 6 | 1/4" |
| WPST-G 6-03 | 6 | 3/8" |
| WPST-G 4-04 | 6 | 1/2" |
| WPST-G 8-01 | 8 | 1/8" |
| WPST-G 8-02 | 8 | 1/4" |
| WPST-G 8-03 | 8 | 3/8" |
| WPST-G 8-04 | 8 | 1/2" |
| WPST-G 10-01 | 10 | 1/8" |
| WPST-G 10-02 | 10 | 1/4" |
| WPST-G 10-03 | 10 | 3/8" |
| WPST-G 10-04 | 10 | 1/2" |
| WPST-G 12-02 | 12 | 1/4" |
| WPST-G 12-03 | 12 | 3/8" |
| WPST-G 12-04 | 12 | 1/2" |

Cilindrico + OR
Parallel + OR

RACCORDO TIPO "W" - PUSH-IN FITTING "W" TYPE

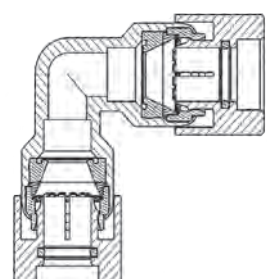

Il raccordo tipo "W", grazie alle tenute in viton®, può essere impiegato in zone ad alta temperatura.
Le generose dimensioni dell'anello di sgancio facilitano le operazioni di smontaggio del tubo dal raccordo stesso.

*The Push-in fitting type thanks to viton® seals, can be used at high temperatures.
The dimensions of the thrust ring make it easy to disassemble the tube from the fitting itself.*



RH-RDM

Alta pressione 250 Bar
High pressure 250 Bar



RH-RG1-G

Alta pressione 250 Bar
High pressure 250 Bar

| RH-RDM | | | | |
|----------|---|--------|--|----|
| COD | | | | |
| | | | | 10 |
| 1 RH-RDM | 4 | M6 | | 10 |
| 2 RH-RDM | 4 | M8 | | 10 |
| 3 RH-RDM | 4 | M10 | | 10 |
| 4 RH-RDM | 4 | G 1/8" | | 10 |
| 5 RH-RDM | 6 | M8 | | 10 |
| 6 RH-RDM | 6 | M10 | | 10 |
| 7 RH-RDM | 6 | G 1/8" | | 10 |
| 8 RH-RDM | 6 | G 1/4" | | 10 |

Alta pressione 250 Bar - *High pressure 250 Bar*

| RH-RG1-G | | | | |
|------------|---|--------|--|----|
| COD | | | | |
| | | | | 10 |
| 1 RH-RG1-G | 4 | M6 | | 10 |
| 1 RH-RG1-G | 4 | M8 | | 10 |
| 1 RH-RG1-G | 4 | M10 | | 10 |
| 1 RH-RG1-G | 4 | G 1/8" | | 10 |
| 1 RH-RG1-G | 6 | M8 | | 10 |
| 1 RH-RG1-G | 6 | M10 | | 10 |
| 1 RH-RG1-G | 6 | G 1/8" | | 10 |
| 1 RH-RG1-G | 6 | G 1/4" | | 10 |

Alta pressione 250 Bar - *High pressure 250 Bar*









































Per maggiori chiarimenti, specifiche e prezzi contattare il nostro Ufficio Commerciale.
For further clarifications, specifications and prices, contact our Sales Office.



STAINLESS STEEL FITTINGS

| | | | | | | |
|---|------------|---|--|--|----------|----|
|  | RMFX-M | 85 |  | MX | 86 | |
|  | NX-C-M | 85 |  | PMFX | 86 | |
|  | RMX-M | 85 |  | RMF-X | 86 | |
|  | MX-M | 85 |  | RGX-FF | 86 | |
|  | RGX-MF-M-C | 85 |  | RGX-C-MF | 86 | |
|  | RGX-FF-M | 85 |  | RTX-FFF | 86 | |
|  | GX-FF-M |  | 85 |  | RTX-FMF | 86 |
|  | RTX-FFF-M | 85 |  | RMF-C-X | 86 | |
|  | RXX-4F-M | 85 |  | TX | 86 | |
|  | TX-M | 85 |  | RMFX-A | 87 | |
|  | PX-C-M | 85 |  | NX-A | 87 | |
|  | N-C-X |  | 86 |  | RGX-A-FF | 87 |

| | | | | | |
|---|-----------|----|---|-----------|----|
|  | RGX-A-MM | 87 |  | RX-RG | 88 |
|  | RGX-A-MF | 87 |  | RX-RG1-C | 88 |
|  | RTX-A-FMF | 87 |  | RX-RG1-G | 88 |
|  | RTX-A-MMM | 87 |  | RX-RG1-CG | 88 |
|  | RTX-A-FFF | 87 |  | RX-RA | 88 |
|  | RXX-A-4F | 87 |  | RX-RL | 88 |
|  | RXX-A-4M | 87 |  | RX-RT | 88 |
|  | TX-A-F | 87 |  | RX-RT2-G | 88 |
|  | TX-A-M | 87 |  | RX-RT2-CG | 89 |
|  | RX-RDM | 88 |  | RX-AS-C1 | 89 |
|  | RX-RDMC | 88 |  | RX-RP | 89 |

| | | | | | |
|---|--------|----|--|----------|----|
|  | RX-RPG | 89 |  | RGS-X | 90 |
|  | RX-PLF | 89 |  | RX-RYTTT | 90 |
|  | RX-PST | 89 |  | RDMX-C | 91 |
|  | RX-POC | 89 |  | RG-1X-C | 91 |
|  | RX-YTT | 89 |  | RG-2X-C | 91 |
|  | RX-4T | 89 |  | RDX | 91 |
|  | RX-5T | 89 |  | RGX | 91 |
|  | RX-FRP | 90 |  | RTX | 91 |
|  | RX-RTT | 90 |  | RG-3X | 91 |
|  | RX-SC | 90 |  | RT-1X-C | 91 |
|  | RX-SCI | 90 |  | RPX | 91 |

RMFX-M



| COD | | | |
|-----------|-----------------|----|--|
| 1 RMFX-M | 1/4" - 1/8" | 10 | |
| 2 RMFX-M | 3/8" - 1/4" | 10 | |
| 3 RMFX-M | 1/2" - 3/8" | 10 | |
| 4 RMFX-M | 3/4" - 1/2" | 10 | |
| 5 RMFX-M | 1" - 3/4" | 10 | |
| 6 RMFX-M | 1" 1/4 - 1" | 10 | |
| 7 RMFX-M | 1" 1/2 - 1" 1/4 | 10 | |
| 8 RMFX-M | 2" - 1" 1/2 | 10 | |
| 9 RMFX-M | 3/4" - 1" 1/2 | 10 | |
| 10 RMFX-M | 1" - 2" | 10 | |

Cilindrico - *Parallel*
AISI 304 / 316

NX-C-M



| COD | | | |
|----------|-----------------|----|--|
| 1 NX-C-M | 1/8" - 1/8" | 10 | |
| 2 NX-C-M | 1/4" - 1/4" | 10 | |
| 3 NX-C-M | 3/8" - 3/8" | 10 | |
| 4 NX-C-M | 1/2" - 1/2" | 10 | |
| 5 NX-C-M | 3/4" - 3/4" | 10 | |
| 6 NX-C-M | 1" - 1" | 10 | |
| 7 NX-C-M | 1" 1/4 - 1" 1/4 | 1 | |
| 8 NX-C-M | 1" 1/2 - 1" 1/2 | 1 | |
| 9 NX-C-M | 2" - 2" | 1 | |

Conico - *Taper*
AISI 304 / 316

RMX-M



| COD | | | |
|---------|--------|----|--|
| 2 RMX-M | 1/4" | 10 | |
| 3 RMX-M | 3/8" | 10 | |
| 4 RMX-M | 1/2" | 10 | |
| 5 RMX-M | 3/4" | 10 | |
| 6 RMX-M | 1" | 10 | |
| 7 RMX-M | 1" 1/4 | 5 | |
| 8 RMX-M | 1" 1/2 | 5 | |
| 9 RMX-M | 2" | 5 | |

Cilindrico - *Parallel*
AISI 304 / 316

MX-M



| COD | | | |
|--------|--------|----|--|
| 1 MX-M | 1/8" | 10 | |
| 2 MX-M | 1/4" | 10 | |
| 3 MX-M | 3/8" | 10 | |
| 4 MX-M | 1/2" | 10 | |
| 5 MX-M | 3/4" | 10 | |
| 6 MX-M | 1" | 10 | |
| 7 MX-M | 1" 1/4 | 5 | |
| 8 MX-M | 1" 1/2 | 5 | |
| 9 MX-M | 2" | 5 | |

AISI 304 / 316

RGX-MF-M-C



| COD | | | |
|--------------|--------|----|--|
| 1 RGX-MF-M-C | 1/8" | 10 | |
| 2 RGX-MF-M-C | 1/4" | 10 | |
| 3 RGX-MF-M-C | 3/8" | 10 | |
| 4 RGX-MF-M-C | 1/2" | 10 | |
| 5 RGX-MF-M-C | 3/4" | 10 | |
| 6 RGX-MF-M-C | 1" | 10 | |
| 7 RGX-MF-M-C | 1" 1/4 | 5 | |
| 8 RGX-MF-M-C | 1" 1/2 | 5 | |
| 9 RGX-MF-M-C | 2" | 5 | |

Conico - *Taper*
AISI 304 / 316

RGX-FF-M



| COD | | | |
|------------|--------|----|--|
| 1 RGX-FF-M | 1/8" | 10 | |
| 2 RGX-FF-M | 1/4" | 10 | |
| 3 RGX-FF-M | 3/8" | 10 | |
| 4 RGX-FF-M | 1/2" | 10 | |
| 5 RGX-FF-M | 3/4" | 10 | |
| 6 RGX-FF-M | 1" | 10 | |
| 7 RGX-FF-M | 1" 1/4 | 5 | |
| 8 RGX-FF-M | 1" 1/2 | 5 | |
| 9 RGX-FF-M | 2" | 5 | |

AISI 304 / 316

GX-FF-M



| COD | | | |
|-----------|--------|----|--|
| 1 GX FF-M | 1/8" | 10 | |
| 2 GX FF-M | 1/4" | 10 | |
| 3 GX FF-M | 3/8" | 10 | |
| 4 GX FF-M | 1/2" | 10 | |
| 5 GX FF-M | 3/4" | 10 | |
| 6 GX FF-M | 1" | 10 | |
| 7 GX FF-M | 1" 1/4 | 5 | |
| 8 GX FF-M | 1" 1/2 | 5 | |
| 9 GX FF-M | 2" | 5 | |

3 Pezzi - *3 Pieces*
AISI 304 / 316

RTX-FFF-M



| COD | | | |
|-------------|--------|----|--|
| 1 RTX-FFF-M | 1/8" | 10 | |
| 2 RTX-FFF-M | 1/4" | 10 | |
| 3 RTX-FFF-M | 3/8" | 10 | |
| 4 RTX-FFF-M | 1/2" | 10 | |
| 5 RTX-FFF-M | 3/4" | 10 | |
| 6 RTX-FFF-M | 1" | 10 | |
| 7 RTX-FFF-M | 1" 1/4 | 5 | |
| 8 RTX-FFF-M | 1" 1/2 | 5 | |
| 9 RTX-FFF-M | 2" | 5 | |

AISI 304 / 316

RXX-4F-M



| COD | | | |
|------------|--------|----|--|
| 1 RXX-4F-M | 1/8" | 10 | |
| 2 RXX-4F-M | 1/4" | 10 | |
| 3 RXX-4F-M | 3/8" | 10 | |
| 4 RXX-4F-M | 1/2" | 10 | |
| 5 RXX-4F-M | 3/4" | 10 | |
| 6 RXX-4F-M | 1" | 10 | |
| 7 RXX-4F-M | 1" 1/4 | 5 | |
| 8 RXX-4F-M | 1" 1/2 | 5 | |
| 9 RXX-4F-M | 2" | 5 | |

AISI 304 / 316

TX-M



| COD | | | |
|--------|--------|----|--|
| 1 TX-M | 1/8" | 10 | |
| 2 TX-M | 1/4" | 10 | |
| 3 TX-M | 3/8" | 10 | |
| 4 TX-M | 1/2" | 10 | |
| 5 TX-M | 3/4" | 10 | |
| 6 TX-M | 1" | 10 | |
| 7 TX-M | 1" 1/4 | 5 | |
| 8 TX-M | 1" 1/2 | 5 | |
| 9 TX-M | 2" | 5 | |

Cilindrico - *Parallel*
AISI 304 / 316

PX-C-M



| COD | | | |
|-----------|------------------|------|----|
| 1 PX-C-M | 1/8" tubo-tube | 7 | 10 |
| 2 PX-C-M | 1/4" tubo-tube | 9 | 10 |
| 3 PX-C-M | 3/8" tubo-tube | 11 | 10 |
| 4 PX-C-M | 1/2" tubo-tube | 15 | 10 |
| 5 PX-C-M | 3/4" tubo-tube | 20 | 10 |
| 6 PX-C-M | 1" tubo-tube | 26 | 10 |
| 7 PX-C-M | 1" 1/4 tubo-tube | 34,0 | 5 |
| 8 PX-C-M | 1" 1/2 tubo-tube | 40,5 | 5 |
| 9 PX-C-M | 2" tubo-tube | 52,5 | 5 |
| 10 PX-C-M | 2" 1/4 tubo-tube | 53,5 | 5 |
| 11 PX-C-M | 2" 1/2 tubo-tube | 63,5 | 5 |
| 12 PX-C-M | 3" tubo-tube | 76,1 | 5 |

Conico - *Taper*
AISI 304 / 316

VERSIONE STANDARD: AISI 316 - A RICHIESTA DISPONIBILE IN AISI 304 - STANDARD VERSION: AISI 316 - AVAILABLE IN AISI 304 ON REQUEST

RACCORDI STANDARD INOX AISI 316 L - AISI 316 L STAINLESS STEEL STANDARD FITTINGS

N-C-X



| COD | | 🛒 |
|----------|-------------|----|
| 1 N-C-X | 1/8" - 1/8" | 10 |
| 2 N-C-X | 1/4" - 1/4" | 10 |
| 3 N-C-X | 3/8" - 3/8" | 10 |
| 4 N-C-X | 1/2" - 1/2" | 10 |
| 5 N-C-X | 3/4" - 3/4" | 10 |
| 6 N-C-X | 1/8" - 1/4" | 10 |
| 7 N-C-X | 1/8" - 3/8" | 10 |
| 8 N-C-X | 1/4" - 3/8" | 10 |
| 9 N-C-X | 1/4" - 1/2" | 10 |
| 10 N-C-X | 3/8" - 1/2" | 10 |

Conico - Taper
AISI 316 L

MX



| COD | | 🛒 |
|-------|-------------|----|
| 1 MX | 1/8" - 1/8" | 10 |
| 2 MX | 1/4" - 1/4" | 10 |
| 3 MX | 3/8" - 3/8" | 10 |
| 4 MX | 1/2" - 1/2" | 10 |
| 5 MX | 3/4" - 3/4" | 10 |
| 6 MX | 1/8" - 1/4" | 10 |
| 7 MX | 1/8" - 3/8" | 10 |
| 8 MX | 1/4" - 3/8" | 10 |
| 9 MX | 1/4" - 1/2" | 10 |
| 10 MX | 3/8" - 1/2" | 10 |

AISI 316 L

PMFX



| COD | | 🛒 |
|--------|-------------|----|
| 1 PMFX | 1/8" - 1/4" | 10 |
| 2 PMFX | 1/4" - 3/8" | 10 |
| 3 PMFX | 1/4" - 1/2" | 10 |
| 4 PMFX | 3/8" - 1/2" | 10 |
| 5 PMFX | 1/2" - 3/4" | 10 |

AISI 316 L

RMF-X



| COD | | 🛒 |
|---------|-------------|----|
| 1 RMF-X | 1/8" - 1/4" | 10 |
| 2 RMF-X | 1/4" - 3/8" | 10 |
| 3 RMF-X | 1/4" - 1/2" | 10 |
| 4 RMF-X | 3/8" - 1/2" | 10 |
| 5 RMF-X | 1/2" - 3/4" | 10 |

AISI 316 L

RGX-FF



| COD | | 🛒 |
|----------|------|----|
| 1 RGX-FF | 1/8" | 10 |
| 2 RGX-FF | 1/4" | 10 |
| 3 RGX-FF | 3/8" | 10 |
| 4 RGX-FF | 1/2" | 10 |

AISI 316 L

RGX-C-MF



| COD | | 🛒 |
|------------|------|----|
| 1 RGX-C-MF | 1/8" | 10 |
| 2 RGX-C-MF | 1/4" | 10 |
| 3 RGX-C-MF | 3/8" | 10 |
| 4 RGX-C-MF | 1/2" | 10 |

Conico - Taper
AISI 316 L

RTX-FFF



| COD | | 🛒 |
|-----------|------|----|
| 1 RTX-FFF | 1/8" | 10 |
| 2 RTX-FFF | 1/4" | 10 |
| 3 RTX-FFF | 3/8" | 10 |
| 4 RTX-FFF | 1/2" | 10 |

AISI 316 L

RTX-C-FMF



| COD | | 🛒 |
|-------------|------|----|
| 1 RTX-C-FMF | 1/8" | 10 |
| 2 RTX-C-FMF | 1/4" | 10 |
| 3 RTX-C-FMF | 3/8" | 10 |
| 4 RTX-C-FMF | 1/2" | 10 |

Conico - Taper
AISI 316 L

RMF-C-X



| COD | | 🛒 |
|-----------|-------------|----|
| 1 RMF-C-X | 1/4" - 1/8" | 10 |
| 2 RMF-C-X | 3/4" - 1/8" | 10 |
| 3 RMF-C-X | 3/8" - 1/4" | 10 |
| 4 RMF-C-X | 1/2" - 1/4" | 10 |
| 5 RMF-C-X | 1/2" - 3/8" | 10 |
| 6 RMF-C-X | 3/4" - 1/2" | 10 |

Conico - Taper
AISI 316 L

TX



| COD | | 🛒 |
|------|------|----|
| 1 TX | 1/8" | 10 |
| 2 TX | 1/4" | 10 |
| 3 TX | 3/8" | 10 |
| 4 TX | 1/2" | 10 |
| 5 TX | 3/4" | 10 |

AISI 316 L

I RACCORDI STANDARD IN AISI 316L SONO DISPONIBILI SIA CON FILETTATURA CONICA CHE CON FILETTATURA CILINDRICA + GUARNIZIONE IN VITON.

THE STANDARD FITTINGS IN AISI 316L ARE AVAILABLE WITH BOTH TAPERED THREADS THAN WITH PARALLEL THREAD + VITON GASKET.

RMFX-A



| COD | | 🛒 |
|----------|-------------|----|
| 1 RMFX-A | 1/4" - 1/8" | 10 |
| 2 RMFX-A | 3/8" - 1/4" | 10 |
| 3 RMFX-A | 1/2" - 3/8" | 10 |
| 4 RMFX-A | 3/4" - 1/2" | 10 |
| 5 RMFX-A | 1" - 3/4" | 10 |

Cilindrico - *Parallel*
AISI 316 L

NX-A



| COD | | 🛒 |
|--------|------|----|
| 1 NX-A | 1/8" | 10 |
| 2 NX-A | 1/4" | 10 |
| 3 NX-A | 3/8" | 10 |
| 4 NX-A | 1/2" | 10 |
| 5 NX-A | 3/4" | 10 |
| 6 NX-A | 1" | 10 |

Cilindrico - *Parallel*
AISI 316 L

RGX-A-FF



| COD | | 🛒 |
|------------|------|----|
| 1 RGX-A-FF | 1/8" | 10 |
| 2 RGX-A-FF | 1/4" | 10 |
| 3 RGX-A-FF | 3/8" | 10 |
| 4 RGX-A-FF | 1/2" | 10 |
| 5 RGX-A-FF | 3/4" | 10 |
| 6 RGX-A-FF | 1" | 5 |

AISI 316 L

RGX-A-MM



| COD | | 🛒 |
|------------|------|----|
| 1 RGX-A-MM | 1/8" | 10 |
| 2 RGX-A-MM | 1/4" | 10 |
| 3 RGX-A-MM | 3/8" | 10 |
| 4 RGX-A-MM | 1/2" | 10 |
| 5 RGX-A-MM | 3/4" | 10 |
| 6 RGX-A-MM | 1" | 10 |

Cilindrico - *Parallel*
AISI 316 L

RGX-A-MF



| COD | | 🛒 |
|------------|------|----|
| 1 RGX-A-MF | 1/8" | 10 |
| 2 RGX-A-MF | 1/4" | 10 |
| 3 RGX-A-MF | 3/8" | 10 |
| 4 RGX-A-MF | 1/2" | 10 |
| 5 RGX-A-MF | 3/4" | 10 |
| 6 RGX-A-MF | 1" | 10 |

Cilindrico - *Parallel*
AISI 316 L

RTX-A-FMF



| COD | | 🛒 |
|-------------|------|----|
| 1 RTX-A-FMF | 1/8" | 10 |
| 2 RTX-A-FMF | 1/4" | 10 |
| 3 RTX-A-FMF | 3/8" | 10 |
| 4 RTX-A-FMF | 1/2" | 10 |
| 5 RTX-A-FMF | 3/4" | 10 |
| 6 RTX-A-FMF | 1" | 10 |

Cilindrico - *Parallel*
AISI 316 L

RTX-A-MMM



| COD | | 🛒 |
|-------------|------|----|
| 1 RTX-A-MMM | 1/8" | 10 |
| 2 RTX-A-MMM | 1/4" | 10 |
| 3 RTX-A-MMM | 3/8" | 10 |
| 4 RTX-A-MMM | 1/2" | 10 |
| 5 RTX-A-MMM | 3/4" | 10 |
| 6 RTX-A-MMM | 1" | 10 |

Cilindrico - *Parallel*
AISI 316 L

RTX-A-FFF



| COD | | 🛒 |
|-------------|------|----|
| 1 RTX-A-FFF | 1/8" | 10 |
| 2 RTX-A-FFF | 1/4" | 10 |
| 3 RTX-A-FFF | 3/8" | 10 |
| 4 RTX-A-FFF | 1/2" | 10 |
| 5 RTX-A-FFF | 3/4" | 10 |
| 6 RTX-A-FFF | 1" | 10 |

AISI 316 L

RXX-A-4F



| COD | | 🛒 |
|------------|------|----|
| 1 RXX-A-4F | 1/8" | 10 |
| 2 RXX-A-4F | 1/4" | 10 |
| 3 RXX-A-4F | 3/8" | 10 |
| 4 RXX-A-4F | 1/2" | 10 |
| 5 RXX-A-4F | 3/4" | 10 |
| 6 RXX-A-4F | 1" | 10 |

AISI 316 L

RXX-A-4M



| COD | | 🛒 |
|------------|------|----|
| 1 RXX-A-4M | 1/8" | 10 |
| 2 RXX-A-4M | 1/4" | 10 |
| 3 RXX-A-4M | 3/8" | 10 |
| 4 RXX-A-4M | 1/2" | 10 |
| 5 RXX-A-4M | 3/4" | 10 |
| 6 RXX-A-4M | 1" | 10 |

Cilindrico - *Parallel*
AISI 316 L

TX-A-F



| COD | | 🛒 |
|----------|------|----|
| 1 TX-A-F | 1/8" | 10 |
| 2 TX-A-F | 1/4" | 10 |
| 3 TX-A-F | 3/8" | 10 |
| 4 TX-A-F | 1/2" | 10 |
| 5 TX-A-F | 3/4" | 10 |
| 6 TX-A-F | 1" | 10 |

AISI 316 L

TX-A-M



| COD | | 🛒 |
|----------|------|----|
| 1 TX-A-M | 1/8" | 10 |
| 2 TX-A-M | 1/4" | 10 |
| 3 TX-A-M | 3/8" | 10 |
| 4 TX-A-M | 1/2" | 10 |
| 5 TX-A-M | 3/4" | 10 |
| 6 TX-A-M | 1" | 10 |

Cilindrico - *Parallel*
AISI 316 L

RACCORDI RAPIDI INOX AISI 316 L - AISI 316 L STAINLESS STEEL PUSH-IN FITTINGS

RX-RDM



| COD | | | | | 🛒 |
|-----------|----|------|--|--|----|
| 1 RX-RDM | 4 | M5 | | | 10 |
| 2 RX-RDM | 4 | 1/8" | | | 10 |
| 3 RX-RDM | 6 | 1/8" | | | 10 |
| 4 RX-RDM | 6 | 1/4" | | | 10 |
| 5 RX-RDM | 8 | 1/8" | | | 10 |
| 6 RX-RDM | 8 | 1/4" | | | 10 |
| 7 RX-RDM | 10 | 1/4" | | | 10 |
| 8 RX-RDM | 10 | 3/8" | | | 10 |
| 9 RX-RDM | 12 | 3/8" | | | 10 |
| 10 RX-RDM | 12 | 1/2" | | | 10 |

Cilindrico + OR
Parallel + OR
AISI 316 L

RX-RDM-C



| COD | | | | | 🛒 |
|-------------|----|------|--|--|----|
| 1 RX-RDM-C | 4 | 1/8" | | | 10 |
| 2 RX-RDM-C | 4 | 1/4" | | | 10 |
| 3 RX-RDM-C | 6 | 1/8" | | | 10 |
| 4 RX-RDM-C | 6 | 1/4" | | | 10 |
| 5 RX-RDM-C | 8 | 1/8" | | | 10 |
| 6 RX-RDM-C | 8 | 1/4" | | | 10 |
| 7 RX-RDM-C | 10 | 1/4" | | | 10 |
| 8 RX-RDM-C | 10 | 3/8" | | | 10 |
| 9 RX-RDM-C | 12 | 3/8" | | | 10 |
| 10 RX-RDM-C | 12 | 1/2" | | | 10 |

Conico - Taper
AISI 316 L

RX-RG



| COD | | | | | 🛒 |
|---------|----|--|--|--|----|
| 1 RX-RG | 4 | | | | 10 |
| 2 RX-RG | 6 | | | | 10 |
| 3 RX-RG | 8 | | | | 10 |
| 4 RX-RG | 10 | | | | 10 |
| 5 RX-RG | 12 | | | | 10 |

AISI 316 L

RX-RG1-C



| COD | | | | | 🛒 |
|------------|---|------|--|--|----|
| 1 RX-RG1-C | 4 | 1/8" | | | 10 |
| 2 RX-RG1-C | 6 | 1/8" | | | 10 |
| 3 RX-RG1-C | 6 | 1/4" | | | 10 |
| 4 RX-RG1-C | 8 | 1/8" | | | 10 |
| 5 RX-RG1-C | 8 | 1/4" | | | 10 |

Conico - Taper
AISI 316 L

RX-RG1-G



| COD | | | | | 🛒 |
|-------------|----|------|--|--|----|
| 1 RX-RG1-G | 4 | M5 | | | 10 |
| 2 RX-RG1-G | 4 | 1/8" | | | 10 |
| 3 RX-RG1-G | 6 | 1/8" | | | 10 |
| 4 RX-RG1-G | 6 | 1/4" | | | 10 |
| 5 RX-RG1-G | 8 | 1/8" | | | 10 |
| 6 RX-RG1-G | 8 | 1/4" | | | 10 |
| 7 RX-RG1-G | 10 | 1/4" | | | 10 |
| 8 RX-RG1-G | 10 | 3/8" | | | 10 |
| 9 RX-RG1-G | 12 | 3/8" | | | 10 |
| 10 RX-RG1-G | 12 | 1/2" | | | 10 |

Cilindrico girevole + OR
Male swivel elbow
parallel + OR
AISI 316 L

RX-RG1-CG



| COD | | | | | 🛒 |
|-------------|----|------|--|--|----|
| 1 RX-RG1-CG | 4 | 1/8" | | | 10 |
| 2 RX-RG1-CG | 6 | 1/8" | | | 10 |
| 3 RX-RG1-CG | 6 | 1/4" | | | 10 |
| 4 RX-RG1-CG | 8 | 1/8" | | | 10 |
| 5 RX-RG1-CG | 8 | 1/4" | | | 10 |
| 6 RX-RG1-CG | 10 | 1/4" | | | 10 |
| 7 RX-RG1-CG | 10 | 3/8" | | | 10 |
| 8 RX-RG1-CG | 12 | 3/8" | | | 10 |
| 9 RX-RG1-CG | 12 | 1/2" | | | 10 |

Conico girevole
Male swivel elbow
taper
AISI 316 L

RX-RA



| COD | | | | | 🛒 |
|---------|---|----|--|--|----|
| 1 RX-RA | 4 | 6 | | | 10 |
| 2 RX-RA | 6 | 8 | | | 10 |
| 3 RX-RA | 8 | 10 | | | 10 |

AISI 316 L

RX-RL



| COD | | | | | 🛒 |
|---------|----|--|--|--|----|
| 1 RX-RL | 4 | | | | 10 |
| 2 RX-RL | 6 | | | | 10 |
| 3 RX-RL | 8 | | | | 10 |
| 4 RX-RL | 10 | | | | 10 |
| 5 RX-RL | 12 | | | | 10 |

AISI 316 L

RX-RT



| COD | | | | | 🛒 |
|---------|----|--|--|--|----|
| 1 RX-RT | 4 | | | | 10 |
| 2 RX-RT | 6 | | | | 10 |
| 3 RX-RT | 8 | | | | 10 |
| 4 RX-RT | 10 | | | | 10 |
| 5 RX-RT | 12 | | | | 10 |

AISI 316 L

RX-RT2-G



| COD | | | | | 🛒 |
|------------|----|------|--|--|----|
| 1 RX-RT2-G | 4 | M5 | | | 10 |
| 2 RX-RT2-G | 4 | 1/8" | | | 10 |
| 3 RX-RT2-G | 6 | 1/8" | | | 10 |
| 4 RX-RT2-G | 6 | 1/4" | | | 10 |
| 5 RX-RT2-G | 8 | 1/8" | | | 10 |
| 6 RX-RT2-G | 8 | 1/4" | | | 10 |
| 7 RX-RT2-G | 10 | 1/4" | | | 10 |
| 8 RX-RT2-G | 10 | 3/8" | | | 10 |

Cilindrico girevole + OR
Swivel tee-central male
parallel + OR
AISI 316 L

RX-RT2-CG



Conico girevole
Swivel tee-central male
Taper
AISI 316 L

| COD | | | | | |
|-----|-----------|----|------|----|--|
| 1 | RX-RT2-CG | 4 | 1/8" | 10 | |
| 2 | RX-RT2-CG | 6 | 1/8" | 10 | |
| 3 | RX-RT2-CG | 6 | 1/4" | 10 | |
| 4 | RX-RT2-CG | 8 | 1/8" | 10 | |
| 5 | RX-RT2-CG | 8 | 1/4" | 10 | |
| 6 | RX-RT2-CG | 10 | 1/4" | 10 | |
| 7 | RX-RT2-CG | 10 | 3/8" | 10 | |

RX-AS-C1



Cilindrico - Parallel
AISI 316 L

| COD | | | | | |
|-----|----------|----|------|----|--|
| 1 | RX-AS-C1 | 4 | M5 | 10 | |
| 2 | RX-AS-C1 | 4 | 1/8" | 10 | |
| 3 | RX-AS-C1 | 6 | M5 | 10 | |
| 4 | RX-AS-C1 | 6 | 1/8" | 10 | |
| 5 | RX-AS-C1 | 6 | 1/4" | 10 | |
| 6 | RX-AS-C1 | 8 | 1/8" | 10 | |
| 7 | RX-AS-C1 | 8 | 1/4" | 10 | |
| 8 | RX-AS-C1 | 8 | 3/8" | 10 | |
| 9 | RX-AS-C1 | 10 | 3/8" | 10 | |
| 10 | RX-AS-C1 | 10 | 1/2" | 10 | |

RX-RP



AISI 316 L

| COD | | | | | |
|-----|-------|----|-------|----|--|
| 1 | RX-RP | 4 | M12x1 | 10 | |
| 2 | RX-RP | 6 | M14x1 | 10 | |
| 3 | RX-RP | 8 | M16x1 | 10 | |
| 4 | RX-RP | 10 | M18x1 | 10 | |
| 5 | RX-RP | 12 | M20x1 | 10 | |

RX-RPG



AISI 316 L

| COD | | | | | |
|-----|--------|----|--|----|--|
| 1 | RX-RPG | 4 | | 10 | |
| 2 | RX-RPG | 6 | | 10 | |
| 3 | RX-RPG | 8 | | 10 | |
| 4 | RX-RPG | 10 | | 10 | |
| 5 | RX-RPG | 12 | | 10 | |

RX-PLF



Femmina - Female
AISI 316

| COD | | | | | |
|-----|--------|----|------|----|--|
| 1 | RX-PLF | 4 | 1/8" | 10 | |
| 2 | RX-PLF | 6 | 1/8" | 10 | |
| 3 | RX-PLF | 6 | 1/4" | 10 | |
| 4 | RX-PLF | 8 | 1/8" | 10 | |
| 5 | RX-PLF | 8 | 1/4" | 10 | |
| 6 | RX-PLF | 10 | 1/4" | 10 | |
| 7 | RX-PLF | 10 | 1/2" | 10 | |
| 8 | RX-PLF | 12 | 1/4" | 10 | |
| 9 | RX-PLF | 12 | 1/2" | 10 | |

RX-PST



Cilindrico - Parallel
AISI 316 L

| COD | | | | | |
|-----|--------|----|------|----|--|
| 1 | RX-PST | 4 | 1/8" | 10 | |
| 2 | RX-PST | 6 | 1/8" | 10 | |
| 3 | RX-PST | 6 | 1/4" | 10 | |
| 4 | RX-PST | 8 | 1/8" | 10 | |
| 5 | RX-PST | 8 | 1/4" | 10 | |
| 6 | RX-PST | 10 | 1/4" | 10 | |
| 7 | RX-PST | 10 | 1/2" | 10 | |
| 8 | RX-PST | 12 | 1/4" | 10 | |
| 9 | RX-PST | 12 | 1/2" | 10 | |

RX-POC



Cilindrico + OR
Parallel + OR
AISI 316 L

| COD | | | | | |
|-----|--------|----|------|----|--|
| 1 | RX-POC | 4 | M5 | 10 | |
| 2 | RX-POC | 4 | 1/8" | 10 | |
| 3 | RX-POC | 6 | 1/8" | 10 | |
| 4 | RX-POC | 6 | 1/4" | 10 | |
| 5 | RX-POC | 8 | 1/8" | 10 | |
| 6 | RX-POC | 8 | 1/4" | 10 | |
| 7 | RX-POC | 10 | 1/4" | 10 | |
| 8 | RX-POC | 10 | 1/2" | 10 | |
| 9 | RX-POC | 12 | 1/2" | 10 | |

RX-YTT



Cilindrico - Parallel
AISI 316 L

| COD | | | | | |
|-----|--------|----|------|----|--|
| 1 | RX-YTT | 4 | 1/8" | 10 | |
| 2 | RX-YTT | 6 | 1/8" | 10 | |
| 3 | RX-YTT | 6 | 1/4" | 10 | |
| 4 | RX-YTT | 8 | 1/8" | 10 | |
| 5 | RX-YTT | 8 | 3/8" | 10 | |
| 6 | RX-YTT | 8 | 1/2" | 10 | |
| 7 | RX-YTT | 10 | 1/4" | 10 | |
| 8 | RX-YTT | 10 | 3/8" | 10 | |
| 9 | RX-YTT | 10 | 1/2" | 10 | |

RX-4T



AISI 316 L

| COD | | | | | |
|-----|-------|----|--|----|--|
| 1 | RX-4T | 4 | | 10 | |
| 2 | RX-4T | 6 | | 10 | |
| 3 | RX-4T | 8 | | 10 | |
| 4 | RX-4T | 10 | | 10 | |

RX-5T



AISI 316 L

| COD | | | | | |
|-----|-------|----|--|----|--|
| 1 | RX-5T | 4 | | 10 | |
| 2 | RX-5T | 6 | | 10 | |
| 3 | RX-5T | 8 | | 10 | |
| 4 | RX-5T | 10 | | 10 | |
| 5 | RX-5T | 12 | | 10 | |

RACCORDI RAPIDI INOX AISI 316 L - AISI 316 L STAINLESS STEEL PUSH-IN FITTINGS

RX-FRP



COD

| | | | |
|----------|----|------|----|
| 1 RX-FRP | 4 | M5 | 10 |
| 2 RX-FRP | 4 | 1/8" | 10 |
| 3 RX-FRP | 6 | M5 | 10 |
| 4 RX-FRP | 6 | 1/8" | 10 |
| 5 RX-FRP | 8 | 1/8" | 10 |
| 6 RX-FRP | 8 | 1/4" | 10 |
| 7 RX-FRP | 10 | 3/8" | 10 |
| 8 RX-FRP | 10 | 1/2" | 10 |
| 9 RX-FRP | 12 | 1/2" | 10 |

AISI 316 L

RX-RTT



COD

| | | | |
|----------|----|----|----|
| 1 RX-RTT | 6 | 4 | 10 |
| 2 RX-RTT | 8 | 4 | 10 |
| 3 RX-RTT | 8 | 6 | 10 |
| 4 RX-RTT | 10 | 6 | 10 |
| 5 RX-RTT | 10 | 8 | 10 |
| 6 RX-RTT | 12 | 8 | 10 |
| 7 RX-RTT | 12 | 10 | 10 |

AISI 316 L

RX-SC



COD

| | | | |
|---------|----|------|----|
| 1 RX-SC | 4 | M5 | 10 |
| 2 RX-SC | 4 | 1/8" | 10 |
| 3 RX-SC | 6 | 1/8" | 10 |
| 4 RX-SC | 6 | 1/4" | 10 |
| 5 RX-SC | 8 | 1/8" | 10 |
| 6 RX-SC | 8 | 1/4" | 10 |
| 7 RX-SC | 10 | 1/4" | 10 |
| 8 RX-SC | 10 | 1/2" | 10 |
| 9 RX-SC | 12 | 1/2" | 10 |

Cilindrico - *Parallel*
AISI 316 L

RX-SCI



COD

| | | | |
|----------|----|---|----|
| 1 RX-SCI | 6 | 4 | 10 |
| 2 RX-SCI | 8 | 4 | 10 |
| 3 RX-SCI | 8 | 6 | 10 |
| 4 RX-SCI | 10 | 6 | 10 |
| 5 RX-SCI | 10 | 8 | 10 |

AISI 316 L

RGS-X

| COD | A | B | 🛒 | |
|---------|------|----|----|----|
| 1 RGS-X | 1/8" | 35 | 25 | 10 |
| 2 RGS-X | 1/4" | 40 | 28 | 10 |
| 3 RGS-X | 3/8" | 45 | 28 | 10 |
| 4 RGS-X | 1/2" | 56 | 42 | 10 |



Raccordo a sfera orientabile per ugelli
Materiale: Acciaio Inox **AISI 316 L**
Angolo 45° in ogni direzione
Adjustable ball fitting for nozzles
Material: **AISI 316 L Stainless Steel**
45° angle in any direction

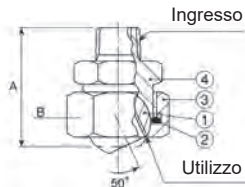

Ingresso

Utilizzo

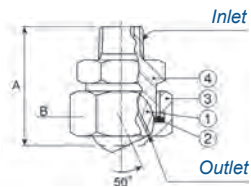

Inlet

Outlet

① sfera ball ② o-ring o-ring ③ corpo body ④ adattatore adapter

RX-RYTTT



COD

| | | | | |
|------------|----|----|----|----|
| 1 RX-RYTTT | 6 | 4 | 4 | 10 |
| 2 RX-RYTTT | 8 | 4 | 4 | 10 |
| 3 RX-RYTTT | 8 | 6 | 6 | 10 |
| 4 RX-RYTTT | 10 | 6 | 6 | 10 |
| 5 RX-RYTTT | 10 | 8 | 8 | 10 |
| 6 RX-RYTTT | 12 | 6 | 6 | 10 |
| 7 RX-RYTTT | 12 | 8 | 8 | 10 |
| 8 RX-RYTTT | 12 | 10 | 10 | 10 |
| 9 RX-RYTTT | 16 | 12 | 12 | 10 |

AISI 316 L

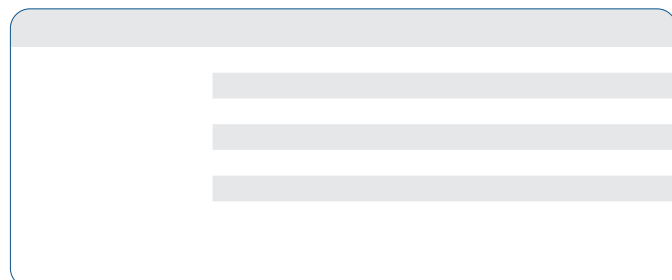
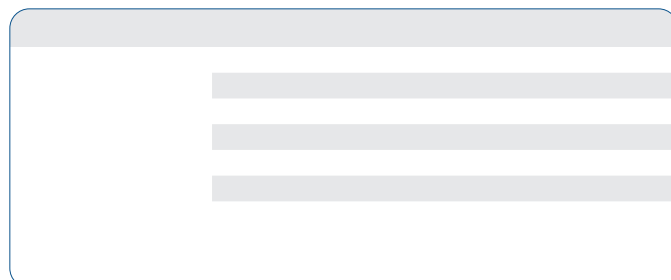

RDMX-C



| COD | | 1/2" |
|-------------|-----------|------|
| 1 RDMX-C | 4 - 1/8" | 10 |
| 2 RDMX-C | 4 - 1/4" | 10 |
| 3 RDMX-C | 6 - 1/8" | 10 |
| 4 RDMX-C | 6 - 1/4" | 10 |
| 4.1 RDMX-C | 6 - 3/8" | 10 |
| 5 RDMX-C | 6 - 3/8" | 10 |
| 6 RDMX-C | 8 - 1/8" | 10 |
| 7 RDMX-C | 8 - 1/4" | 10 |
| 8 RDMX-C | 8 - 3/8" | 10 |
| 8.1 RDMX-C | 10 - 1/8" | 10 |
| 9 RDMX-C | 8 - 1/2" | 10 |
| 10 RDMX-C | 10 - 1/4" | 10 |
| 10.1 RDMX-C | 10 - 1/2" | 10 |
| 11 RDMX-C | 10 - 3/8" | 10 |
| 12 RDMX-C | 10 - 1/2" | 10 |
| 13 RDMX-C | 12 - 1/4" | 10 |
| 14 RDMX-C | 12 - 3/8" | 10 |
| 15 RDMX-C | 12 - 1/2" | 10 |
| 16 RDMX-C | 14 - 1/4" | 10 |
| 17 RDMX-C | 14 - 3/8" | 10 |
| 18 RDMX-C | 14 - 1/2" | 10 |

Conico -Taper
AISI 316 L

RG-1X-C



| COD | | 1/2" |
|------------|-----------|------|
| 1 RG-1X-C | 4 - 1/8" | 10 |
| 2 RG-1X-C | 4 - 1/4" | 10 |
| 3 RG-1X-C | 6 - 1/8" | 10 |
| 4 RG-1X-C | 6 - 1/4" | 10 |
| 5 RG-1X-C | 6 - 3/8" | 10 |
| 6 RG-1X-C | 8 - 1/8" | 10 |
| 7 RG-1X-C | 8 - 1/4" | 10 |
| 8 RG-1X-C | 8 - 3/8" | 10 |
| 9 RG-1X-C | 8 - 1/2" | 10 |
| 10 RG-1X-C | 10 - 1/4" | 10 |
| 11 RG-1X-C | 10 - 3/8" | 10 |
| 12 RG-1X-C | 10 - 1/2" | 10 |
| 13 RG-1X-C | 12 - 1/4" | 10 |
| 14 RG-1X-C | 12 - 3/8" | 10 |
| 15 RG-1X-C | 12 - 1/2" | 10 |
| 16 RG-1X-C | 14 - 1/4" | 10 |
| 17 RG-1X-C | 14 - 3/8" | 10 |
| 18 RG-1X-C | 14 - 1/2" | 10 |

Conico -Taper
AISI 316 L

RG-2X-C



| COD | | 1/2" |
|------------|-----------|------|
| 1 RG-2X-C | 4 - 1/8" | 10 |
| 2 RG-2X-C | 4 - 1/4" | 10 |
| 3 RG-2X-C | 6 - 1/8" | 10 |
| 4 RG-2X-C | 6 - 1/4" | 10 |
| 5 RG-2X-C | 6 - 3/8" | 10 |
| 6 RG-2X-C | 8 - 1/8" | 10 |
| 7 RG-2X-C | 8 - 1/4" | 10 |
| 8 RG-2X-C | 8 - 3/8" | 10 |
| 9 RG-2X-C | 8 - 1/2" | 10 |
| 10 RG-2X-C | 10 - 1/4" | 10 |
| 11 RG-2X-C | 10 - 3/8" | 10 |
| 12 RG-2X-C | 10 - 1/2" | 10 |
| 13 RG-2X-C | 12 - 1/4" | 10 |
| 14 RG-2X-C | 12 - 3/8" | 10 |
| 15 RG-2X-C | 12 - 1/2" | 10 |
| 16 RG-2X-C | 14 - 1/4" | 10 |
| 17 RG-2X-C | 14 - 3/8" | 10 |
| 18 RG-2X-C | 14 - 1/2" | 10 |

Conico -Taper
AISI 316 L

RDX



| COD | | 1/2" |
|-------|----|------|
| 1 RDX | 4 | 10 |
| 2 RDX | 6 | 10 |
| 3 RDX | 8 | 10 |
| 4 RDX | 10 | 10 |
| 5 RDX | 12 | 10 |
| 6 RDX | 14 | 10 |

AISI 316 L

RGX



| COD | | 1/2" |
|-------|----|------|
| 1 RGX | 4 | 10 |
| 2 RGX | 6 | 10 |
| 3 RGX | 8 | 10 |
| 4 RGX | 10 | 10 |
| 5 RGX | 12 | 10 |
| 6 RGX | 14 | 10 |

AISI 316 L

RTX



| COD | | 1/2" |
|-------|----|------|
| 1 RTX | 4 | 10 |
| 2 RTX | 6 | 10 |
| 3 RTX | 8 | 10 |
| 4 RTX | 10 | 10 |
| 5 RTX | 12 | 10 |
| 6 RTX | 14 | 10 |

AISI 316 L

RG-3X



| COD | | 1/2" |
|---------|-----------|------|
| 1 RG-3X | 4 - 1/8" | 10 |
| 2 RG-3X | 4 - 1/4" | 10 |
| 3 RG-3X | 6 - 1/4" | 10 |
| 4 RG-3X | 8 - 1/4" | 10 |
| 5 RG-3X | 10 - 3/8" | 10 |
| 6 RG-3X | 12 - 1/2" | 10 |
| 7 RG-3X | 14 - 1/2" | 10 |

Cilindrico girevole+OR
Parallel swivel+OR
AISI 316 L

RT-1X-C



| COD | | 1/2" |
|-------------|-----------|------|
| 1 RT-1X-C | 4 - 1/8" | 10 |
| 2 RT-1X-C | 4 - 1/4" | 10 |
| 3 RT-1X-C | 6 - 1/4" | 10 |
| 4 RT-1X-C | 6 - 3/8" | 10 |
| 5 RT-1X-C | 8 - 1/4" | 10 |
| 6 RT-1X-C | 8 - 3/8" | 10 |
| 7 RT-1X-C | 10 - 1/4" | 10 |
| 7.1 RT-1X-C | 8 - 3/8" | 10 |
| 8 RT-1X-C | 10 - 3/8" | 10 |
| 9 RT-1X-C | 12 - 3/8" | 10 |
| 10 RT-1X-C | 12 - 1/2" | 10 |
| 11 RT-1X-C | 14 - 1/2" | 10 |

Conico -Taper
AISI 316 L

RPX



| COD | | 1/2" |
|-------|----|------|
| 1 RPX | 4 | 10 |
| 2 RPX | 6 | 10 |
| 3 RPX | 8 | 10 |
| 4 RPX | 10 | 10 |
| 5 RPX | 12 | 10 |
| 6 RPX | 14 | 10 |

AISI 316 L



PUSH-IN FITTINGS

| | | | | | |
|---|-----------|----|--|-------|----|
|  | EPC | 95 |  | EPW | 96 |
|  | EPCF | 95 |  | ESA | 97 |
|  | EPL | 95 |  | EPZA | 97 |
|  | EPLF | 95 |  | EPGJ | 97 |
|  | EPLL | 95 |  | EPP | 97 |
|  | EPHF | 95 |  | EPV | 97 |
|  | ESL/ESL-B | 95 |  | EPM | 97 |
|  | EPB | 96 |  | PC-C | 97 |
|  | EPD | 96 |  | PL-C | 97 |
|  | EPX | 96 |  | PT-C | 97 |
|  | EPG | 96 |  | PST-C | 97 |
|  | EPU | 96 |  | PUC-C | 97 |
|  | EPE | 96 |  | PUL-C | 97 |
|  | EPEG | 96 |  | PUT-C | 97 |
|  | EPY | 96 | | | |

EPC



| COD | | 🛒 |
|--------|------|----|
| 4 EPC | M5 | 10 |
| 4 EPC | 1/8" | 10 |
| 4 EPC | 1/4" | 10 |
| 6 EPC | M5 | 10 |
| 6 EPC | 1/8" | 10 |
| 6 EPC | 1/4" | 10 |
| 6 EPC | 3/8" | 10 |
| 8 EPC | 1/8" | 10 |
| 8 EPC | 1/4" | 10 |
| 8 EPC | 3/8" | 10 |
| 8 EPC | 1/2" | 10 |
| 10 EPC | 1/8" | 10 |
| 10 EPC | 1/4" | 10 |
| 10 EPC | 3/8" | 10 |
| 10 EPC | 1/2" | 10 |
| 12 EPC | 1/4" | 10 |
| 12 EPC | 3/8" | 10 |
| 16 EPC | 3/8" | 10 |
| 16 EPC | 1/2" | 10 |

Conico Teflonato
Cilindrico OR + 10%
Taper with teflon
Parallel + OR (+ 10%)

EPCF



| COD | | 🛒 |
|---------|------|----|
| 4 EPCF | 1/8" | 10 |
| 4 EPCF | 1/4" | 10 |
| 6 EPCF | 1/8" | 10 |
| 6 EPCF | 1/4" | 10 |
| 6 EPCF | 3/8" | 10 |
| 8 EPCF | 1/8" | 10 |
| 8 EPCF | 1/4" | 10 |
| 8 EPCF | 3/8" | 10 |
| 8 EPCF | 1/2" | 10 |
| 10 EPCF | 1/8" | 10 |
| 10 EPCF | 1/4" | 10 |
| 10 EPCF | 3/8" | 10 |
| 10 EPCF | 1/2" | 10 |
| 12 EPCF | 1/4" | 10 |
| 12 EPCF | 3/8" | 10 |

Femmina
Female

EPL



| COD | | 🛒 |
|--------|------|----|
| 4 EPL | M5 | 10 |
| 4 EPL | 1/8" | 10 |
| 4 EPL | 1/4" | 10 |
| 6 EPL | M5 | 10 |
| 6 EPL | 1/8" | 10 |
| 6 EPL | 1/4" | 10 |
| 6 EPL | 3/8" | 10 |
| 8 EPL | 1/8" | 10 |
| 8 EPL | 1/4" | 10 |
| 8 EPL | 3/8" | 10 |
| 8 EPL | 1/2" | 10 |
| 10 EPL | 1/4" | 10 |
| 10 EPL | 3/8" | 10 |
| 10 EPL | 1/2" | 10 |
| 12 EPL | 1/2" | 10 |
| 16 EPL | 1/2" | 10 |

Conico Teflonato
Cilindrico OR + 10%
Taper with teflon
Parallel + OR (+ 10%)

EPLF



| COD | | 🛒 |
|--------|------|----|
| 4 EPLF | 1/8" | 10 |
| 4 EPLF | 1/4" | 10 |
| 6 EPLF | 1/8" | 10 |
| 6 EPLF | 1/4" | 10 |
| 6 EPLF | 3/8" | 10 |
| 8 EPLF | 1/8" | 10 |
| 8 EPLF | 1/4" | 10 |

Femmina
Female

EPLL



| COD | | 🛒 |
|---------|------|----|
| 4 EPLL | 1/8" | 10 |
| 6 EPLL | 1/8" | 10 |
| 6 EPLL | 1/4" | 10 |
| 8 EPLL | 1/8" | 10 |
| 8 EPLL | 1/4" | 10 |
| 10 EPLL | 1/4" | 10 |
| 10 EPLL | 3/8" | 10 |
| 12 EPLL | 3/8" | 10 |

Conico Teflonato
Cilindrico OR + 10%
Taper with teflon
Parallel + OR (+ 10%)

EPHF



| COD | | 🛒 |
|---------|------|----|
| 4 EPHF | 1/8" | 10 |
| 6 EPHF | 1/8" | 10 |
| 6 EPHF | 1/4" | 10 |
| 8 EPHF | 1/8" | 10 |
| 8 EPHF | 1/4" | 10 |
| 8 EPHF | 3/8" | 10 |
| 10 EPHF | 1/4" | 10 |
| 10 EPHF | 3/8" | 10 |
| 12 EPHF | 1/4" | 10 |
| 12 EPHF | 3/8" | 10 |

Conico Teflonato
Cilindrico OR + 10%
Taper with teflon
Parallel + OR (+ 10%)

ESL/ESL-B



| COD | | 🛒 |
|--------|------|----|
| 4 ESL | M5 | 10 |
| 4 ESL | 1/8" | 10 |
| 6 ESL | 1/8" | 10 |
| 6 ESL | 1/4" | 10 |
| 8 ESL | 1/8" | 10 |
| 8 ESL | 1/4" | 10 |
| 8 ESL | 3/8" | 10 |
| 10 ESL | 1/4" | 10 |
| 10 ESL | 3/8" | 10 |
| 10 ESL | 1/2" | 10 |
| 12 ESL | 3/8" | 10 |
| 12 ESL | 1/2" | 10 |

Conico Teflonato
Cilindrico OR + 10%
ESL: per cilindro
ESL-B: per valvola
Taper with teflon
Parallel + OR (+ 10%)
ESL Type: for cylinders
ESL-B Type: for valves

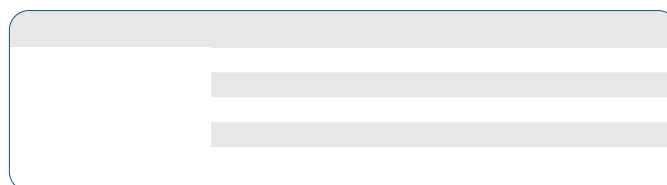
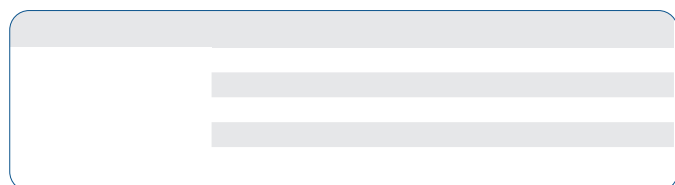

RACCORDI RAPIDI TECNOPOLIMERO - *PUSH-IN PLASTIC FITTINGS*

EPB



| COD | | 🛒 |
|--------|------|----|
| 4 EPB | M5 | 10 |
| 4 EPB | 1/8" | 10 |
| 4 EPB | 1/4" | 10 |
| 6 EPB | M5 | 10 |
| 6 EPB | M6 | 10 |
| 6 EPB | 1/8" | 10 |
| 6 EPB | 1/4" | 10 |
| 8 EPB | 1/8" | 10 |
| 8 EPB | 1/4" | 10 |
| 8 EPB | 3/8" | 10 |
| 8 EPB | 1/2" | 10 |
| 10 EPB | 1/4" | 10 |
| 10 EPB | 3/8" | 10 |
| 10 EPB | 1/2" | 10 |
| 12 EPB | 1/4" | 10 |
| 12 EPB | 3/8" | 10 |
| 12 EPB | 1/2" | 10 |
| 16 EPB | 1/2" | 10 |

Conico Teflonato
Cilindrico OR + 10%
Taper with teflon
Parallel + OR (+ 10%)

EPD



| COD | | 🛒 |
|--------|------|----|
| 4 EPD | 1/8" | 10 |
| 4 EPD | 1/4" | 10 |
| 6 EPD | 1/8" | 10 |
| 6 EPD | 1/4" | 10 |
| 8 EPD | 1/8" | 10 |
| 8 EPD | 1/4" | 10 |
| 8 EPD | 3/8" | 10 |
| 8 EPD | 1/2" | 10 |
| 10 EPD | 1/4" | 10 |
| 10 EPD | 3/8" | 10 |
| 10 EPD | 1/2" | 10 |
| 12 EPD | 1/4" | 10 |
| 12 EPD | 3/8" | 10 |
| 12 EPD | 1/2" | 10 |
| 16 EPD | 1/2" | 10 |

Conico Teflonato
Cilindrico OR + 10%
Taper with teflon
Parallel + OR (+ 10%)

EPX



| COD | | 🛒 |
|--------|------|----|
| 4 EPX | M5 | 10 |
| 4 EPX | M6 | 10 |
| 4 EPX | 1/8" | 10 |
| 4 EPX | 1/4" | 10 |
| 6 EPX | M5 | 10 |
| 6 EPX | M6 | 10 |
| 6 EPX | 1/8" | 10 |
| 6 EPX | 1/4" | 10 |
| 6 EPX | 3/8" | 10 |
| 8 EPX | 1/8" | 10 |
| 8 EPX | 1/4" | 10 |
| 8 EPX | 3/8" | 10 |
| 8 EPX | 1/2" | 10 |
| 10 EPX | 1/4" | 10 |
| 10 EPX | 3/8" | 10 |
| 10 EPX | 1/2" | 10 |
| 12 EPX | 1/4" | 10 |
| 12 EPX | 3/8" | 10 |
| 12 EPX | 1/2" | 10 |
| 16 EPX | 3/8" | 10 |
| 16 EPX | 1/2" | 10 |

Conico Teflonato
Cilindrico OR + 10%
Taper with teflon
Parallel + OR (+ 10%)

EPG



| COD | | 🛒 |
|-------|-----|----|
| 6-4 | EPG | 10 |
| 8-6 | EPG | 10 |
| 10-8 | EPG | 10 |
| 12-10 | EPG | 10 |

EPU



| COD | | 🛒 |
|--------|--|----|
| 4 EPU | | 10 |
| 6 EPU | | 10 |
| 8 EPU | | 10 |
| 10 EPU | | 10 |
| 12 EPU | | 10 |
| 14 EPU | | 10 |
| 16 EPU | | 10 |

EPE



| COD | | 🛒 |
|--------|--|----|
| 4 EPE | | 10 |
| 6 EPE | | 10 |
| 8 EPE | | 10 |
| 10 EPE | | 10 |
| 12 EPE | | 10 |
| 14 EPE | | 10 |
| 16 EPE | | 10 |

EPEG



| COD | | 🛒 |
|-------|------|----|
| 6-4 | EPEG | 10 |
| 8-6 | EPEG | 10 |
| 10-8 | EPEG | 10 |
| 12-10 | EPEG | 10 |

Ø centrale ridotto
Ø central small

EPY



| COD | | 🛒 |
|--------|--|----|
| 4 EPY | | 10 |
| 6 EPY | | 10 |
| 8 EPY | | 10 |
| 10 EPY | | 10 |
| 12 EPY | | 10 |

EPW



| COD | | 🛒 |
|-------|-----|----|
| 6-4 | EPW | 10 |
| 8-6 | EPW | 10 |
| 10-8 | EPW | 10 |
| 12-10 | EPW | 10 |

RACCORDI RAPIDI TECNOPOLIMERO - *PUSH-IN PLASTIC FITTINGS*

ESA



| COD | | 🛒 |
|--------|--|----|
| 4 ESA | | 10 |
| 6 ESA | | 10 |
| 8 ESA | | 10 |
| 10 ESA | | 10 |
| 12 ESA | | 10 |

EPZA



| COD | | 🛒 |
|---------|--|----|
| 4 EPZA | | 10 |
| 6 EPZA | | 10 |
| 8 EPZA | | 10 |
| 10 EPZA | | 10 |
| 12 EPZA | | 10 |

EPGJ



| COD | | 🛒 |
|------------|--|----|
| 6-4 EPGJ | | 10 |
| 8-4 EPGJ | | 10 |
| 8-6 EPGJ | | 10 |
| 10-6 EPGJ | | 10 |
| 10-8 EPGJ | | 10 |
| 12-8 EPGJ | | 10 |
| 12-10 EPGJ | | 10 |

EPP



Tappo - *Plug*

| COD | | 🛒 |
|--------|--|----|
| 4 EPP | | 10 |
| 6 EPP | | 10 |
| 8 EPP | | 10 |
| 10 EPP | | 10 |
| 12 EPP | | 10 |

EPV



| COD | | 🛒 |
|--------|----|----|
| 4 EPV | 4 | 10 |
| 5 EPV | 5 | 10 |
| 6 EPV | 6 | 10 |
| 8 EPV | 8 | 10 |
| 10 EPV | 10 | 10 |
| 12 EPV | 12 | 10 |
| 14 EPV | 14 | 10 |
| 16 EPV | 16 | 10 |

EPM



Passaparete
Bulkhead

| COD | | 🛒 |
|--------|--|----|
| 4 EPM | | 10 |
| 6 EPM | | 10 |
| 8 EPM | | 10 |
| 10 EPM | | 10 |
| 12 EPM | | 10 |
| 16 EPM | | 10 |

COMPACT FITTINGS - *COMPACT FITTINGS*

PC-C



Cilindrico + OR
Parallel + OR

| COD | | 🛒 |
|--------|----------|----|
| 1 PC-C | Ø 3 - M3 | 10 |
| 2 PC-C | Ø 3 - M5 | 10 |
| 3 PC-C | Ø 3 - M6 | 10 |
| 4 PC-C | Ø 4 - M3 | 10 |
| 5 PC-C | Ø 4 - M5 | 10 |
| 6 PC-C | Ø 4 - M6 | 10 |

PL-C



Cilindrico + OR
Parallel + OR

| COD | | 🛒 |
|--------|----------|----|
| 1 PL-C | Ø 3 - M3 | 10 |
| 2 PL-C | Ø 3 - M5 | 10 |
| 3 PL-C | Ø 3 - M6 | 10 |
| 4 PL-C | Ø 4 - M3 | 10 |
| 5 PL-C | Ø 4 - M5 | 10 |
| 6 PL-C | Ø 4 - M6 | 10 |

PT-C



Cilindrico + OR
Parallel + OR

| COD | | 🛒 |
|--------|----------|----|
| 1 PT-C | Ø 3 - M3 | 10 |
| 2 PT-C | Ø 3 - M5 | 10 |
| 3 PT-C | Ø 3 - M6 | 10 |
| 4 PT-C | Ø 4 - M3 | 10 |
| 5 PT-C | Ø 4 - M5 | 10 |
| 6 PT-C | Ø 4 - M6 | 10 |

PST-C



Cilindrico + OR
Parallel + OR

| COD | | 🛒 |
|---------|----------|----|
| 1 PST-C | Ø 3 - M3 | 10 |
| 2 PST-C | Ø 3 - M5 | 10 |
| 3 PST-C | Ø 3 - M6 | 10 |
| 4 PST-C | Ø 4 - M3 | 10 |
| 5 PST-C | Ø 4 - M5 | 10 |
| 6 PST-C | Ø 4 - M6 | 10 |

PUC-C



| COD | | 🛒 |
|---------|-----|----|
| 1 PUC-C | Ø 3 | 10 |
| 2 PUC-C | Ø 4 | 10 |
| 3 PUC-C | Ø 6 | 10 |

PUL-C



| COD | | 🛒 |
|---------|-----|----|
| 1 PUL-C | Ø 3 | 10 |
| 2 PUL-C | Ø 4 | 10 |
| 3 PUL-C | Ø 6 | 10 |

PUT-C



| COD | | 🛒 |
|---------|-----|----|
| 1 PUT-C | Ø 3 | 10 |
| 2 PUT-C | Ø 4 | 10 |
| 3 PUT-C | Ø 6 | 10 |

| COD | | 🛒 |
|-----|--|---|
| | | |
| | | |
| | | |

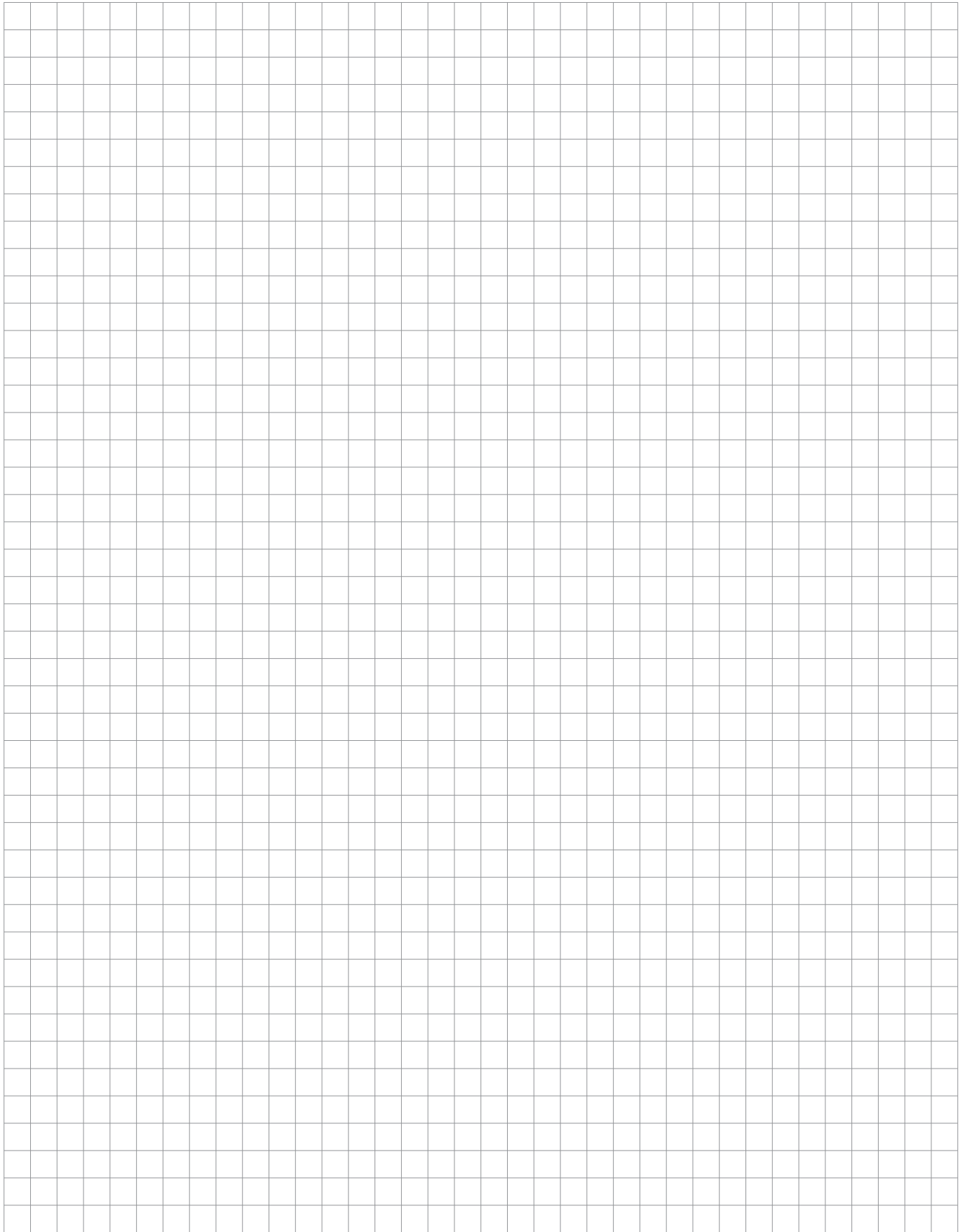



HOSE FITTINGS

RACCORDI PORTAGOMMA IN NYLON - NYLON HOSE FITTINGS

| | | | | | |
|---|----------|-----|--|---------|-----|
|  | RPN-CDFF | 101 |  | RPN-Y | 102 |
|  | RPN-DFM | 101 |  | RPP-DFM | 103 |
|  | RPN-LFM | 101 |  | RPP-LFM | 103 |
|  | RPN-TFM | 101 |  | RPP-TFM | 103 |
|  | RPN-L | 102 |  | RPP-FF | 103 |
|  | RPN-LL | 102 |  | RPP-T | 103 |
|  | RPN-D | 102 |  | GG-FF | 103 |
|  | RPN-DD | 102 |  | RPP-L | 103 |
|  | RPN-T | 102 |  | RPP-LL | 103 |
|  | RPN-DFM | 102 |  | RPP-D | 103 |
|  | RPN-TTT | 102 |  | RPP-DD | 103 |

RPN-CDFF



| COD | Ø | 🛒 |
|-------------|---------|----|
| 1 RPN-CDFF | 1/8"- 5 | 25 |
| 2 RPN-CDFF | 1/4"- 5 | 25 |
| 3 RPN-CDFF | 3/8"- 5 | 25 |
| 4 RPN-CDFF | 1/2"- 5 | 25 |
| 5 RPN-CDFF | 1/8"- 6 | 25 |
| 6 RPN-CDFF | 1/4"- 6 | 25 |
| 7 RPN-CDFF | 3/8"- 6 | 25 |
| 8 RPN-CDFF | 1/2"- 6 | 25 |
| 9 RPN-CDFF | 1/8"- 8 | 25 |
| 10 RPN-CDFF | 3/8"- 8 | 25 |
| 11 RPN-CDFF | 1/2"- 8 | 25 |
| 12 RPN-CDFF | 1/4"-10 | 25 |
| 13 RPN-CDFF | 3/8"-10 | 25 |
| 14 RPN-CDFF | 1/2"-10 | 25 |
| 15 RPN-CDFF | 1/4"-12 | 25 |
| 16 RPN-CDFF | 3/8"-12 | 25 |
| 17 RPN-CDFF | 1/2"-12 | 25 |
| 18 RPN-CDFF | 3/8"-14 | 25 |
| 19 RPN-CDFF | 1/2"-14 | 25 |
| 20 RPN-CDFF | 1/2"-16 | 25 |
| 21 RPN-CDFF | 1/2"-19 | 25 |

RPN-DFM



| COD | Ø | 🛒 |
|------------|---------|----|
| 1 RPN-DFM | 1/8"- 4 | 50 |
| 2 RPN-DFM | 1/4"- 4 | 50 |
| 3 RPN-DFM | 1/8"- 5 | 50 |
| 4 RPN-DFM | 1/4"- 5 | 50 |
| 5 RPN-DFM | 1/2"- 5 | 25 |
| 6 RPN-DFM | 1/8"- 6 | 50 |
| 7 RPN-DFM | 1/4"- 6 | 50 |
| 8 RPN-DFM | 3/8"- 6 | 50 |
| 9 RPN-DFM | 1/2"- 6 | 50 |
| 10 RPN-DFM | 3/4"- 6 | 25 |
| 11 RPN-DFM | 1/8"- 8 | 50 |
| 12 RPN-DFM | 1/4"- 8 | 50 |
| 13 RPN-DFM | 3/8"- 8 | 50 |
| 14 RPN-DFM | 1/2"- 8 | 50 |
| 15 RPN-DFM | 3/4"- 8 | 25 |
| 16 RPN-DFM | 1/4"-10 | 50 |
| 17 RPN-DFM | 3/8"-10 | 50 |
| 18 RPN-DFM | 1/2"-10 | 50 |
| 19 RPN-DFM | 3/4"-10 | 25 |
| 20 RPN-DFM | 1/4"-12 | 50 |
| 21 RPN-DFM | 3/8"-12 | 50 |
| 22 RPN-DFM | 1/2"-12 | 50 |
| 23 RPN-DFM | 3/4"-12 | 25 |
| 24 RPN-DFM | 3/8"-14 | 50 |
| 25 RPN-DFM | 1/2"-14 | 50 |
| 26 RPN-DFM | 3/4"-14 | 25 |
| 27 RPN-DFM | 1/2"-16 | 50 |
| 28 RPN-DFM | 3/4"-16 | 25 |
| 29 RPN-DFM | 1/2"-19 | 50 |
| 30 RPN-DFM | 3/4"-19 | 25 |
| 31 RPN-DFM | 1" -19 | 25 |

RPN-LFM



| COD | Ø | 🛒 |
|------------|---------|----|
| 1 RPN-LFM | 1/8"- 4 | 50 |
| 2 RPN-LFM | 1/4"- 4 | 50 |
| 3 RPN-LFM | 1/8"- 5 | 50 |
| 4 RPN-LFM | 1/4"- 5 | 50 |
| 5 RPN-LFM | 1/2"- 5 | 50 |
| 6 RPN-LFM | 1/8"- 6 | 50 |
| 7 RPN-LFM | 1/4"- 6 | 50 |
| 8 RPN-LFM | 3/8"- 6 | 50 |
| 9 RPN-LFM | 1/2"- 6 | 50 |
| 10 RPN-LFM | 1/8"- 8 | 50 |
| 11 RPN-LFM | 1/4"- 8 | 50 |
| 12 RPN-LFM | 3/8"- 8 | 50 |
| 13 RPN-LFM | 1/2"- 8 | 50 |
| 14 RPN-LFM | 1/4"-10 | 50 |
| 15 RPN-LFM | 3/8"-10 | 50 |
| 16 RPN-LFM | 1/2"-10 | 50 |
| 17 RPN-LFM | 3/4"-10 | 25 |
| 18 RPN-LFM | 1/4"-12 | 50 |
| 19 RPN-LFM | 3/8"-12 | 50 |
| 20 RPN-LFM | 1/2"-12 | 50 |
| 21 RPN-LFM | 3/4"-12 | 25 |
| 22 RPN-LFM | 3/8"-14 | 50 |
| 23 RPN-LFM | 1/2"-14 | 50 |
| 24 RPN-LFM | 3/4"-14 | 25 |
| 25 RPN-LFM | 1/2"-16 | 50 |
| 26 RPN-LFM | 3/4"-16 | 25 |
| 27 RPN-LFM | 1/2"-19 | 50 |
| 28 RPN-LFM | 3/4"-19 | 25 |

RPN-TFM



| COD | Ø | 🛒 |
|------------|---------|----|
| 1 RPN-TFM | 1/8"- 4 | 50 |
| 2 RPN-TFM | 1/4"- 4 | 50 |
| 3 RPN-TFM | 1/8"- 5 | 50 |
| 4 RPN-TFM | 1/4"- 5 | 50 |
| 5 RPN-TFM | 1/8"- 6 | 50 |
| 6 RPN-TFM | 1/4"- 6 | 50 |
| 7 RPN-TFM | 3/8"- 6 | 50 |
| 8 RPN-TFM | 1/2"- 6 | 50 |
| 9 RPN-TFM | 1/8"- 8 | 50 |
| 10 RPN-TFM | 1/4"- 8 | 50 |
| 11 RPN-TFM | 3/8"- 8 | 50 |
| 12 RPN-TFM | 1/2"- 8 | 50 |
| 13 RPN-TFM | 1/4"-10 | 50 |
| 14 RPN-TFM | 3/8"-10 | 50 |
| 15 RPN-TFM | 1/2"-10 | 50 |
| 16 RPN-TFM | 3/4"-10 | 50 |
| 17 RPN-TFM | 1/4"-12 | 25 |
| 18 RPN-TFM | 3/8"-12 | 50 |
| 19 RPN-TFM | 1/2"-12 | 50 |
| 20 RPN-TFM | 3/4"-12 | 50 |
| 21 RPN-TFM | 3/8"-14 | 25 |
| 22 RPN-TFM | 1/2"-14 | 50 |
| 23 RPN-TFM | 3/4"-14 | 50 |
| 24 RPN-TFM | 1/2"-16 | 25 |
| 25 RPN-TFM | 3/4"-16 | 50 |
| 26 RPN-TFM | 1/2"-19 | 25 |
| 27 RPN-TFM | 3/4"-19 | 50 |

RACCORDI PORTAGOMMA IN NYLON - NYLON HOSE FITTINGS



| RPN-L | | | |
|---------|----|--|----|
| COD | Ø | | 🛒 |
| 1 RPN-L | 4 | | 50 |
| 2 RPN-L | 5 | | 50 |
| 3 RPN-L | 6 | | 50 |
| 4 RPN-L | 8 | | 50 |
| 5 RPN-L | 10 | | 50 |
| 6 RPN-L | 12 | | 50 |
| 7 RPN-L | 14 | | 25 |
| 8 RPN-L | 16 | | 25 |
| 9 RPN-L | 19 | | 25 |



| RPN-LL | | | | |
|-----------|----|----|--|----|
| COD | Ø1 | Ø2 | | 🛒 |
| 1 RPN-LL | 5 | 4 | | 50 |
| 2 RPN-LL | 6 | 4 | | 25 |
| 3 RPN-LL | 6 | 5 | | 50 |
| 4 RPN-LL | 8 | 6 | | 50 |
| 5 RPN-LL | 10 | 6 | | 50 |
| 6 RPN-LL | 10 | 8 | | 50 |
| 7 RPN-LL | 12 | 10 | | 25 |
| 8 RPN-LL | 14 | 12 | | 25 |
| 9 RPN-LL | 16 | 14 | | 25 |
| 10 RPN-LL | 19 | 16 | | 25 |



| RPN-D | | | |
|---------|----|--|----|
| COD | Ø | | 🛒 |
| 1 RPN-D | 4 | | 50 |
| 2 RPN-D | 5 | | 50 |
| 3 RPN-D | 6 | | 50 |
| 4 RPN-D | 8 | | 50 |
| 5 RPN-D | 10 | | 50 |
| 6 RPN-D | 12 | | 50 |
| 7 RPN-D | 14 | | 25 |
| 8 RPN-D | 16 | | 25 |
| 9 RPN-D | 19 | | 25 |

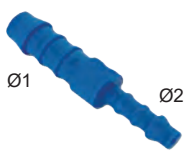

| RPN-DD | | | | |
|-----------|----|----|--|----|
| COD | Ø1 | Ø2 | | 🛒 |
| 1 RPN-DD | 5 | 4 | | 50 |
| 2 RPN-DD | 6 | 4 | | 50 |
| 3 RPN-DD | 6 | 5 | | 50 |
| 4 RPN-DD | 8 | 5 | | 50 |
| 5 RPN-DD | 8 | 6 | | 50 |
| 6 RPN-DD | 10 | 6 | | 50 |
| 7 RPN-DD | 10 | 8 | | 50 |
| 8 RPN-DD | 12 | 8 | | 50 |
| 9 RPN-DD | 12 | 10 | | 50 |
| 10 RPN-DD | 14 | 10 | | 25 |
| 11 RPN-DD | 14 | 12 | | 25 |
| 12 RPN-DD | 16 | 12 | | 25 |
| 13 RPN-DD | 16 | 14 | | 25 |
| 14 RPN-DD | 19 | 14 | | 25 |
| 15 RPN-DD | 19 | 16 | | 25 |



| RPN-T | | | |
|---------|----|--|----|
| COD | Ø | | 🛒 |
| 1 RPN-T | 4 | | 50 |
| 2 RPN-T | 5 | | 50 |
| 3 RPN-T | 6 | | 50 |
| 4 RPN-T | 8 | | 50 |
| 5 RPN-T | 10 | | 50 |
| 6 RPN-T | 12 | | 50 |
| 7 RPN-T | 14 | | 25 |
| 8 RPN-T | 16 | | 25 |
| 9 RPN-T | 19 | | 25 |



| RPN-DFF | | | |
|------------|------|----|----|
| COD | Ø | | 🛒 |
| 1 RPN-DFF | 1/8" | 4 | 50 |
| 2 RPN-DFF | 1/4" | 4 | 50 |
| 3 RPN-DFF | 1/8" | 5 | 50 |
| 4 RPN-DFF | 1/4" | 5 | 50 |
| 5 RPN-DFF | 3/8" | 5 | 50 |
| 6 RPN-DFF | 1/4" | 6 | 50 |
| 7 RPN-DFF | 3/8" | 6 | 50 |
| 8 RPN-DFF | 1/2" | 6 | 50 |
| 9 RPN-DFF | 1/4" | 8 | 50 |
| 10 RPN-DFF | 3/8" | 8 | 50 |
| 11 RPN-DFF | 1/2" | 8 | 50 |
| 12 RPN-DFF | 3/4" | 8 | 50 |
| 13 RPN-DFF | 3/8" | 10 | 25 |
| 14 RPN-DFF | 1/2" | 10 | 50 |
| 15 RPN-DFF | 3/4" | 10 | 50 |
| 16 RPN-DFF | 1/2" | 12 | 25 |
| 17 RPN-DFF | 3/4" | 12 | 50 |
| 18 RPN-DFF | 1/2" | 14 | 25 |
| 19 RPN-DFF | 3/4" | 14 | 50 |
| 20 RPN-DFF | 3/4" | 16 | 25 |
| 21 RPN-DFF | 3/4" | 19 | 25 |

GIREVOLE
SWIVEL



| RPN-TTT | | | | |
|-----------|----|----|--|----|
| COD | Ø1 | Ø2 | | 🛒 |
| 1 RPN-TTT | 5 | 4 | | 50 |
| 2 RPN-TTT | 6 | 5 | | 50 |
| 3 RPN-TTT | 8 | 6 | | 50 |
| 4 RPN-TTT | 10 | 8 | | 50 |
| 5 RPN-TTT | 12 | 10 | | 50 |
| 6 RPN-TTT | 14 | 12 | | 25 |
| 7 RPN-TTT | 16 | 14 | | 25 |
| 8 RPN-TTT | 19 | 16 | | 25 |



| RPN-Y | | | |
|---------|----|--|----|
| COD | Ø | | 🛒 |
| 1 RPN-Y | 4 | | 50 |
| 2 RPN-Y | 6 | | 50 |
| 3 RPN-Y | 8 | | 50 |
| 4 RPN-Y | 10 | | 50 |
| 5 RPN-Y | 12 | | 25 |

RACCORDI PORTAGOMMA IN NYLON

Colori Disponibili: blu - bianco - trasparente
Per materiali e/o dimensioni a richiesta contattare il nostro Ufficio Tecnico.

NYLON HOSE FITTINGS

Available colors: blue - white - transparent
For materials and / or dimensions on request, contact our Technical Department.

| RPP-DFM | | | |
|---|------------|----------|----|
| | COD | Ø | 🛒 |
|  | 1 RPP-DFM | 1/8"- 12 | 50 |
| | 2 RPP-DFM | 1/4"- 12 | 50 |
| | 3 RPP-DFM | 3/8"- 12 | 50 |
| | 4 RPP-DFM | 1/2"- 12 | 50 |
| | 5 RPP-DFM | 3/4"- 12 | 25 |
| | 6 RPP-DFM | 1/4"- 16 | 50 |
| | 7 RPP-DFM | 1/2"- 16 | 50 |
| | 8 RPP-DFM | 3/4"- 16 | 25 |
| | 9 RPP-DFM | 1/2"- 20 | 50 |
| | 10 RPP-DFM | 3/4"- 20 | 25 |
| | 11 RPP-DFM | 1" - 20 | 25 |
| | 12 RPP-DFM | 1/2"- 25 | 50 |
| | 13 RPP-DFM | 3/4"- 25 | 25 |
| | 14 RPP-DFM | 1" - 25 | 25 |

| RPP-LFM | | | |
|--|------------|----------|----|
| | COD | Ø | 🛒 |
|  | 1 RPP-LFM | 1/4"- 12 | 50 |
| | 2 RPP-LFM | 3/8"- 12 | 50 |
| | 3 RPP-LFM | 1/2"- 12 | 50 |
| | 4 RPP-LFM | 3/4"- 12 | 25 |
| | 5 RPP-LFM | 3/8"- 16 | 50 |
| | 6 RPP-LFM | 1/2"- 16 | 50 |
| | 7 RPP-LFM | 3/4"- 16 | 25 |
| | 8 RPP-LFM | 1/2"- 20 | 50 |
| | 9 RPP-LFM | 3/4"- 20 | 25 |
| | 10 RPP-LFM | 1/2"- 25 | 50 |
| | 11 RPP-LFM | 3/4"- 25 | 25 |

| RPP-TFM | | | |
|---|------------|----------|----|
| | COD | Ø | 🛒 |
|  | 1 RPP-TFM | 1/4"- 12 | 50 |
| | 2 RPP-TFM | 3/8"- 12 | 50 |
| | 3 RPP-TFM | 1/2"- 12 | 50 |
| | 4 RPP-TFM | 3/4"- 12 | 25 |
| | 5 RPP-TFM | 3/8"- 16 | 50 |
| | 6 RPP-TFM | 1/2"- 16 | 50 |
| | 7 RPP-TFM | 3/4"- 16 | 25 |
| | 8 RPP-TFM | 1/2"- 20 | 50 |
| | 9 RPP-TFM | 3/4"- 20 | 25 |
| | 10 RPP-TFM | 1/2"- 25 | 50 |
| | 11 RPP-TFM | 3/4"- 25 | 25 |

| RPP-FF | | | |
|--|-----------|----------|----|
| | COD | Ø | 🛒 |
|  | 1 RPP-FF | 3/4"- 6 | 25 |
| | 2 RPP-FF | 3/4"- 8 | 25 |
| | 3 RPP-FF | 1" - 8 | 25 |
| | 4 RPP-FF | 3/8"- 10 | 50 |
| | 5 RPP-FF | 3/4"- 10 | 25 |
| | 6 RPP-FF | 1/2"- 12 | 50 |
| | 7 RPP-FF | 3/4"- 12 | 25 |
| | 8 RPP-FF | 1" - 12 | 25 |
| | 9 RPP-FF | 3/4"- 14 | 25 |
| | 10 RPP-FF | 1" - 14 | 25 |
| | 11 RPP-FF | 3/4"- 16 | 25 |
| | 12 RPP-FF | 1" - 16 | 25 |
| | 13 RPP-FF | 3/4"- 19 | 25 |
| | 14 RPP-FF | 1" - 19 | 25 |

| RPP-T | | | |
|---|---------|----|----|
| | COD | Ø | 🛒 |
|  | 1 RPP-T | 12 | 50 |
| | 2 RPP-T | 16 | 25 |
| | 3 RPP-T | 20 | 25 |
| | 4 RPP-T | 25 | 25 |

| GG-FF | | | |
|---|---------|------|----|
| | COD | Ø | 🛒 |
|  | 1 GG-FF | 3/8" | 25 |
| | 2 GG-FF | 1/2" | 25 |
| | 3 GG-FF | 3/4" | 25 |
| | 4 GG-FF | 1" | 25 |

| RPP-L | | | |
|---|---------|----|----|
| | COD | Ø | 🛒 |
|  | 1 RPP-L | 12 | 50 |
| | 2 RPP-L | 16 | 25 |
| | 3 RPP-L | 20 | 25 |
| | 4 RPP-L | 25 | 25 |

| RPP-LL | | | | |
|--|----------|----|----|----|
| | COD | Ø1 | Ø2 | 🛒 |
|  | 1 RPP-LL | 16 | 12 | 25 |
| | 2 RPP-LL | 20 | 12 | 25 |
| | 3 RPP-LL | 20 | 16 | 25 |
| | 4 RPP-LL | 25 | 20 | 25 |

| RPP-D | | | |
|---|---------|----|----|
| | COD | Ø | 🛒 |
|  | 1 RPP-D | 12 | 25 |
| | 2 RPP-D | 16 | 25 |
| | 3 RPP-D | 20 | 25 |
| | 4 RPP-D | 25 | 25 |

| RPP-DD | | | | |
|--|----------|----|----|----|
| | COD | Ø1 | Ø2 | 🛒 |
|  | 1 RPP-DD | 16 | 12 | 25 |
| | 2 RPP-DD | 20 | 12 | 25 |
| | 3 RPP-DD | 20 | 16 | 25 |
| | 4 RPP-DD | 25 | 20 | 25 |

RACCORDI PORTAGOMMA IN POLIPROPILENE

Colori disponibili: nero - bianco - trasparente - Per materiali e/o dimensioni a richiesta contattare il nostro Ufficio Tecnico.

POLYPROPYLENE HOSE FITTINGS

























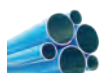

Available colors: blue - white - transparent - For materials and/or dimensions on request, contact our Technical Department.





COMPRESSION FITTINGS

RACCORDI A COMPRESSIONE IN TECNOPOLIMERO - PLASTIC COMPRESSION FITTINGS

| | | | | | |
|---|-----------|-----|--|------------|-----|
|  | RCP-M | 108 |  | RCP-T90 | 111 |
|  | RCP- MR | 108 |  | RCP-G45M | 111 |
|  | RCP-RM | 108 |  | RCP-G45F | 111 |
|  | RCP-RF | 108 |  | G | 111 |
|  | RCP-G90 | 109 |  | AS | 111 |
|  | RCP-GM90 | 109 |  | AG | 111 |
|  | RCP-GF90 | 109 |  | AT | 111 |
|  | RCP-G45 | 109 |  | AR | 111 |
|  | RCP-TT | 109 |  | STU | 111 |
|  | RCP-T90R | 110 |  | 1 TU-AL-16 | 112 |
|  | RCP-TM | 110 |  | SF 16 | 112 |
|  | RCP-TF | 110 |  | CK | 113 |
|  | RCP-RFL | 110 |  | GCK | 113 |
|  | RCP-RFL90 | 110 |  | FCK | 113 |
|  | RCP-TFL | 111 | | | |

I raccordi a compressione in tecnopolimero sono conosciuti in tutto il mondo per il loro ottimo rapporto qualità-prezzo e la loro lunga vita di servizio. Vengono impiegati per collegare tubi in polietilene e per la distribuzione di fluidi in pressione. In particolare sono usati per il trasporto di acqua potabile negli acquedotti e negli impianti civili, nell'irrigazione, negli impianti antincendio, negli impianti geotermici, per il convogliamento di acque reflue e industriali, per la distribuzione di aria compressa.

Plastic compression fittings are known worldwide for their excellent and long service life. They are used for connecting polyethylene pipes and for the distribution of pressurised fluids. They are used in particular for the transport of drinking water in aqueducts and civil installations, irrigation, fire-fighting systems, geothermal systems, the conveyance of waste and industrial water and the distribution of compressed air.

| | |
|--|---|
| <p>CORPO - BODY</p>  <p>Polipropilene nero ad alto impatto stabilizzato UV e con elevata stabilità all'invecchiamento. <i>UV stabilized high impact black polypropylene and with high aging stability.</i></p> | <p>GHIERA - NUT</p>  <p>Polipropilene blu ad alto impatto, stabilizzato UV. <i>High impact blue polypropylene, UV stabilized.</i></p> |
| <p>ANELLO DI GRAFFAGGIO - CLINCHING RING</p>  <p>Resina acetica (POM) <i>Acetal resin (POM)</i></p> | <p>ANELLO DI SPINTA - THRUST RING</p>  <p>Tecnopolimero nero ad alto impatto stabilizzato UV. <i>UV stabilized high impact black plastic.</i></p> |
| <p>ANELLO DI RINFORZO - REINFORCEMENT RING</p>  <p>Acciaio inox AISI 430 <i>AISI 430 Stainless Steel</i></p> | <p>GUARNIZIONE - GASKET</p>  <p>Gomma nitrica nera (NBR) <i>Black Nitric Rubber (NBR)</i></p> |

TEMPERATURA E PRESSIONE DI ESERCIZIO
 Ø 16÷110 = 20°C-16 Bar, 45°C-10 Bar, 70°C-3 Bar
 Ø 3"- 4" Filettato femmina = 20°C-10 Bar, 45°C-6.7 Bar, 70°C-2 Bar

PRESSIONE DI ESERCIZIO
 Ø 16÷110 = 16 Bar
 Ø 3"- 4" Filettato femmina = 10 Bar

PRESSIONE MASSIMA
 Ø 16÷110 = 20 Bar
 Ø 3"- 4" Filettato femmina = 12,5 Bar

PRESSIONE DI PROVA
 Ø 16÷110 = 24 Bar
 Ø 3"- 4" Filettato femmina = 15 Bar

IDONEITÀ AL CONTATTO CON ACQUA POTABILE
 DM 174-06/04/2004 (Italy), DM 23/04/2009 e Reg. UE N° 10/2011,
 W270 AND KTW (Germany), ATA (Netherlands),
 Global Mark (Australia), ACS (France), WRAS (UK).

NORME DI RIFERIMENTO

Tubi: UNI EN 12201, ISO 11922-1, DIN 8074, AS/NZS 4130, BS 6572, BS 6730, ISO 4427, UNI 7990, ISO 12162.
 Filetti BSP: UNI EN 10226 (ISO 7-1), BS 21, AS 1722.1
 Filetti NPT: ANSI-ASME B1.20.1
 Flange: UNI EN1092-1, ISO 7005-1, DIN 2501.1, BS 4504
 Tubi scanalati (tipo Victaulic): ANSI/AWWA C 606-87
 Prove: SO 17885 (EX ISO 14236), DIN 8076-3, AS/NZS 4129, BRL K534/03 –UNI, ISO 3501, ISO 3503, ISO 3458, ISO 459, VP609

REFERENCE STANDARDS

*Tubes: UNI EN 12201, ISO 11922-1, DIN 8074, AS/NZS 4130, BS 6572, BS 6730, ISO 4427, UNI 7990, ISO 12162.
 BSP Threads: UNI EN 10226 (ISO 7-1), BS 21, AS 1722.1
 NPT Threads: ANSI-ASME B1.20.1
 Flanges: UNI EN1092-1, ISO 7005-1, DIN 2501.1, BS 4504
 Grooved pipes (Victaulic type): ANSI/AWWA C 606-87
 Test: ISO 17885 (EX ISO 14236), DIN 8076-3, AS/NZS 4129, BRL K534/03 –UNI, ISO 3501, ISO 3503, ISO 3458, ISO 459, VP609*

WORKING TEMPERATURE AND PRESSURE
 Ø 16÷110 = 20°C-16 Bar, 45°C-10 Bar, 70°C-3 Bar
 Ø 3"- 4" Female thread = 20°C-10 Bar, 45°C-6.7 Bar, 70°C-2 Bar

OPERATING PRESSURE
 Ø 16÷110 = 16 Bar
 Ø 3"- 4" Female thread = 10 Bar

MAX PRESSURE
 Ø 16÷110 = 20 Bar
 Ø 3"- 4" Female thread = 12,5 Bar

TEST PRESSURE
 Ø 16÷110 = 24 Bar
 Ø 3"- 4" Female thread = 15 Bar

SUITABILITY FOR CONTACT WITH DRINKING WATER
 DM 174-06/04/2004 (Italy), DM 23/04/2009 e Reg. UE N° 10/2011
 W270 AND KTW (Germany), ATA (Netherlands),
 Global Mark (Australia), ACS (France), WRAS (UK).

RCP-M MANICOTTO
RCP-M COUPLING



RCP-M

| COD | DIMENSIONI SIZES | 🛒 |
|----------|---------------------|----|
| 1 RCP M | 16 | 20 |
| 2 RCP M | 20 | 20 |
| 3 RCP M | 25 | 20 |
| 4 RCP M | 32 | 10 |
| 5 RCP M | 40 | 10 |
| 6 RCP M | 50 | 5 |
| 7 RCP M | 63 | 1 |
| 8 RCP M | 75 | 1 |
| 9 RCP M | 90 | 1 |
| 10 RCP M | 110 | 1 |

RCP-MR MANICOTTO RIDOTTO
RCP-MR REDUCING COUPLING



RCP-MR

| COD | DIMENSIONI SIZES | 🛒 |
|-----------|---------------------|----|
| 1 RCP MR | 20-16 | 20 |
| 2 RCP MR | 25-16 | 20 |
| 3 RCP MR | 25-20 | 20 |
| 4 RCP MR | 32-20 | 10 |
| 5 RCP MR | 32-25 | 10 |
| 6 RCP MR | 40-32 | 5 |
| 7 RCP MR | 50-32 | 1 |
| 8 RCP MR | 50-40 | 1 |
| 9 RCP MR | 63-32 | 1 |
| 10 RCP MR | 63-40 | 1 |
| 11 RCP MR | 63-50 | 1 |
| 12 RCP MR | 75-40 | 1 |
| 13 RCP MR | 75-50 | 1 |
| 14 RCP MR | 75-63 | 1 |
| 15 RCP MR | 90-63 | 1 |
| 16 RCP MR | 90-75 | 1 |
| 17 RCP MR | 110-75 | 1 |
| 18 RCP MR | 110-90 | 1 |

RCP-RM RACCORDO MASCHIO
RCP-RM MALE ADAPTOR



RCP-RM

| COD | DIMENSIONI SIZES | 🛒 |
|-----------|---------------------|----|
| 1 RCP RM | 16 x 1/2" | 20 |
| 2 RCP RM | 16 x 3/4" | 20 |
| 3 RCP RM | 20 x 1/2" | 20 |
| 4 RCP RM | 20 x 3/4" | 20 |
| 5 RCP RM | 25 x 1/2" | 20 |
| 6 RCP RM | 25 x 3/4" | 20 |
| 7 RCP RM | 25 x 1" | 20 |
| 8 RCP RM | 32 x 3/4" | 20 |
| 9 RCP RM | 32 x 1" | 20 |
| 10 RCP RM | 32 x 1 1/4" | 20 |
| 11 RCP RM | 40 x 1" | 10 |
| 12 RCP RM | 40 x 1 1/4" | 10 |
| 13 RCP RM | 40 x 1 1/2" | 10 |
| 14 RCP RM | 50 x 1 1/4" | 5 |
| 15 RCP RM | 50 x 1 1/2" | 5 |
| 16 RCP RM | 50 x 2" | 5 |
| 17 RCP RM | 63 x 1 1/2" | 1 |
| 18 RCP RM | 63 x 2" | 1 |
| 19 RCP RM | 63 x 2 1/2" | 1 |
| 20 RCP RM | 75 x 2" | 1 |
| 21 RCP RM | 75 x 2 1/2" | 1 |
| 22 RCP RM | 75 x 3" | 1 |
| 23 RCP RM | 90 x 2" | 1 |
| 24 RCP RM | 90 x 2 1/2" | 1 |
| 25 RCP RM | 90 x 3" | 1 |
| 26 RCP RM | 90 x 4" | 1 |
| 27 RCP RM | 110 x 3" | 1 |
| 28 RCP RM | 110 x 4" | 1 |

RCP-RF RACCORDO FEMMINA
RCP-RF FEMALE FITTING



RCP-RF

| COD | DIMENSIONI SIZES | 🛒 |
|-----------|---------------------|----|
| 1 RCP RF | 16 x 1/2" | 20 |
| 2 RCP RF | 16 x 3/4" | 20 |
| 3 RCP RF | 20 x 1/2" | 20 |
| 4 RCP RF | 20 x 3/4" | 20 |
| 5 RCP RF | 25 x 1/2" | 20 |
| 6 RCP RF | 25 x 3/4" | 20 |
| 7 RCP RF | 25 x 1" | 20 |
| 8 RCP RF | 32 x 3/4" | 20 |
| 9 RCP RF | 32 x 1" | 20 |
| 10 RCP RF | 40 x 1" | 10 |
| 11 RCP RF | 40 x 1 1/4" | 10 |
| 12 RCP RF | 40 x 1 1/2" | 5 |
| 13 RCP RF | 50 x 1 1/4" | 5 |
| 14 RCP RF | 50 x 1 1/2" | 5 |
| 15 RCP RF | 50 x 2" | 5 |
| 16 RCP RF | 63 x 2" | 1 |
| 17 RCP RF | 75 x 2" | 1 |
| 18 RCP RF | 75 x 2 1/2" | 1 |
| 19 RCP RF | 90 x 3" | 1 |
| 20 RCP RF | 110 x 3" | 1 |
| 21 RCP RF | 110 x 4" | 1 |



Dal Ø 2" al Ø 4" con anello di rinforzo di serie.
Anello opzionale per tutte le misure inferiori.
From ø 2 "to ø 4 " with reinforcement ring as standard. Optional ring for all sizes lower.

RCP-G90 GOMITO A 90°
RCP-G90 90° ELBOW



RCP-G90

| COD | DIMENSIONI SIZES | 🛒 |
|------------|---------------------|----|
| 1 RCP-G90 | 16 | 20 |
| 2 RCP-G90 | 20 | 20 |
| 3 RCP-G90 | 25 | 20 |
| 4 RCP-G90 | 32 | 10 |
| 5 RCP-G90 | 40 | 10 |
| 6 RCP-G90 | 50 | 5 |
| 7 RCP-G90 | 63 | 1 |
| 8 RCP-G90 | 75 | 1 |
| 9 RCP-G90 | 90 | 1 |
| 10 RCP-G90 | 110 | 1 |

RCP-GM90 GOMITO A 90° FILETTATO MASCHIO
RCP-GM90 90° MALE THREADED ELBOW



RCP-GM90

| COD | DIMENSIONI SIZES | 🛒 |
|-------------|---------------------|----|
| 1 RCP-GM90 | 16 x 1/2" | 20 |
| 2 RCP-GM90 | 16 x 3/4" | 20 |
| 3 RCP-GM90 | 20 x 1/2" | 20 |
| 4 RCP-GM90 | 20 x 3/4" | 20 |
| 5 RCP-GM90 | 25 x 1/2" | 20 |
| 6 RCP-GM90 | 25 x 3/4" | 20 |
| 7 RCP-GM90 | 25 x 1" | 20 |
| 8 RCP-GM90 | 32 x 3/4" | 10 |
| 9 RCP-GM90 | 32 x 1" | 10 |
| 10 RCP-GM90 | 32 x 1 1/4" | 10 |
| 11 RCP-GM90 | 40 x 1" | 5 |
| 12 RCP-GM90 | 40 x 1 1/4" | 5 |
| 13 RCP-GM90 | 40 x 1 1/2" | 5 |
| 14 RCP-GM90 | 40 x 2" | 5 |
| 15 RCP-GM90 | 50 x 1 1/4" | 5 |
| 16 RCP-GM90 | 50 x 1 1/2" | 5 |
| 17 RCP-GM90 | 50 x 2" | 1 |
| 18 RCP-GM90 | 63 x 1 1/2" | 1 |
| 19 RCP-GM90 | 63 x 2" | 1 |
| 20 RCP-GM90 | 63 x 2 1/2" | 1 |
| 21 RCP-GM90 | 75 x 2" | 1 |
| 22 RCP-GM90 | 75 x 2 1/2" | 1 |
| 23 RCP-GM90 | 75 x 3" | 1 |
| 24 RCP-GM90 | 90 x 3" | 1 |
| 24 RCP-GM90 | 90 x 4" | 1 |
| 26 RCP-GM90 | 110 x 4" | 1 |

RCP-GF90 GOMITO A 90° FILETTATO FEMMINA
RCP-GF90 90° FEMALE THREADED ELBOW



RCP-GF90

| COD | DIMENSIONI SIZES | 🛒 |
|-------------|---------------------|----|
| 1 RCP-GF90 | 16 x 1/2" | 20 |
| 2 RCP-GF90 | 16 x 3/4" | 20 |
| 3 RCP-GF90 | 20 x 1/2" | 20 |
| 4 RCP-GF90 | 20 x 3/4" | 20 |
| 5 RCP-GF90 | 25 x 1/2" | 20 |
| 6 RCP-GF90 | 25 x 3/4" | 20 |
| 7 RCP-GF90 | 25 x 1" | 20 |
| 8 RCP-GF90 | 32 x 3/4" | 10 |
| 9 RCP-GF90 | 32 x 1" | 10 |
| 10 RCP-GF90 | 40 x 1" | 5 |
| 11 RCP-GF90 | 40 x 1 1/4" | 5 |
| 12 RCP-GF90 | 50 x 1 1/2" | 5 |
| 13 RCP-GF90 | 50 x 2" | 1 |
| 14 RCP-GF90 | 63 x 1 1/2" | 1 |
| 15 RCP-GF90 | 63 x 2" | 1 |
| 16 RCP-GF90 | 75 x 2" | 1 |
| 17 RCP-GF90 | 75 x 2 1/2" | 1 |
| 18 RCP-GF90 | 90 x 2 1/2" | 1 |
| 19 RCP-GF90 | 90 x 3" | 1 |
| 20 RCP-GF90 | 110 x 3" | 1 |
| 21 RCP-GF90 | 110 x 4" | 1 |

Dal Ø 2" al Ø 4" con anello di rinforzo di serie.
Anello opzionale per tutte le misure inferiori.

From ø 2 "to ø 4" with reinforcement ring as standard. Optional ring for all sizes lower.



RCP-G45 GOMITO A 45°
RCP-G45 45° ELBOW



RCP-G45

| COD | DIMENSIONI SIZES | 🛒 |
|-----------|---------------------|----|
| 1 RCP-G45 | 20 | 20 |
| 2 RCP-G45 | 25 | 20 |

RCP-TT TAPPO TERMINALE
RCP-TT END CAP



RCP-TT

| COD | DIMENSIONI SIZES | 🛒 |
|-----------|---------------------|----|
| 1 RCP-TT | 16 | 20 |
| 2 RCP-TT | 20 | 20 |
| 3 RCP-TT | 25 | 20 |
| 4 RCP-TT | 32 | 20 |
| 5 RCP-TT | 40 | 10 |
| 6 RCP-TT | 50 | 10 |
| 7 RCP-TT | 63 | 1 |
| 8 RCP-TT | 75 | 1 |
| 9 RCP-TT | 90 | 1 |
| 10 RCP-TT | 110 | 1 |

RCP-T90R TEE A 90° RIDOTTO
RCP-T90R REDUCED 90° TEE



RCP-90R

| COD | DIMENSIONI SIZES | 🛒 |
|-------------|---------------------|----|
| 1 RCP-T90R | 20-16-20 | 10 |
| 2 RCP-T90R | 20-25-20 | 10 |
| 3 RCP-T90R | 25-16-25 | 10 |
| 4 RCP-T90R | 25-20-25 | 10 |
| 5 RCP-T90R | 25-32-25 | 10 |
| 6 RCP-T90R | 32-20-32 | 5 |
| 7 RCP-T90R | 32-25-32 | 5 |
| 8 RCP-T90R | 40-25-32 | 1 |
| 9 RCP-T90R | 40-32-40 | 1 |
| 10 RCP-T90R | 50-20-50 | 1 |
| 11 RCP-T90R | 50-25-50 | 1 |
| 12 RCP-T90R | 50-32-50 | 1 |
| 13 RCP-T90R | 50-40-50 | 1 |
| 14 RCP-T90R | 63-20-63 | 1 |
| 15 RCP-T90R | 63-25-63 | 1 |
| 16 RCP-T90R | 63-32-63 | 1 |
| 17 RCP-T90R | 63-40-63 | 1 |
| 18 RCP-T90R | 63-50-63 | 1 |
| 19 RCP-T90R | 75-63-75 | 1 |
| 20 RCP-T90R | 90-75-90 | 1 |
| 21 RCP-T90R | 110-90-110 | 1 |

RCP-TM TEE A 90° FILETTATO MASCHIO
RCP-TM MALE THREADED 90° TEE



RCP-TM

| COD | DIMENSIONI SIZES | 🛒 |
|-----------|---------------------|----|
| 1 RCP-TM | 16 x 1/2" | 10 |
| 2 RCP-TM | 16 x 3/4" | 10 |
| 3 RCP-TM | 20 x 1/2" | 10 |
| 4 RCP-TM | 20 x 3/4" | 20 |
| 5 RCP-TM | 25 x 1/2" | 10 |
| 6 RCP-TM | 25 x 3/4" | 10 |
| 7 RCP-TM | 25 x 1" | 10 |
| 8 RCP-TM | 32 x 3/4" | 10 |
| 9 RCP-TM | 32 x 1" | 10 |
| 10 RCP-TM | 40 x 1" | 5 |
| 11 RCP-TM | 40 x 1 1/4" | 5 |
| 12 RCP-TM | 40 x 1 1/2" | 5 |
| 13 RCP-TM | 50 x 1 1/2" | 1 |
| 14 RCP-TM | 50 x 2" | 1 |
| 15 RCP-TM | 63 x 2" | 1 |
| 16 RCP-TM | 63 x 2 1/2" | 1 |
| 17 RCP-TM | 75 x 2" | 1 |
| 18 RCP-TM | 75 x 2 1/2" | 1 |
| 19 RCP-TM | 75 x 3" | 1 |
| 20 RCP-TM | 90 x 3" | 1 |
| 21 RCP-TM | 90 x 4" | 1 |
| 22 RCP-TM | 110 x 3" | 1 |
| 23 RCP-TM | 110 x 4" | 1 |

RCP-TF TEE A 90° FILETTATO FEMMINA
RCP-TF 90° FEMALE THREADED TEE



RCP-TF

| COD | DIMENSIONI SIZES | 🛒 |
|-----------|---------------------|----|
| 1 RCP-TF | 16 x 1/2" | 20 |
| 2 RCP-TF | 16 x 3/4" | 20 |
| 3 RCP-TF | 20 x 1/2" | 20 |
| 4 RCP-TF | 20 x 3/4" | 20 |
| 5 RCP-TF | 25 x 1/2" | 10 |
| 6 RCP-TF | 25 x 3/4" | 10 |
| 7 RCP-TF | 25 x 1" | 10 |
| 8 RCP-TF | 32 x 3/4" | 10 |
| 9 RCP-TF | 32 x 1" | 10 |
| 10 RCP-TF | 40 x 1" | 5 |
| 11 RCP-TF | 40 x 1 1/4" | 5 |
| 12 RCP-TF | 40 x 1 1/2" | 5 |
| 13 RCP-TF | 50 x 1 1/4" | 1 |
| 14 RCP-TF | 50 x 1 1/2" | 1 |
| 15 RCP-TF | 50 x 2" | 1 |
| 16 RCP-TF | 63 x 2" | 1 |
| 17 RCP-TF | 75 x 2" | 1 |
| 18 RCP-TF | 75 x 2 1/2" | 1 |
| 19 RCP-TF | 75 x 3" | 1 |
| 20 RCP-TF | 90 x 3" | 1 |
| 21 RCP-TF | 90 x 4" | 1 |
| 22 RCP-TF | 110 x 3" | 1 |
| 23 RCP-TF | 110 x 4" | 1 |



Dal Ø 2" al Ø 4" con anello di rinforzo di serie.
Anello opzionale per tutte le misure inferiori.
From ø 2 "to ø 4" with reinforcement ring as standard. Optional ring for all sizes lower.

RCP-RFL RACCORDO FLANGIATO
RCP-RFL FLANGED FITTING



RCP-RFL

| COD | DIMENSIONI SIZES | 🛒 |
|-----------|---------------------|----|
| 1 RCP-RFL | 50 x 1 1/2" | 25 |
| 2 RCP-RFL | 50 x 2" | 25 |
| 3 RCP-RFL | 63 x 2" | 20 |
| 4 RCP-RFL | 75 x 2 1/2" | 16 |
| 5 RCP-RFL | 75 x 3" | 10 |
| 6 RCP-RFL | 90 x 3" | 8 |
| 7 RCP-RFL | 90 x 4" | 8 |
| 8 RCP-RFL | 110 x 4" | 6 |

RCP-RFL90 GOMITO 90° FLANGIATO
RCP-RFL90 90° FLANGED ELBOW



RCP-RFL90

| COD | DIMENSIONI SIZES | 🛒 |
|-------------|---------------------|----|
| 1 RCP-RFL90 | 50 x 1 1/2" | 20 |
| 2 RCP-RFL90 | 50 x 2" | 20 |
| 3 RCP-RFL90 | 63 x 2" | 10 |
| 4 RCP-RFL90 | 75 x 2 1/2" | 12 |
| 5 RCP-RFL90 | 75 x 3" | 12 |
| 6 RCP-RFL90 | 90 x 3" | 6 |
| 7 RCP-RFL90 | 90 x 4" | 5 |
| 8 RCP-RFL90 | 110 x 4" | 4 |

RCP-TFL TEE FLANGIATA
RCP-TFL FLANGED TEE



RCP-TFL

| COD | DIMENSIONI SIZES | 🛒 |
|-----------|---------------------|----|
| 1 RCP-TFL | 50 x 1"1/2 | 15 |
| 2 RCP-TFL | 50 x 2" | 15 |
| 3 RCP-TFL | 63 x 2" | 10 |
| 4 RCP-TFL | 75 x 2"1/2 | 8 |
| 5 RCP-TFL | 75 x 3" | 8 |
| 6 RCP-TFL | 90 x 3" | 5 |
| 7 RCP-TFL | 90 x 4" | 4 |
| 8 RCP-TFL | 110 x 4" | 3 |

RCP-T90 TEE A 90°
RCP-T90 90° TEE



RCP-T90

| COD | DIMENSIONI SIZES | 🛒 |
|------------|---------------------|----|
| 1 RCP-T90 | 16 | 20 |
| 2 RCP-T90 | 20 | 20 |
| 3 RCP-T90 | 25 | 10 |
| 4 RCP-T90 | 32 | 10 |
| 5 RCP-T90 | 40 | 5 |
| 6 RCP-T90 | 50 | 1 |
| 7 RCP-T90 | 63 | 1 |
| 8 RCP-T90 | 75 | 1 |
| 9 RCP-T90 | 90 | 1 |
| 10 RCP-T90 | 110 | 1 |

RCP-G45M GOMITO A 45° FILETTATO MASCHIO
RCP-G45M 45° MALE THREADED ELBOW



RCP-G45M

| COD | DIMENSIONI SIZES | 🛒 |
|------------|---------------------|----|
| 1 RCP-G45M | 20 x 1/2" | 20 |
| 2 RCP-G45M | 20 x 3/4" | 20 |
| 3 RCP-G45M | 25 x 1/2" | 20 |
| 4 RCP-G45M | 25 x 3/4" | 20 |

RCP-G45F GOMITO A 45° FILETTATO FEMMINA
RCP-G45F 45° FEMALE THREADED ELBOW



RCP-G45F

| COD | DIMENSIONI SIZES | 🛒 |
|------------|---------------------|----|
| 1 RCP-G45F | 20 x 1/2" | 20 |
| 2 RCP-G45F | 20 x 3/4" | 20 |
| 3 RCP-G45F | 25 x 1/2" | 20 |
| 4 RCP-G45F | 25 x 3/4" | 20 |

RICAMBI ED ACCESSORI - SPARE PARTS AND ACCESSORIES

G GHIERA
G NUT



G

| COD | DIMENSIONI SIZES | 🛒 |
|------|---------------------|---|
| 1 G | 16 | 1 |
| 2 G | 20 | 1 |
| 3 G | 25 | 1 |
| 4 G | 32 | 1 |
| 5 G | 40 | 1 |
| 6 G | 50 | 1 |
| 7 G | 63 | 1 |
| 8 G | 75 | 1 |
| 9 G | 90 | 1 |
| 10 G | 110 | 1 |

AG ANELLO DI GRAFFAGGIO
AG SCRATCH RING



AG

| COD | DIMENSIONI SIZES | 🛒 |
|-------|---------------------|---|
| 1 AG | 16 | 1 |
| 2 AG | 20 | 1 |
| 3 AG | 25 | 1 |
| 4 AG | 32 | 1 |
| 5 AG | 40 | 1 |
| 6 AG | 50 | 1 |
| 7 AG | 63 | 1 |
| 8 AG | 75 | 1 |
| 9 AG | 90 | 1 |
| 10 AG | 110 | 1 |

AS ANELLO DI SPINTA
AS THRUST RING



AS

| COD | DIMENSIONI SIZES | 🛒 |
|-------|---------------------|---|
| 1 AS | 16 | 1 |
| 2 AS | 20 | 1 |
| 3 AS | 25 | 1 |
| 4 AS | 32 | 1 |
| 5 AS | 40 | 1 |
| 6 AS | 50 | 1 |
| 7 AS | 63 | 1 |
| 8 AS | 75 | 1 |
| 9 AS | 90 | 1 |
| 10 AS | 110 | 1 |

AT ANELLO DI TENUTA
AT SEALING RING



AT

| COD | DIMENSIONI SIZES | 🛒 |
|-------|---------------------|---|
| 1 AT | 16 | 1 |
| 2 AT | 20 | 1 |
| 3 AT | 25 | 1 |
| 4 AT | 32 | 1 |
| 5 AT | 40 | 1 |
| 6 AT | 50 | 1 |
| 7 AT | 63 | 1 |
| 8 AT | 75 | 1 |
| 9 AT | 90 | 1 |
| 10 AT | 110 | 1 |

AR ANELLO DI RINFORZO
AR REINFORCEMENT RING



AR

| COD | DIMENSIONI SIZES | 🛒 |
|------|---------------------|---|
| 1 AR | Ø 1/2" | 1 |
| 2 AR | Ø 3/4" | 1 |
| 3 AR | Ø 1" | 1 |
| 4 AR | Ø 1"1/4 | 1 |
| 5 AR | Ø 1"1/2 | 1 |
| 6 AR | Ø 2" | 1 |
| 7 AR | Ø 2"1/2 | 1 |
| 8 AR | Ø 3" | 1 |
| 9 AR | Ø 4" | 1 |

STU SBAVATORE PER TUBI PE / PPR
STU DEBURRER FOR PE / PPR PIPES



STU

| COD | DIMENSIONI SIZES | 🛒 |
|-------|---------------------|---|
| 1 STU | 0 - 40 | 1 |

RACCORDI A COMPRESSIONE IN TECNOPOLIMERO - *PLASTIC COMPRESSION FITTINGS*

TUBI IN ALLUMINIO CALIBRATI - *CALIBRATED ALUMINIUM TUBES*

| COD | DIMENSIONE SIZE Ø (mm) | SPESSORE THICKNESS (mm) | PRESSIONE PRESSURE (Bar) | PESO WEIGHT g/m | LUNGHEZZA BARRA LENGTH BAR (m) | 🛒 |
|--------------|------------------------------|-------------------------------|--------------------------------|-----------------------|--------------------------------------|----|
| 1 TU-AL-16 | 16 | 1,5 | 16 | 192 | 4,0 m | 20 |
| 2 TU-AL-20 | 20 | 1,5 | 16 | 235 | 5,8 m | 10 |
| 3 TU-AL-25 | 25 | 1,5 | 16 | 298 | 5,8 m | 8 |
| 4 TU-AL-32 | 32 | 1,5 | 16 | 387 | 5,8 m | 8 |
| 5 TU-AL-40 | 40 | 1,5 | 16 | 492 | 5,8 m | 4 |
| 6 TU-AL-50 | 50 | 2 | 16 | 814 | 5,8 m | 4 |
| 7 TU-AL-63 | 63 | 2 | 16 | 1034 | 5,8 m | 4 |
| 8 TU-AL-75 | 75 | 2 | 16 | 1245 | 5,8 m | 2 |
| 9 TU-AL-90 | 90 | 2 | 16 | 1517 | 5,8 m | 2 |
| 10 TU-AL-110 | 110 | 2,5 | 16 | 2280 | 5,8 m | 2 |

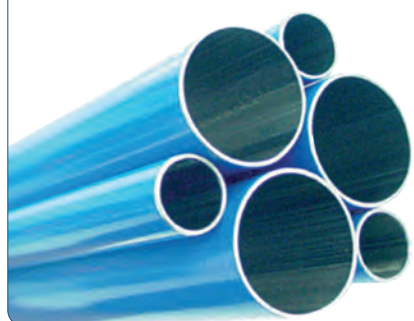

Colore: BLU - *Blue color*

LUNGHEZZA BARRA *BAR LENGTH*
 4,0 mt - Ø 16 mm *4,0 mt - Ø 16 mm*
 5,8 mt - Ø 20 ÷ 110 mm *5,8 mt - Ø 20 ÷ 110 mm*

FISSAGGI PER MONTAGGIO TUBO IN ALLUMINIO - *FIXINGS FOR ALUMINIUM PIPE ASSEMBLY*

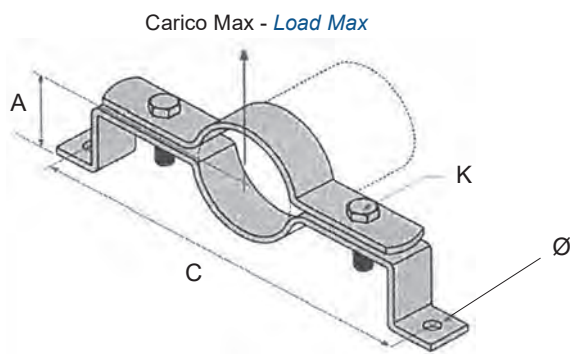

COLLARE DI SUPPORTO PER TUBO
SUPPORT COLLAR FOR PIPE

Materiale: Acciaio
Material: Steel

Finitura standard: Elettrozincatura
Standard finish: Electro-galvanizing

Caratteristiche:
Progettato per supportare tratti di tubi orizzontali o verticali.
*Features:
Designed to support horizontal or vertical pipe runs.*

| COD | DIAMETRO TUBO PIPE DIAMETER (mm) | BULLONE K BOLT K (mm) | A (mm) | Ø (mm) | C (mm) | CARICO MASSIMO LOAD MAX (kN) | 🛒 |
|--------|--|-----------------------------|--------|--------|--------|------------------------------------|----|
| SF 16 | 16 | M.10 | 63 | 11 | 152 | 0,84 | 25 |
| SF 20 | 20 | M.10 | 63 | 11 | 186 | 0,84 | 25 |
| SF 25 | 25 | M.10 | 67 | 11 | 192 | 0,84 | 25 |
| SF 32 | 32 | M.10 | 71 | 11 | 200 | 0,84 | 20 |
| SF 40 | 40 | M.10 | 75 | 11 | 209 | 0,84 | 20 |
| SF 50 | 50 | M.10 | 81 | 11 | 232 | 1,87 | 20 |
| SF 63 | 63 | M.10 | 87 | 11 | 267 | 1,87 | 15 |
| SF 75 | 75 | M.10 | 95 | 11 | 283 | 1,87 | 15 |
| SF 90 | 90 | M.10 | 95 | 11 | 283 | 1,87 | 15 |
| SF 110 | 110 | M.12 | 108 | 14 | 317 | 2,71 | 10 |

SCHEMA DISTRIBUZIONE IMPIANTO ARIA COMPRESSA
COMPRESSED AIR SYSTEM DISTRIBUTION DIAGRAM



RACCORDI A CALZAMENTO IN TECNOPOLIMERO - *QUICK RELEASE PLASTIC FITTINGS*



CK - DIRITTO - *STRAIGHT*



Conico
Taper

| COD | 🛒 |
|----------|----|
| CK 04-01 | 25 |
| CK 06-01 | 25 |
| CK 06-02 | 25 |
| CK 08-01 | 25 |
| CK 08-02 | 25 |
| CK 08-03 | 25 |
| CK 10-02 | 25 |
| CK 10-03 | 25 |
| CK 12-02 | 25 |
| CK 12-03 | 25 |
| CK 12-04 | 25 |

GCK - GOMITO - *ELBOW*



Conico
Taper

| COD | 🛒 |
|-----------|----|
| GCK 04-01 | 25 |
| GCK 06-01 | 25 |
| GCK 06-02 | 25 |
| GCK 08-01 | 25 |
| GCK 08-02 | 25 |
| GCK 08-03 | 25 |
| GCK 10-02 | 25 |
| GCK 10-03 | 25 |
| GCK 12-02 | 25 |
| GCK 12-03 | 25 |
| GCK 12-04 | 25 |

FCK - T - *UNION TEE*



Conico
Taper

| COD | 🛒 |
|-----------|----|
| FCK 04-01 | 25 |
| FCK 06-01 | 25 |
| FCK 06-02 | 25 |
| FCK 08-01 | 25 |
| FCK 08-02 | 25 |

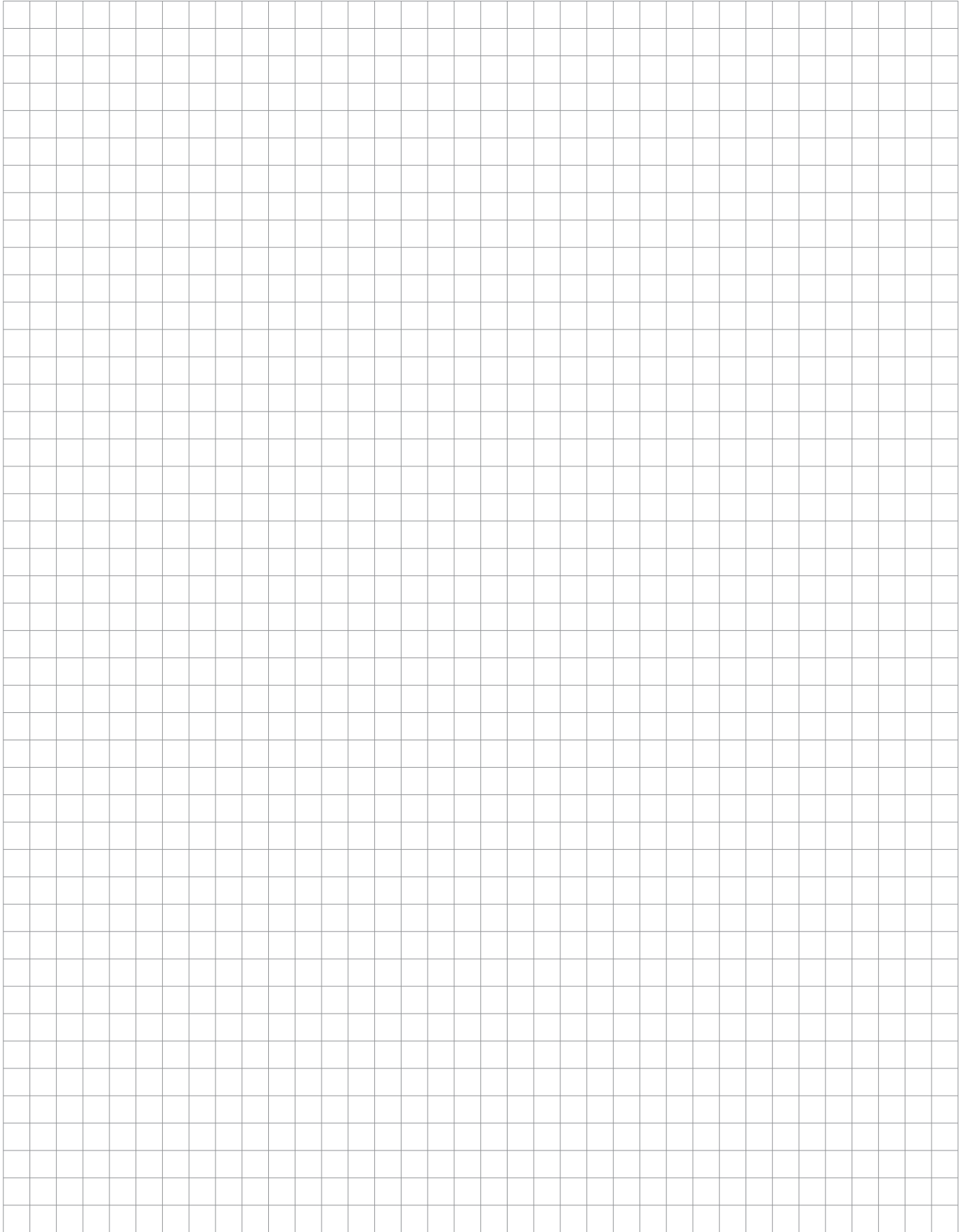



ACCESSORIES

| | | | | | |
|---|--------|-----|--|--------|-----|
|  | PAC-P | 120 |  | PET 48 | 120 |
|  | PAC-A | 120 |  | PET-A | 120 |
|  | PAC-B | 120 |  | PET-AL | 120 |
|  | PAC-C | 120 |  | PET-X | 120 |
|  | PAC-D | 120 |  | PET-XX | 120 |
|  | PAC-E | 120 |  | USP | 121 |
|  | PAC-M1 | 120 |  | PAR | 121 |
|  | PAC-M2 | 120 |  | UA | 121 |
|  | UC | 120 |  | UAF | 121 |
|  | UD | 120 |  | UMP | 121 |
|  | PET | 120 |  | RLF | 121 |

| | | | | | |
|---|--|-----|--|-------------|-----|
|  | UPP | 121 |  | MVS MM | 122 |
|  | UARX | 121 |  | MVS MF | 122 |
|  | NBP | 121 |  | MVS-MINI FF | 122 |
|  | UPT | 121 |  | MVS-MINI MM | 122 |
|  | UGC | 121 |  | MVS-MINI MF | 122 |
|  | VSR | 122 |  | MVS-MINI TT | 122 |
|  | MG POLIURETANO <i>MG</i> POLYURETHANE | 122 |  | MVS-POM-TT | 122 |
|  | MG VITON | 122 |  | MVX 02-04 | 123 |
|  | MG NBR | 122 |  | MVX 03-04 | 123 |
|  | MVS FF-X | 122 |  | MVX 04-04 | 123 |
|  | MVS FF | 122 |  | MVX 05-04 | 123 |

| | | | | | |
|---|-------------------|-----|--|---------|-----|
|  | MVX 06-04 | 123 |  | OS | 124 |
|  | VS LIBERE FREE | 124 |  | AM | 124 |
|  | VS FISSE FIXED | 124 |  | GPE | 124 |
|  | RSF | 124 |  | VP | 124 |
|  | TL | 124 |  | FL-MF | 125 |
|  | RSZ | 124 |  | FL-FF | 125 |
|  | VSC | 124 |  | FL-MM | 125 |
|  | VM | 124 |  | FLX-MM | 125 |
|  | TRP | 124 |  | FLX-MF | 125 |
|  | TANK 5L | 124 |  | FLX-FF | 125 |
|  | LAMA BLADE | 124 |  | FL-MINI | 125 |
| | | |  | DRIER | 125 |

| | | | | | |
|---|---------|-----|---|---|-----|
|  | RA | 125 |  | HVSS | 126 |
|  | RN | 125 |  | HVSF-A | 126 |
|  | RR | 125 |  | HVSF-B | 126 |
|  | RF | 125 |  | BC | 127 |
|  | RND | 126 |  | BC-S | 127 |
|  | PTS | 126 |  | BCL-X AISI 304 | 127 |
|  | VU-MF | 126 |  | STAFFA BRACKET | 127 |
|  | R-VU-TT | 126 |  | STA-X | 127 |
|  | VU-FF | 126 |  | BCQ | 128 |
|  | R-VU-MT | 126 |  | BCQ-S | 128 |
|  | HVFF | 126 |  | RIPARTITORI ALLUMINIO ANODIZZATO DISTRIBUTORS ANODIZED ALUMINIUM | 129 |

ACCESSORI - ACCESSORIES



| PAC-P | | |
|-------|------|---|
| COD | | |
| PAC-P | 1/4" | 1 |

Filetto 1/4" - F
Thread 1/4" - F



| PAC-A | | |
|-------|------|---|
| COD | | |
| PAC-A | 1/4" | 1 |

Filetto 1/4" - F
Thread 1/4" - F



| PAC-B | | |
|-------|------|---|
| COD | | |
| PAC-B | 1/4" | 1 |

Filetto 1/4" - F
Thread 1/4" - F



| PAC-C | | |
|-------|------|---|
| COD | | |
| PAC-C | 1/4" | 1 |

Pistola a norma OSHA 2,5 Bar - Filetto 1/4" - F
Standard gun OSHA 2,5 Bar - Thread 1/4" - F



| PAC-D | | |
|-------|------|---|
| COD | | |
| PAC-D | 1/4" | 1 |

Filetto 1/4" - F
Thread 1/4" - F



| PAC-E | | |
|-------|------|---|
| COD | | |
| PAC-E | 1/4" | 1 |

Filetto 1/4" - F
Thread 1/4" - F



| PAC-M1 | | |
|--------|------|---|
| COD | | |
| PAC-M1 | 1/8" | 1 |

Filetto 1/8"
Thread 1/8"



| PAC-M2 | | |
|--------|------|---|
| COD | | |
| PAC-M2 | 1/8" | 1 |

Filetto 1/8"
Thread 1/8"



| UC | | |
|--------------|--|---|
| COD | | |
| UCC L = 100 | | 5 |
| UCM L = 150 | | 5 |
| UCL L = 250 | | 5 |
| UCLL L = 400 | | 5 |

Tubo AISI 304
Pipe AISI 304

Filetti: 1/4" standard - M12 x 1,25 su richiesta
Threads: 1/4" standard - M12 x 1,25 on request



| UD | | |
|------------|--|---|
| COD | | |
| UDC L=100 | | 5 |
| UDM L=150 | | 5 |
| UDL L=250 | | 5 |
| UDLL L=400 | | 5 |

Tubo AISI 304
Pipe AISI 304

Filetti: 1/4" standard M12 x 1,25 su richiesta
Threads: 1/4" standard - M12 x 1,25 on request



| PET | | |
|-----|------|---|
| COD | | |
| PET | 1/4" | 5 |

Pettine soffiatore 1/4" Cilindrico - Resina acetaleica
Air blower comb 1/4" Parallel - Acetal resin



| PET-48 | | |
|--------|------|---|
| COD | | |
| PET-48 | 1/4" | 1 |

1/4" Cilindrico - ABS - Fori di uscita: 48
1/4" Parallel - ABS - 48 Exit holes



| PET-A | | |
|-------|------|---|
| COD | | |
| PET-A | 1/4" | 1 |

1/4" Cilindrico - Alluminio
1/4" Parallel - Aluminum



| PET-AL | | |
|--------|------|---|
| COD | | |
| PET-AL | 1/4" | 1 |

1/4" Cilindrico - Alluminio
1/4" Parallel - Aluminum



| PET-X | | |
|-------|------|---|
| COD | | |
| PET-X | 1/4" | 1 |

1/4" Cilindrico - AISI 316 L
1/4" Parallel - AISI 316 L



| PET-XX | | |
|--------|------|---|
| COD | | |
| PET-XX | 1/4" | 1 |

1/4" Cilindrico - AISI 316 L - Per alte pressioni
1/4" Parallel - AISI 316 L - For high pressures

ACCESSORI - ACCESORIES



| USP | | |
|-----|------|---|
| COD | | 🛒 |
| USP | 1/4" | 5 |

1/4" Cilindrico
Ugello di sicurezza a pettine - Resina acetalica
1/4" Parallel
Comb safety nozzle - Acetal resin



| PAR | | |
|-----|--|---|
| COD | | 🛒 |
| PAR | | 5 |

Parabola di protezione in ABS
Ugello UTC a richiesta
ABS Protection dish
UTC nozzle on request

| UA | | |
|-----|------|----|
| COD | | 🛒 |
| UA | 1/4" | 25 |

1/4" Cilindrico - Alluminio M12 x 1,25 su richiesta
1/4" Parallel - Aluminium M12 x 1,25 on request



| UAF | | |
|-----|------|----|
| COD | | 🛒 |
| UAF | 1/4" | 25 |

1/4" Cilindrico - Alluminio M12 x 1,25 su richiesta
1/4" Parallel - Aluminium M12 x 1,25 on request



| UMP | | |
|-----|--|---|
| COD | | 🛒 |
| UMP | | 1 |

Ugello multiplo per la pulizia tubi e serbatoi - Filetto 1/4"
Tanks and pipes cleaning nozzle - 1/4" Female



| RLF | | |
|-----|--|----|
| COD | | 🛒 |
| RLF | | 10 |

Regolatore in linea fisso 2,5 Bar - 1/4" Cilindrico + OR
1/4" Parallel + OR - In line 2,5 Bar Pressure Regulator



| UPP | | |
|-----|--|----|
| COD | | 🛒 |
| UPP | | 10 |

Ugello in ABS per asciugatura. Press. max 7 Bar - Filetto 1/4"
ABS nozzle for drying - Max pressure 7 Bar - Thread 1/4"



| UARX | | |
|------|--|---|
| COD | | 🛒 |
| UARX | | 1 |

Ugello ad alto rendimento - Abbattimento acustico: 40%
Materiale: AISI 316 L - Filetto 1/4"
High efficiency nozzle - Noise reduction: 40%
Material: AISI 316 L - Thread 1/4"



| NBP | | |
|-----|--|---|
| COD | | 🛒 |
| NBP | | 1 |

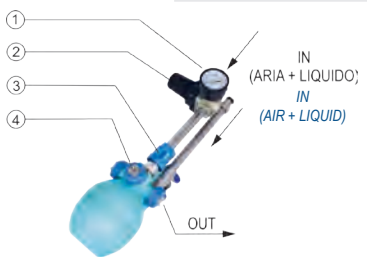

1 Manometro
2 Regolatore di pressione
3 Valvola a manicotto
4 Ugello spray (4 uscite)

1 Pressure gauge
2 Pressure Regulator
3 Pinch valve
4 Spray nozzle (4 outlets)

Sistema di nebulizzazione a bassa pressione - 220 / 110 VAC - 5 + 10 µ.
Il dispositivo copre una superficie da 30 mq a 40 mq. **Particolarmente adatto per la sanificazione di ambienti di lavoro, anche con ciclo programmato.**
Low pressure misting system - 220 / 110 VAC - 5 + 10 µ.
The device covers an area of 30 m² to 40 m². Particularly suitable for sanitization of work environments, even with a programmed cycle.

| UPT | | |
|-----|--|---|
| COD | | 🛒 |
| UPT | | 1 |



Ugello per la pulizia tubi - Avanzamento automatico sfruttando la pressione del getto (aria o liquido) - Pressione di esercizio 4 + 50 Bar
Pressione max 350 Bar - Temperatura max 180 °C

Nozzle for cleaning pipes - Automatic advance using the pressure of the jet (air or liquid) - Operating pressure 4 + 50 Bar
Pressione max 350 Bar - Max temperature 180 °C

| SUS | | |
|-----|--|---|
| COD | | 🛒 |
| SUS | | 1 |

Sistema di umidificazione e sanificazione
Dry fog humidification and sanification system

Descrizione ed informazioni prodotto: pag. 293
Product description and information: page 294



| UGC | | |
|-----|------|----|
| COD | | 🛒 |
| UGC | 1/4" | 10 |

Ugello a getto circolare per pulizia e verniciatura di piccoli serbatoi
Circular jet nozzle for cleaning and painting small tanks



ACCESSORI - ACCESSORIES

MG POLIURETANO - *MG POLYURETHANE*

| COD | | | |
|----------|------|--|----|
| MG 1 POL | 1/8" | | 10 |
| MG 2 POL | 1/4" | | 10 |
| MG 3 POL | 3/8" | | 10 |
| MG 4 POL | 1/2" | | 10 |
| MG 5 POL | 3/4" | | 10 |
| MG 6 POL | 1" | | 10 |
| MG 7 POL | M5 | | 10 |

VSR



| COD | | | |
|---------|-----------|--|----|
| 1 VSR | 1/8" | | 10 |
| 2 VSR | 1/4" | | 10 |
| 3 VSR | 3/8" | | 5 |
| 4 VSR | 1/2" | | 5 |
| 5 VSR | 3/4" | | 5 |
| 6 VSR | 1" | | 5 |
| 7 VSR | M5 | | 10 |
| 5 VSR-M | 3/4" MAXI | | 1 |
| 6 VSR-M | 1" MAXI | | 1 |

MG NBR



| COD | | | |
|-----------|-----------|--|----|
| MG 1 NBR | 1/8" | | 10 |
| MG 2 NBR | 1/4" | | 10 |
| MG 3 NBR | 3/8" | | 10 |
| MG 4 NBR | 1/2" | | 10 |
| MG 5 NBR | 3/4" | | 10 |
| MG 6 NBR | 1" | | 10 |
| MG 7 NBR | M5 | | 10 |
| MG M5 NBR | 3/4" MAXI | | 10 |
| MG M6 NBR | 1" MAXI | | 10 |

MG VITON



Lotti minimi
da concordare
*Minimum lots
to be agreed*

| COD | | | |
|-------------|-----------|--|----|
| MG 1 VITON | 1/8" | | 10 |
| MG 2 VITON | 1/4" | | 10 |
| MG 3 VITON | 3/8" | | 10 |
| MG 4 VITON | 1/2" | | 10 |
| MG 5 VITON | 3/4" | | 10 |
| MG 7 VITON | M5 | | 10 |
| MG-M5 VITON | 3/4" MAXI | | 10 |
| MG-M6 VITON | 1" MAXI | | 10 |

MVS FF-X

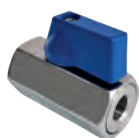

AISI 316 L

| COD | | | |
|------------|------|--|----|
| 1 MVS FF-X | 1/8" | | 10 |
| 2 MVS FF-X | 1/4" | | 10 |
| 3 MVS FF-X | 3/8" | | 10 |
| 4 MVS FF-X | 1/2" | | 10 |
| 5 MVS FF-X | 3/4" | | 10 |
| 6 MVS FF-X | 1" | | 10 |

Colore Maniglia: blu
Handle color: blue

MVS FF

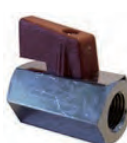

| COD | | | |
|----------|------|--|----|
| 1 MVS FF | 1/8" | | 10 |
| 2 MVS FF | 1/4" | | 10 |
| 3 MVS FF | 3/8" | | 10 |
| 4 MVS FF | 1/2" | | 10 |
| 5 MVS FF | 3/4" | | 10 |

Maniglia rossa: Standard - Maniglia nera: su richiesta
Red Handle: Standard - Black Handle: on request

MVS MM



Cilindrico
Parallel

| COD | | | |
|----------|------|--|----|
| 1 MVS MM | 1/8" | | 10 |
| 2 MVS MM | 1/4" | | 10 |
| 3 MVS MM | 3/8" | | 10 |
| 4 MVS MM | 1/2" | | 10 |

Maniglia rossa: Standard - Maniglia nera: su richiesta
Red Handle: Standard - Black Handle: on request

MVS MF



Cilindrico
Parallel

| COD | | | |
|----------|------|--|----|
| 1 MVS MF | 1/8" | | 10 |
| 2 MVS MF | 1/4" | | 10 |
| 3 MVS MF | 3/8" | | 10 |
| 4 MVS MF | 1/2" | | 10 |
| 5 MVS MF | 3/4" | | 10 |

Maniglia rossa: Standard - Maniglia nera: su richiesta
Red Handle: Standard - Black Handle: on request

MVS-MINI FF



| COD | | | |
|---------------|------|--|----|
| 1 MVS-MINI FF | 1/8" | | 10 |
| 2 MVS-MINI FF | 1/4" | | 10 |
| 3 MVS-MINI FF | 3/8" | | 10 |
| 4 MVS-MINI FF | 1/2" | | 10 |

MVS-MINI MM



| COD | | | |
|---------------|------|--|----|
| 1 MVS-MINI MM | 1/8" | | 10 |
| 2 MVS-MINI MM | 1/4" | | 10 |
| 3 MVS-MINI MM | 3/8" | | 10 |
| 4 MVS-MINI MM | 1/2" | | 10 |

MVS-MINI MF



| COD | | | |
|---------------|------|--|----|
| 1 MVS-MINI MF | 1/8" | | 10 |
| 2 MVS-MINI MF | 1/4" | | 10 |
| 3 MVS-MINI MF | 3/8" | | 10 |
| 4 MVS-MINI MF | 1/2" | | 10 |

MVS-MINI TT



| COD | | | |
|---------------|-----|--|----|
| 1 MVS-MINI TT | 4-4 | | 10 |
| 2 MVS-MINI TT | 6-6 | | 10 |
| 3 MVS-MINI TT | 8-8 | | 10 |

MVS-MINI MT



| COD | | | |
|---------------|--------|--|----|
| 1 MVS-MINI MT | 4-1/8" | | 10 |
| 2 MVS-MINI MT | 4-1/4" | | 10 |
| 3 MVS-MINI MT | 6-1/8" | | 10 |
| 4 MVS-MINI MT | 6-1/4" | | 10 |
| 5 MVS-MINI MT | 8-1/8" | | 10 |
| 6 MVS-MINI MT | 8-1/4" | | 10 |

MVS-POM-TT



| COD | | | |
|--------------|-------|--|----|
| 1 MVS-POM-TT | 4-4 | | 10 |
| 2 MVS-POM-TT | 6-6 | | 10 |
| 3 MVS-POM-TT | 8-8 | | 10 |
| 4 MVS-POM-TT | 10-10 | | 10 |

Materiale: Tecnopolimero
Material: Plastic

MINI VALVOLE INOX - *STAINLESS STEEL MINI VALVES*



AISI 304

MINI VALVOLE A SFERA 2 VIE AISI 304 - *AISI 304 2-WAY MINI BALL VALVES*



AISI 304

| COD | CARATTERISTICHE - <i>FEATURES</i> | |
|---|-----------------------------------|---|
| MVX 02-04 | 2 VIE - <i>2 WAYS</i> | 1 |
| Per tubo 4 - <i>For tube 4</i> | | |
| Massima temperatura di esercizio - <i>Maximum operating temperature</i> : 40 °C | | |
| Massima pressione di esercizio - <i>Maximum operating pressure</i> : 4 Bar | | |

MINI VALVOLE A SFERA 3 VIE AISI 304 - *AISI 304 3-WAY MINI BALL VALVES*



AISI 304

| COD | CARATTERISTICHE - <i>FEATURES</i> | |
|---|-----------------------------------|---|
| MVX 03-04 | 3 VIE - <i>3 WAYS</i> | 1 |
| Per tubo 4 - <i>For tube 4</i> | | |
| Massima temperatura di esercizio - <i>Maximum operating temperature</i> : 40 °C | | |
| Massima pressione di esercizio - <i>Maximum operating pressure</i> : 4 Bar | | |

MINI VALVOLE A SFERA 4 VIE AISI 304 - *AISI 304 4-WAY MINI BALL VALVES*



AISI 304

| COD | CARATTERISTICHE - <i>FEATURES</i> | |
|---|-----------------------------------|---|
| MVX 04-04 | 4 VIE - <i>4 WAYS</i> | 1 |
| Per tubo 4 - <i>For tube 4</i> | | |
| Massima temperatura di esercizio - <i>Maximum operating temperature</i> : 40 °C | | |
| Massima pressione di esercizio - <i>Maximum operating pressure</i> : 4 Bar | | |

MINI VALVOLE A SFERA 5 VIE AISI 304 - *AISI 304 5-WAY MINI BALL VALVES*



AISI 304

| COD | CARATTERISTICHE - <i>FEATURES</i> | |
|---|-----------------------------------|---|
| MVX 05-04 | 5 VIE - <i>5 WAYS</i> | 1 |
| Per tubo 4 - <i>For tube 4</i> | | |
| Massima temperatura di esercizio - <i>Maximum operating temperature</i> : 40 °C | | |
| Massima pressione di esercizio - <i>Maximum operating pressure</i> : 4 Bar | | |

MINI VALVOLE A SFERA 6 VIE AISI 304 - *AISI 304 6-WAY MINI BALL VALVES*



AISI 304

| COD | CARATTERISTICHE - <i>FEATURES</i> | |
|---|-----------------------------------|---|
| MVX 06-04 | 6 VIE - <i>6 WAYS</i> | 1 |
| Per tubo 4 - <i>For tube 4</i> | | |
| Massima temperatura di esercizio - <i>Maximum operating temperature</i> : 40 °C | | |
| Massima pressione di esercizio - <i>Maximum operating pressure</i> : 4 Bar | | |

ACCESSORI - ACCESSORIES

VS LIBERE - FREE



| COD | | 🛒 |
|------|-------------------------------|----|
| 1 VS | 1/8" : 0,5 - 5, 6 -12, 13 -18 | 10 |
| 2 VS | 1/4" : 0,5 - 5, 6 -12, 13 -18 | 10 |
| 3 VS | 3/8" : 0,5 - 5, 6 -12, 13 -18 | 10 |
| 4 VS | 1/2" : 0,5 - 5, 6 -12, 13 -18 | 10 |
| 5 VS | 3/4" : 0,5 - 5, 6 -12, 13 -18 | 5 |
| 6 VS | 1" : 0,5 - 5, 6 -12, 13 -18 | 5 |

Cilindrico - *Parallel*Valvole di sicurezza libere - *Free safety valves*

VS FISSE - FIXED



| COD | | 🛒 |
|------|--------------|----|
| 1 VS | 1/8" : 0 -18 | 10 |
| 2 VS | 1/4" : 0 -18 | 10 |
| 3 VS | 3/8" : 0 -18 | 10 |
| 4 VS | 1/2" : 0 -18 | 10 |
| 5 VS | 3/4" : 0 -18 | 5 |
| 6 VS | 1" : 0 -18 | 5 |

Cilindrico - *Parallel*Valvole di sicurezza tarate non certificate - Tarate su richiesta
Calibrated non-certified safety valves - Calibrated on request

RSF



| COD | | 🛒 |
|-------|------|----|
| 2 RSF | 1/4" | 25 |
| 3 RSF | 3/8" | 25 |
| 4 RSF | 1/2" | 25 |

Cilindrico - *Parallel*Rubinetto di spurgo - *Drain valve*

TL



| COD | | 🛒 |
|-------|---------|----|
| 2 TL | 1/4" | 25 |
| 3 TL | 3/8" | 25 |
| 4 TL | 1/2" | 10 |
| 5 TL | 3/4" | 10 |
| 6 TL | 1" | 5 |
| 11 TL | 1"-1/4" | 5 |

Cilindrico - *Parallel*Materiale: corpo in alluminio 11S visore in TROGRAMID T
Pressione Max: 10 Bar - Temperatura: -30 °C + 100 °C
Body: Aluminium 11S - Visual level indicator TROGRAMID T
Pressure Max: 10 Bar - Temperature: -30 °C + 100 °C

RSZ



| COD | | 🛒 |
|-------|------|----|
| 1 RSZ | 1/8" | 25 |
| 2 RSZ | 1/4" | 25 |
| 3 RSZ | 3/8" | 25 |
| 4 RSZ | 1/2" | 25 |

Cilindrico - *Parallel*Rubinetto di spurgo - *Drain valve*

VSC



| COD | | 🛒 |
|-------|------|----|
| 2 VSC | 1/4" | 25 |

Cilindrico - *Parallel*Valvola di scarico condensa - *Drain valve*

VM

Valvola manicotto
Slide valve

| COD | | 🛒 |
|------|------|----|
| 1 VM | 1/8" | 10 |
| 2 VM | 1/4" | 10 |
| 3 VM | 3/8" | 10 |
| 4 VM | 1/2" | 10 |
| 5 VM | 3/4" | 10 |
| 7 VM | M5 | 10 |

TRP



| COD | | 🛒 |
|-------|--|---|
| 1 TRP | | 1 |

Avvisatore acustico pneumatico - *Pneumatic horn*

TANK 5L



| COD | | 🛒 |
|---------|--|---|
| TANK 5L | | 1 |

Interno decapato + trattamento antiruggine
Internally painted anti-rust

LAMA - BLADE

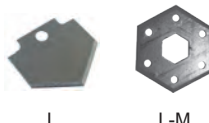

| COD | | 🛒 |
|-----|--|----|
| L | | 50 |
| L-M | | 50 |

Lama ricambio - *Spare blade*

OS



| COD | | 🛒 |
|------|------|----|
| 1 OS | 1/8" | 25 |
| 2 OS | 1/4" | 25 |
| 3 OS | 3/8" | 10 |
| 4 OS | 1/2" | 0 |
| 5 OS | 3/4" | 5 |
| 6 OS | 1" | 5 |

Orientatore in Nylon - *Nylon cap for SOS Silencer*

AM - SMORZATORI - DAMPERS



| COD | | 🛒 |
|------|------------------------------------|----|
| 1 AM | 1/8" : B=0-20, M=20-100, A>100 Bar | 25 |
| 2 AM | 1/4" : B=0-20, M=20-100, A>100 Bar | 25 |
| 3 AM | 3/8" : B=0-20, M=20-100, A>100 Bar | 25 |
| 4 AM | 1/2" : B=0-20, M=20-100, A>100 Bar | 25 |

Cilindrico - *Parallel*

VP

VALVOLE A PEDALE
*FOOT VALVES*Elenco completo delle valvole: pag. 216
Complete list of valves: page. 216🛒
1

GPE

GENERATORE PNEUMO ELETTRICO
*ELECTRIC PNEUMATIC GENERATOR*Descrizione ed informazioni prodotto: pag. 296
Product description and information: page 296🛒
1

FL-MF



| COD | | 🛒 |
|---------|------|----|
| 1 FL-MF | 1/8" | 25 |
| 2 FL-MF | 1/4" | 25 |
| 3 FL-MF | 3/8" | 25 |
| 4 FL-MF | 1/2" | 25 |
| 5 FL-MF | 3/4" | 10 |
| 6 FL-MF | 1" | 10 |
| 7 FL-MF | M5 | 25 |

Filtro in linea - Cilindrico
Inline filter - Parallel

FL-FF



| COD | | 🛒 |
|---------|------|----|
| 1 FL-FF | 1/8" | 25 |
| 2 FL-FF | 1/4" | 25 |
| 3 FL-FF | 3/8" | 25 |
| 4 FL-FF | 1/2" | 25 |
| 5 FL-FF | 3/4" | 10 |
| 6 FL-FF | 1" | 10 |
| 7 FL-FF | M5 | 25 |

Filtro in linea
Inline filter

FL-MM



| COD | | 🛒 |
|---------|------|----|
| 1 FL-MM | 1/8" | 25 |
| 2 FL-MM | 1/4" | 25 |

Filtro in linea - Ottone nichelato - Cilindrico
Inline filter - Nickel plated brass - Parallel

FLX-MM



| COD | | 🛒 |
|----------|------|----|
| 1 FLX-MM | 1/8" | 25 |
| 2 FLX-MM | 1/4" | 25 |

Filtro in linea - Cilindrico - AISI 316
Inline filter - Parallel - AISI 316

FLX-MF



| COD | | 🛒 |
|----------|------|----|
| 1 FLX-MF | 1/8" | 10 |
| 2 FLX-MF | 1/4" | 10 |
| 3 FLX-MF | 3/8" | 10 |
| 4 FLX-MF | 1/2" | 10 |

Filtro in linea - Cilindrico - AISI 316
Inline filter - Parallel - AISI 316

FLX-FF



| COD | | 🛒 |
|----------|------|----|
| 1 FLX-FF | 1/8" | 10 |
| 2 FLX-FF | 1/4" | 10 |
| 3 FLX-FF | 3/8" | 10 |
| 4 FLX-FF | 1/2" | 10 |

Filtro in linea - AISI 316
Inline filter - AISI 316

FL-MINI



| COD | | 🛒 |
|---------|-----|----|
| FL-MINI | Ø 3 | 25 |
| FL-MINI | Ø 5 | 25 |

Filtro in resina acetica - Acetal resin filter

DRIER



| COD | | 🛒 |
|----------|------------|---|
| DRIER | - DRIER | 5 |
| KIT SALI | - SALT KIT | 5 |

1/4" Cilindrico - 1/4" Parallel

RA



| COD | | 🛒 |
|-------|---------|-----|
| 1 RA | 1/8" | 100 |
| 2 RA | 1/4" | 100 |
| 3 RA | 3/8" | 100 |
| 4 RA | 1/2" | 100 |
| 5 RA | 3/4" | 100 |
| 6 RA | 1" | 100 |
| 7 RA | M5 | 100 |
| 11 RA | 1" 1/4" | 50 |
| 12 RA | 1" 1/2" | 50 |
| 13 RA | 2" | 50 |

Alluminio - Aluminium

RN



| COD | | 🛒 |
|-------|---------|-----|
| 1 RN | 1/8" | 100 |
| 2 RN | 1/4" | 100 |
| 3 RN | 3/8" | 100 |
| 4 RN | 1/2" | 100 |
| 5 RN | 3/4" | 100 |
| 6 RN | 1" | 100 |
| 7 RN | M5 | 100 |
| 11 RN | 1" 1/4" | 50 |
| 12 RN | 1" 1/2" | 50 |
| 13 RN | 2" | 50 |

Nylon
Colore standard: Bianco
Colore Blu - Nero: +10%

Nylon
Standard: White
Blue - Black: +10%

RR



| COD | | 🛒 |
|-------|---------|-----|
| 1 RR | 1/8" | 100 |
| 2 RR | 1/4" | 100 |
| 3 RR | 3/8" | 100 |
| 4 RR | 1/2" | 100 |
| 5 RR | 3/4" | 100 |
| 6 RR | 1" | 100 |
| 7 RR | M5 | 100 |
| 11 RR | 1" 1/4" | 50 |
| 12 RR | 1" 1/2" | 50 |
| 13 RR | 2" | 50 |

Rame - Copper

RF



| COD | | 🛒 |
|-------|---------|-----|
| 1 RF | 1/8" | 100 |
| 2 RF | 1/4" | 100 |
| 3 RF | 3/8" | 100 |
| 4 RF | 1/2" | 100 |
| 5 RF | 3/4" | 100 |
| 6 RF | 1" | 100 |
| 7 RF | M5 | 100 |
| 11 RF | 1" 1/4" | 50 |
| 12 RF | 1" 1/2" | 50 |
| 13 RF | 2" | 50 |

Fibra - Fiber

ACCESSORI - ACCESSORIES

RND



| COD | | 🛒 |
|-------|------|-----|
| 1 RND | 1/8" | 100 |
| 2 RND | 1/4" | 100 |
| 3 RND | 3/8" | 100 |
| 4 RND | 1/2" | 100 |
| 5 RND | 3/4" | 100 |
| 6 RND | 1" | 100 |
| 7 RND | M5 | 100 |
| 8 RND | M6 | 100 |

Nylon con dentini - Colore standard: Blu - A richiesta: Nero
 Nylon notched washer - Blue color: standard - Black color: on request

PTS - MINI TAGLIA TUBO - MINI TUBE CUTTER



| COD | 🛒 |
|-----|---|
| PTS | 5 |

Mini taglia tubo - Lama in AISI 316
 Mini pipe cutter - AISI 316 blade

VALVOLE UNIDIREZIONALI - CHECK VALVES

VU-MF



Cilindrico - Parallel

| COD | | 🛒 |
|---------|------|----|
| 1 VU-MF | 1/8" | 25 |
| 2 VU-MF | 1/4" | 25 |
| 3 VU-MF | 3/8" | 25 |
| 4 VU-MF | 1/2" | 25 |
| 7 VU-MF | M5 | 25 |

R-VU-TT



| COD | | 🛒 |
|-----------|---------|----|
| 1 R-VU-TT | 4 - 4 | 25 |
| 2 R-VU-TT | 6 - 6 | 25 |
| 3 R-VU-TT | 8 - 8 | 25 |
| 4 R-VU-TT | 10 - 10 | 25 |
| 5 R-VU-TT | 12 - 12 | 25 |

VU-FF



Cilindrico - Parallel

| COD | | 🛒 |
|---------|------|----|
| 1 VU-FF | 1/8" | 25 |
| 2 VU-FF | 1/4" | 25 |
| 3 VU-FF | 3/8" | 25 |
| 4 VU-FF | 1/2" | 25 |
| 5 VU-FF | 3/4" | 25 |
| 6 VU-FF | 1" | 25 |
| 7 VU-FF | M5 | 25 |

R-VU-MT



| COD | | 🛒 |
|------------|---------|----|
| 1 R-VU-MT | 4 M5 | 25 |
| 2 R-VU-MT | 4 1/8" | 25 |
| 3 R-VU-MT | 6 1/8" | 25 |
| 4 R-VU-MT | 6 1/4" | 25 |
| 5 R-VU-MT | 8 1/8" | 25 |
| 6 R-VU-MT | 8 1/4" | 25 |
| 7 R-VU-MT | 10 1/4" | 25 |
| 8 R-VU-MT | 10 3/8" | 25 |
| 9 R-VU-MT | 12 1/2" | 25 |
| 10 R-VU-MT | 14 1/2" | 25 |

VALVOLE A 2 VIE - 2 WAYS VALVE

HVFF



2 VIE - 2 WAYS

| COD | | 🛒 |
|------|---------|----|
| HVFF | 4 - 4 | 10 |
| HVFF | 6 - 6 | 10 |
| HVFF | 8 - 6 | 10 |
| HVFF | 8 - 8 | 10 |
| HVFF | 10 - 10 | 10 |
| HVFF | 12 - 10 | 10 |
| HVFF | 12 - 12 | 10 |

HVSS



Conico Tefonato - 2 VIE
 Taper - 2 WAYS

| COD | | 🛒 |
|------|-------------|----|
| HVSS | 1/8" - 1/8" | 10 |
| HVSS | 1/4" - 1/8" | 10 |
| HVSS | 1/4" - 1/4" | 10 |
| HVSS | 3/8" - 1/4" | 10 |
| HVSS | 3/8" - 3/8" | 10 |
| HVSS | 1/2" - 3/8" | 10 |
| HVSS | 1/2" - 1/2" | 10 |

HVSF-A



Conico Tefonato - 2 VIE
 Taper - 2 WAYS

| COD | | 🛒 |
|--------|-----------|----|
| HVSF-A | 6 - 1/8" | 10 |
| HVSF-A | 6 - 1/4" | 10 |
| HVSF-A | 6 - 3/8" | 10 |
| HVSF-A | 8 - 1/8" | 10 |
| HVSF-A | 8 - 1/4" | 10 |
| HVSF-A | 8 - 3/8" | 10 |
| HVSF-A | 10 - 1/4" | 10 |
| HVSF-A | 10 - 3/8" | 10 |
| HVSF-A | 10 - 1/2" | 10 |
| HVSF-A | 12 - 1/4" | 10 |
| HVSF-A | 12 - 3/8" | 10 |
| HVSF-A | 12 - 1/2" | 10 |

← FLOW

HVSF-B



Conico Tefonato - 2 VIE
 Taper - 2 WAYS

| COD | | 🛒 |
|--------|-----------|----|
| HVSF-B | 6 - 1/8" | 10 |
| HVSF-B | 6 - 1/4" | 10 |
| HVSF-B | 6 - 3/8" | 10 |
| HVSF-B | 8 - 1/8" | 10 |
| HVSF-B | 8 - 1/4" | 10 |
| HVSF-B | 8 - 3/8" | 10 |
| HVSF-B | 10 - 1/4" | 10 |
| HVSF-B | 10 - 3/8" | 10 |
| HVSF-B | 10 - 1/2" | 10 |
| HVSF-B | 12 - 1/4" | 10 |
| HVSF-B | 12 - 3/8" | 10 |
| HVSF-B | 12 - 1/2" | 10 |

→ FLOW

ACCESSORI - *ACCESORIES*SERBATOI - *TANKS*

BC



| COD | | | 🛒 |
|--------|---------|-----------------|---|
| 0,5 BC | 0,5 lt | 2 uscite/outlet | 1 |
| 1 BC | 1,0 lt | 2 uscite/outlet | 1 |
| 2,5 BC | 2,5 lt | 2 uscite/outlet | 1 |
| 5 BC | 5,0 lt | 2 uscite/outlet | 1 |
| 7 BC | 7,0 lt | 2 uscite/outlet | 1 |
| 12 BC | 12,0 lt | 2 uscite/outlet | 1 |
| 18 BC | 18,0 lt | 2 uscite/outlet | 1 |
| 24 BC | 24,0 lt | 2 uscite/outlet | 1 |

CARATTERISTICHE
 Conformi alla direttiva 97/23/CE
 5-7-12 BC-S completi di marchio CE
 Decapaggio su richiesta + 20%

TECHNICAL FEATURES
 According to 97/23/CE directive
 5-7-12 BC-S types with CE mark
 Pickling on request + 20%

A RICHIESTA: Interno decappato e trattato antiruggine - *ON REQUEST: Pickled interior and anti-rust treated*

BC-S



| COD | | | 🛒 |
|----------|---------|-----------------|---|
| 1 BC-S | 1,0 lt | 4 uscite/outlet | 1 |
| 2,5 BC-S | 2,5 lt | 4 uscite/outlet | 1 |
| 5 BC-S | 5,0 lt | 4 uscite/outlet | 1 |
| 7 BC-S | 7,0 lt | 4 uscite/outlet | 1 |
| 12 BC-S | 12,0 lt | 4 uscite/outlet | 1 |
| 18 BC-S | 18,0 lt | 4 uscite/outlet | 1 |
| 24 BC-S | 24,0 lt | 4 uscite/outlet | 1 |

CARATTERISTICHE
 Conformi alla direttiva 97/23/CE
 5-7-12 BC-S completi di marchio CE
 Decapaggio su richiesta + 20%

TECHNICAL FEATURES
 According to 97/23/CE directive
 5-7-12 BC-S types with CE mark
 Pickling on request + 20%

A RICHIESTA: Interno decappato e trattato antiruggine - *ON REQUEST: Pickled interior and anti-rust treated*

BCL-X AISI 304



AISI 304
 AISI 304

| COD | | | 🛒 |
|-----------|---------|--|---|
| 1 BCL-X | 1,0 lt | | 1 |
| 2 BCL-X | 2,0 lt | | 1 |
| 4 BCL-X | 4,5 lt | | 1 |
| 5 BCL-X | 5,0 lt | | 1 |
| 8,5 BCL-X | 8,5 lt | | 1 |
| 12 BCL-X | 12,0 lt | | 1 |
| 15 BCL-X | 15,0 lt | | 1 |
| 24 BCL-X | 24,0 lt | | 1 |
| 30 BCL-X | 29,0 lt | | 1 |
| 50 BCL-X | 50,0 lt | | 1 |

CARATTERISTICHE
 Conformi alla direttiva 97/23/CE
 5-7-12 BC-S completi di marchio CE
 Decapaggio su richiesta + 20%

TECHNICAL FEATURES
 According to 97/23/CE directive
 5-7-12 BC-S types with CE mark
 Pickling on request + 20%

STAFFA - *BRACKET*

| COD | 🛒 |
|-------------------------|---|
| STAFFA - <i>BRACKET</i> | 1 |

Acciaio (vernice epossidica)
Steel (epoxy painted)

STA-X



| COD | 🛒 |
|-------|---|
| STA-X | 1 |

AISI 304 - AISI 304



INTERNO DECAPATO + TRATTAMENTO ANTIRUGGINE
 (LISTINO + 20%)
INTERNALLY PAINTED ANTI-RUST
 (PRICELIST + 20%)

ACCESSORI - ACCESSORIES

SERBATOI - TANKS

BCQ



| COD | | | 🛒 |
|--------|---------|-----------------|---|
| 1 BCQ | 1,0 lt | 2 uscite/outlet | 1 |
| 2 BCQ | 2,0 lt | 2 uscite/outlet | 1 |
| 4 BCQ | 4,0 lt | 2 uscite/outlet | 1 |
| 6 BCQ | 6,0 lt | 2 uscite/outlet | 1 |
| 8 BCQ | 8,0 lt | 2 uscite/outlet | 1 |
| 10 BCQ | 10,0 lt | 2 uscite/outlet | 1 |
| 12 BCQ | 12,0 lt | 2 uscite/outlet | 1 |

CARATTERISTICHE
Conformi alla direttiva 97/23/CE
5-7-12 BC-S completi di marchio CE

TECHNICAL FEATURES
According to 97/23/CE directive
5-7-12 types with CE mark

BCQ-S



| COD | | | 🛒 |
|----------|---------|-----------------|---|
| 1 BCQ-S | 1,0 lt | 4 uscite/outlet | 1 |
| 2 BCQ-S | 2,0 lt | 4 uscite/outlet | 1 |
| 4 BCQ-S | 4,0 lt | 4 uscite/outlet | 1 |
| 6 BCQ-S | 6,0 lt | 4 uscite/outlet | 1 |
| 8 BCQ-S | 8,0 lt | 4 uscite/outlet | 1 |
| 10 BCQ-S | 10,0 lt | 4 uscite/outlet | 1 |
| 12 BCQ-S | 12,0 lt | 4 uscite/outlet | 1 |

CARATTERISTICHE
Conformi alla direttiva 97/23/CE
5-7-12 BC-S completi di marchio CE

TECHNICAL FEATURES
According to 97/23/CE directive
5-7-12 types with CE mark

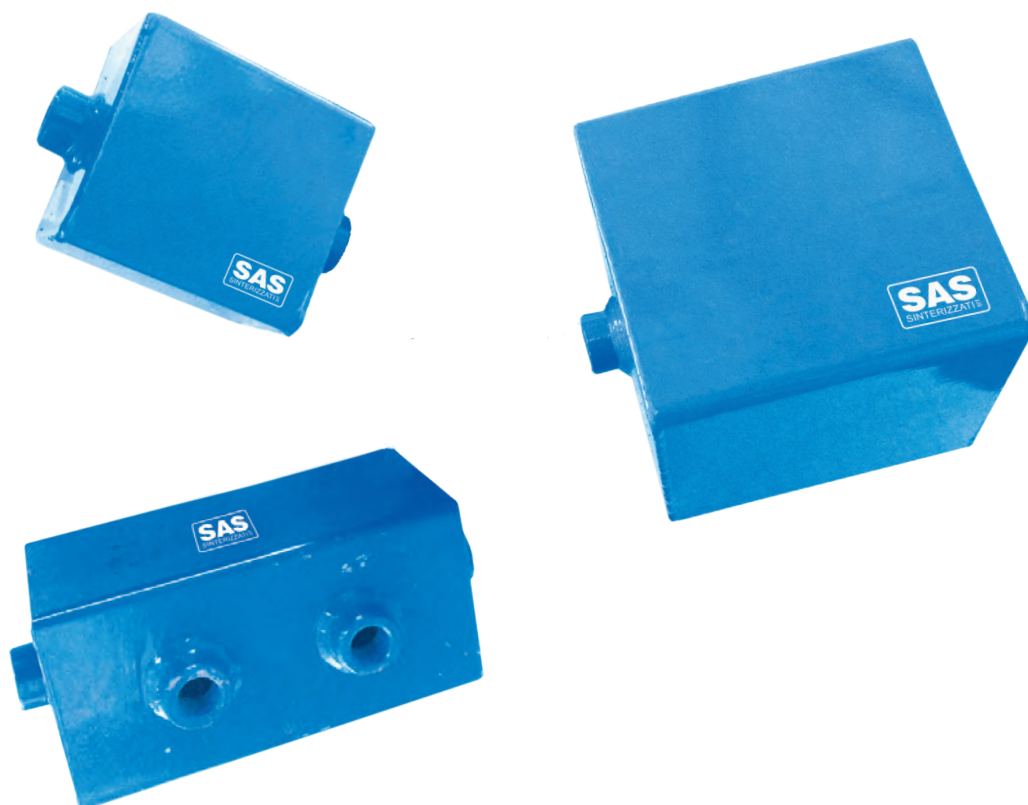

RIPARTITORI IN ALLUMINIO ANODIZZATO - *DISTRIBUTORS IN ANODIZED ALUMINIUM*

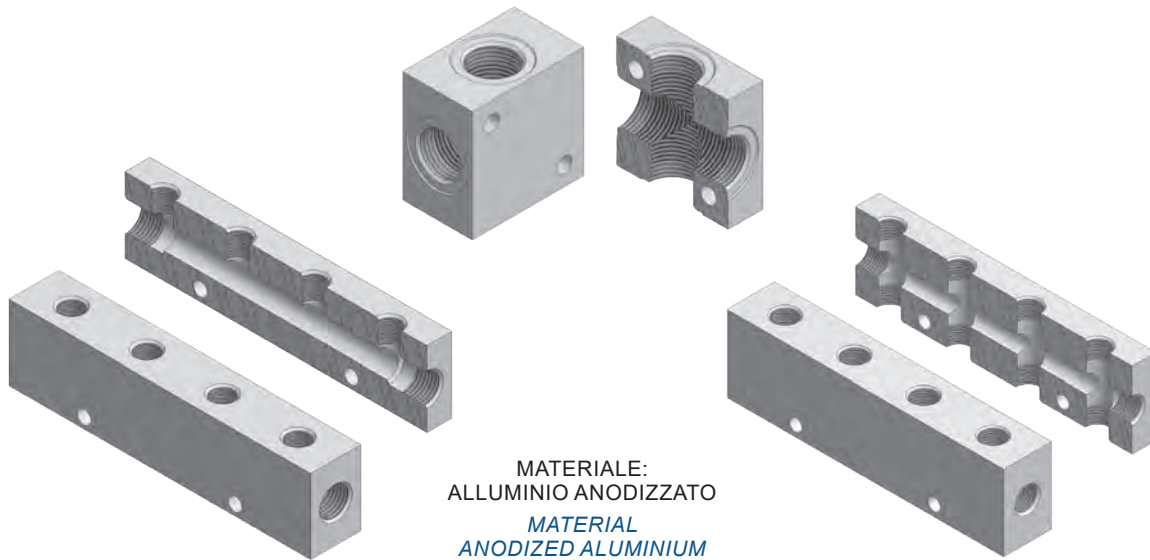

RIPARTITORE CON USCITE LINEARI - *DIVIDER WITH LINEAR OUTPUTS*

| COD | FORI USCITA <i>EXIT HOLES</i> | FORI INGRESSO <i>INLET HOLES</i> | 🛒 |
|-------------|----------------------------------|-------------------------------------|----|
| 1 RUL M5 | 2 FORI- <i>HOLES</i> M5 | 1/8" | 10 |
| 2 RUL M5 | 3 FORI- <i>HOLES</i> M5 | 1/8" | 10 |
| 3 RUL M5 | 4 FORI- <i>HOLES</i> M5 | 1/8" | 10 |
| 4 RUL M5 | 5 FORI- <i>HOLES</i> M5 | 1/8" | 10 |
| 5 RUL M5 | 6 FORI- <i>HOLES</i> M5 | 1/8" | 10 |
| 6 RUL 1/8" | 2 FORI- <i>HOLES</i> 1/8" | 1/4" | 10 |
| 7 RUL 1/8" | 3 FORI- <i>HOLES</i> 1/8" | 1/4" | 10 |
| 8 RUL 1/8" | 4 FORI- <i>HOLES</i> 1/8" | 1/4" | 10 |
| 9 RUL 1/8" | 5 FORI- <i>HOLES</i> 1/8" | 1/4" | 10 |
| 10 RUL 1/8" | 6 FORI- <i>HOLES</i> 1/8" | 1/4" | 10 |
| 11 RUL 1/4" | 2 FORI- <i>HOLES</i> 1/4" | 3/8" | 10 |
| 12 RUL 1/4" | 3 FORI- <i>HOLES</i> 1/4" | 3/8" | 10 |
| 13 RUL 1/4" | 4 FORI- <i>HOLES</i> 1/4" | 3/8" | 10 |
| 14 RUL 1/4" | 5 FORI- <i>HOLES</i> 1/4" | 3/8" | 10 |
| 15 RUL 1/4" | 6 FORI- <i>HOLES</i> 1/4" | 3/8" | 10 |
| 16 RUL 1/4" | 2 FORI- <i>HOLES</i> 1/4" | 1/2" | 10 |
| 17 RUL 1/4" | 3 FORI- <i>HOLES</i> 1/4" | 1/2" | 10 |
| 18 RUL 1/4" | 4 FORI- <i>HOLES</i> 1/4" | 1/2" | 10 |
| 19 RUL 1/4" | 5 FORI- <i>HOLES</i> 1/4" | 1/2" | 10 |
| 20 RUL 1/4" | 6 FORI- <i>HOLES</i> 1/4" | 1/2" | 10 |
| 21 RUL 3/8" | 2 FORI- <i>HOLES</i> 3/8" | 1/2" | 10 |
| 22 RUL 3/8" | 3 FORI- <i>HOLES</i> 3/8" | 1/2" | 10 |
| 23 RUL 3/8" | 4 FORI- <i>HOLES</i> 3/8" | 1/2" | 10 |
| 24 RUL 3/8" | 5 FORI- <i>HOLES</i> 3/8" | 1/2" | 10 |
| 25 RUL 3/8" | 6 FORI- <i>HOLES</i> 3/8" | 1/2" | 10 |
| 26 RUL 1/2" | 2 FORI- <i>HOLES</i> 1/2" | 1/2" | 10 |
| 27 RUL 1/2" | 3 FORI- <i>HOLES</i> 1/2" | 1/2" | 10 |
| 28 RUL 1/2" | 4 FORI- <i>HOLES</i> 1/2" | 1/2" | 10 |
| 29 RUL 1/2" | 5 FORI- <i>HOLES</i> 1/2" | 1/2" | 10 |
| 30 RUL 1/2" | 6 FORI- <i>HOLES</i> 1/2" | 1/2" | 10 |

RIPARTITORE CON USCITE CONTRAPPOSTE - *DISTRIBUTOR WITH OPPOSING OUTPUTS*

| COD | FORI USCITA <i>EXIT HOLES</i> | FORI INGRESSO <i>INLET HOLES</i> | 🛒 |
|-------------|----------------------------------|-------------------------------------|----|
| 1 RUC M5 | 2+2 FORI- <i>HOLES</i> M5 | 1/8" | 10 |
| 2 RUC M5 | 3+3 FORI- <i>HOLES</i> M5 | 1/8" | 10 |
| 3 RUC M5 | 4+4 FORI- <i>HOLES</i> M5 | 1/8" | 10 |
| 4 RUC M5 | 5+5 FORI- <i>HOLES</i> M5 | 1/8" | 10 |
| 5 RUC M5 | 6+6 FORI- <i>HOLES</i> M5 | 1/8" | 10 |
| 6 RUC 1/8" | 2+2 FORI- <i>HOLES</i> 1/8" | 1/4" | 10 |
| 7 RUC 1/8" | 3+3 FORI- <i>HOLES</i> 1/8" | 1/4" | 10 |
| 8 RUC 1/8" | 4+4 FORI- <i>HOLES</i> 1/8" | 1/4" | 10 |
| 9 RUC 1/8" | 5+5 FORI- <i>HOLES</i> 1/8" | 1/4" | 10 |
| 10 RUC 1/8" | 6+6 FORI- <i>HOLES</i> 1/8" | 1/4" | 10 |
| 11 RUC 1/4" | 2+2 FORI- <i>HOLES</i> 1/4" | 3/8" | 10 |
| 12 RUC 1/4" | 3+3 FORI- <i>HOLES</i> 1/4" | 3/8" | 10 |
| 13 RUC 1/4" | 4+4 FORI- <i>HOLES</i> 1/4" | 3/8" | 10 |
| 14 RUC 1/4" | 5+5 FORI- <i>HOLES</i> 1/4" | 3/8" | 10 |
| 15 RUC 1/4" | 6+6 FORI- <i>HOLES</i> 1/4" | 3/8" | 10 |
| 16 RUC 1/4" | 2+2 FORI- <i>HOLES</i> 1/4" | 1/2" | 10 |
| 17 RUC 1/4" | 3+3 FORI- <i>HOLES</i> 1/4" | 1/2" | 10 |
| 18 RUC 1/4" | 4+4 FORI- <i>HOLES</i> 1/4" | 1/2" | 10 |
| 19 RUC 1/4" | 5+5 FORI- <i>HOLES</i> 1/4" | 1/2" | 10 |
| 20 RUC 1/4" | 6+6 FORI- <i>HOLES</i> 1/4" | 1/2" | 10 |
| 21 RUC 3/8" | 2+2 FORI- <i>HOLES</i> 3/8" | 1/2" | 10 |
| 22 RUC 3/8" | 3+3 FORI- <i>HOLES</i> 3/8" | 1/2" | 10 |
| 23 RUC 3/8" | 4+4 FORI- <i>HOLES</i> 3/8" | 1/2" | 10 |
| 24 RUC 3/8" | 5+5 FORI- <i>HOLES</i> 3/8" | 1/2" | 10 |
| 25 RUC 3/8" | 6+6 FORI- <i>HOLES</i> 3/8" | 1/2" | 10 |
| 26 RUC 1/2" | 2+2 FORI- <i>HOLES</i> 1/2" | 1/2" | 10 |
| 27 RUC 1/2" | 3+3 FORI- <i>HOLES</i> 1/2" | 1/2" | 10 |
| 28 RUC 1/2" | 4+4 FORI- <i>HOLES</i> 1/2" | 1/2" | 10 |
| 29 RUC 1/2" | 5+5 FORI- <i>HOLES</i> 1/2" | 1/2" | 10 |
| 30 RUC 1/2" | 6+6 FORI- <i>HOLES</i> 1/2" | 1/2" | 10 |

FILTRI SINTERIZZATI

FILTRI IN BRONZO



| | |
|---|--|
| COMPOSIZIONE | 89% RAME - 11% STAGNO |
| DENSITÀ | 4,5 ÷ 5,5 |
| POROSITÀ | 30 ÷ 50% |
| COEFFICIENTE DI DILATAZIONE LINEARE A 20 °C | 18 X 10 ⁶ |
| RESISTENZA ALLA TRAZIONE A 20 °C | 3 ÷ 6 Kg/mm ² |
| ALLUNGAMENTO | 2 ÷ 3% |
| FILTRAZIONE (SOGLIA DI ARRESTO) | 5 μ ÷ 100 μ |
| TEMPERATURA MASSIMA DI IMPIEGO | 200 °C in aria - 450 °C in atm riducente |

FILTRI IN ACCIAIO INOX



| | |
|---|--|
| COMPOSIZIONE | AISI 316 L |
| DENSITÀ | 4,5 ÷ 5,5 |
| POROSITÀ | 30 ÷ 40% |
| COEFFICIENTE DI DILATAZIONE LINEARE A 20 °C | 17 X 10 ⁶ |
| RESISTENZA ALLA TRAZIONE A 20 °C | 4 ÷ 10 Kg/mm ² |
| ALLUNGAMENTO | 2 ÷ 3% |
| FILTRAZIONE (SOGLIA DI ARRESTO) | 1 μ ÷ 50 μ |
| TEMPERATURA MASSIMA DI IMPIEGO | 450 °C in aria - 850 °C in atm riducente |

FILTRI IN FILO



| | |
|---------------------------------|--|
| COMPOSIZIONE | AISI 304/316 - ALLUMINIO |
| DENSITÀ | 2 ÷ 5 |
| DIAMETRO FILO | 0,12 ÷ 0,30 |
| POROSITÀ | 30 ÷ 80% |
| FILTRAZIONE (SOGLIA DI ARRESTO) | 10 μ ÷ 150 μ |
| TEMPERATURA MASSIMA DI IMPIEGO | Dipende dal materiale utilizzato per la costruzione del filo |

FILTRI IN PE-HD



| | |
|---|---|
| COMPOSIZIONE | POLIETILENE HD |
| DENSITÀ | 0,5 ÷ 1 |
| POROSITÀ | 20 ÷ 60% |
| COEFFICIENTE DI DILATAZIONE LINEARE A 20 °C | 20 X 10 ⁶ |
| FILTRAZIONE (SOGLIA DI ARRESTO) | 1 μ ÷ 50 μ |
| TEMPERATURA MASSIMA DI IMPIEGO | 80 °C (Continuo) - 100 °C (Intermittente) |

BRONZE FILTERS



| | |
|--|---|
| MATERIAL | 89% COPPER - 11% TIN |
| DENSITY | 4,5 ÷ 5,5 |
| POROSITY | 30 ÷ 50% |
| LINEAR EXPANSION COEFFICIENT AT 20 ° C | 18 X 10 ⁶ |
| RESISTANCE TO TRACTION AT 20 ° C | 3 ÷ 6 Kg/mm ² |
| ELONGATION | 2 ÷ 3% |
| FILTRATION (STOP THRESHOLD) | 5 μ ÷ 100 μ |
| MAXIMUM TEMPERATURE OF USE | 200°C in air - 450°C in reducing atmosphere |

STAINLESS STEEL FILTERS



| | |
|--|---|
| MATERIAL | AISI 316 L |
| DENSITY | 4,5 ÷ 5,5 |
| POROSITY | 30 ÷ 40% |
| LINEAR EXPANSION COEFFICIENT AT 20 ° C | 17 X 10 ⁶ |
| RESISTANCE TO TRACTION AT 20 ° C | 4 ÷ 10 Kg/mm ² |
| ELONGATION | 2 ÷ 3% |
| FILTRATION (STOP THRESHOLD) | 1 μ ÷ 50 μ |
| MAXIMUM TEMPERATURE OF USE | 450°C in air - 850°C in reducing atmosphere |

WIRE FILTERS



| | |
|-----------------------------|--|
| MATERIAL | AISI 304/316 - ALUMINIUM |
| DENSITY | 2 ÷ 5 |
| WIRE DIAMETER | 0,12 ÷ 0,30 |
| POROSITY | 30 ÷ 80% |
| FILTRATION (STOP THRESHOLD) | 10 μ ÷ 150 μ |
| MAXIMUM TEMPERATURE OF USE | It depends on the material used for the construction of the wire |

HD-PE FILTERS



| | |
|--------------------------------------|--|
| MATERIAL | HD POLYETHYLENE |
| DENSITY | 0,5 ÷ 1 |
| POROSITY | 20 ÷ 60% |
| LINEAR EXPANSION COEFFICIENT AT 20°C | 20 X 10 ⁶ |
| FILTRATION (STOP THRESHOLD) | 1 μ ÷ 50 μ |
| MAXIMUM TEMPERATURE OF USE | 80°C (Continuous) - 100°C (Intermittent) |

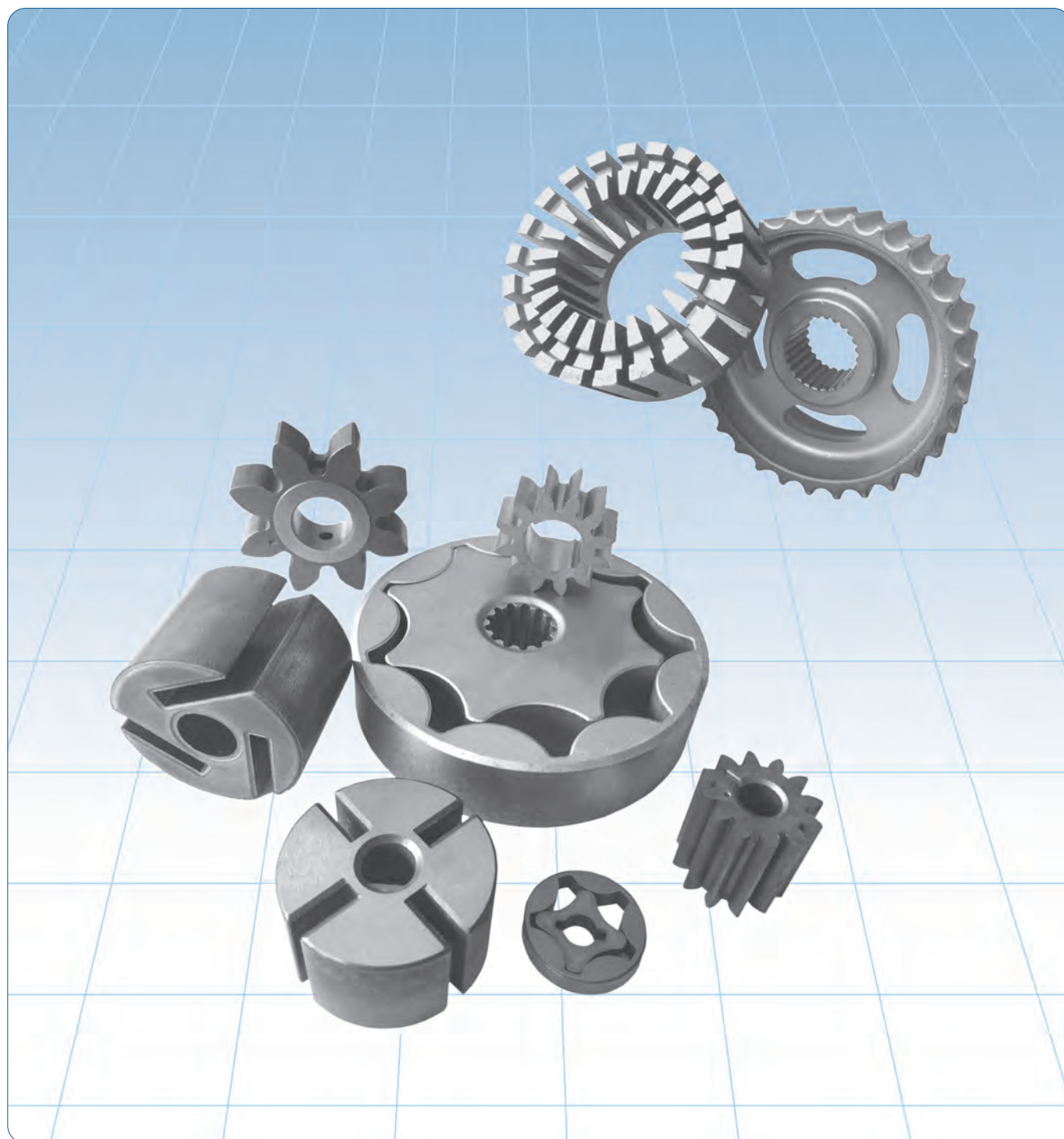

Per maggiori chiarimenti e specifiche consultare il relativo Fascicolo Tecnico.
For further clarifications and specifications, consult the relevant Technical File.

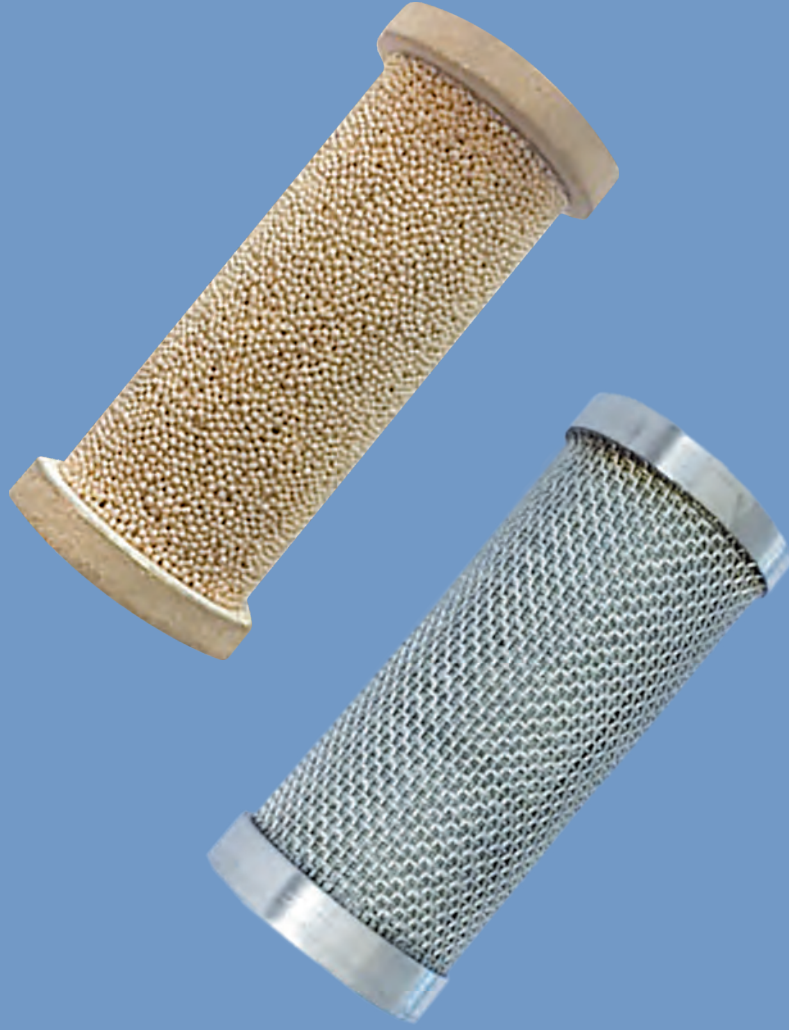



GLUE FILTERS

FILTRI PER COLLA - *GLUE FILTERS*

| H 100 | |
|---|--|
| COD | 🛒 |
| FILBRH100-50 Filtro bronzo H100 | 5 |
| <i>FILBRH100-50</i> <i>Bronze filter H100</i> | |
| Forato nella parte inferiore Parte superiore: filetto M5 | |
| <i>Hole at the bottom</i> <i>Thread in the upper part M5</i> | |
|  |  OR in NBR - Viton OR in NBR - Viton |

| H 50 | |
|--|--|
| COD | 🛒 |
| FILBRH50-50 Filtro bronzo H50 | 5 |
| <i>FILBRH50-50</i> <i>Bronze filter H50</i> | |
| Forato nella parte inferiore Parte superiore: filetto M5 | |
| <i>Hole at the bottom</i> <i>Thread in the upper part M5</i> | |
|  | A richiesta H 45 <i>On request H 45</i> |
|  OR in NBR - Viton OR in NBR - Viton | |

| H 30 | |
|---|--|
| COD | 🛒 |
| FILBRH30-50 Filtro bronzo H30 | 5 |
| <i>FILBRH30-50</i> <i>Bronze filter H30</i> | |
| Forato nella parte inferiore Parte superiore: filetto M5 | |
| <i>Hole at the bottom</i> <i>Thread in the upper part M5</i> | |
|  |  OR in NBR - Viton OR in NBR - Viton |

| H 100-X | |
|--|------------|
| COD | 🛒 |
| FILRXH100-50 Filtro inox H100 | 5 |
| <i>FILRXH100-50</i> <i>Stainless filter H100</i> | |
| Forato nella parte inferiore Parte superiore: filetto M5 | |
| <i>Hole at the bottom</i> <i>Thread in the upper part M5</i> | |
|  | AISI 316 L |
|  OR in Viton OR in Viton | |

| H 50-X | |
|--|------------|
| COD | 🛒 |
| FILRXH50-50 Filtro inox H50 | 5 |
| <i>FILRXH50-50</i> <i>Stainless filter H50</i> | |
| Forato nella parte inferiore Parte superiore: filetto M5 | |
| <i>Hole at the bottom</i> <i>Thread in the upper part M5</i> | |
|  | AISI 316 L |
|  OR in Viton OR in Viton | |

| H 30-X | |
|--|------------|
| COD | 🛒 |
| FILRXH30-50 Filtro inox H30 | 5 |
| <i>FILRXH30-50</i> <i>Stainless filter H30</i> | |
| Forato nella parte inferiore Parte superiore: filetto M5 | |
| <i>Hole at the bottom</i> <i>Thread in the upper part M5</i> | |
|  | AISI 316 L |
|  OR in Viton OR in Viton | |

| H 11 | |
|---|----|
| COD | 🛒 |
| FILBRH11-50 Filtro bronzo H11 | 25 |
| <i>FILBRH11-50</i> <i>Bronze filter H11</i> | |
| Forato nella parte inferiore | |
| <i>Hole at the bottom</i> | |
|  | |

| H 25 | |
|--|----|
| COD | 🛒 |
| FILBRH25-50 Filtro bronzo H25 | 25 |
| <i>FILBRH25-50</i> <i>Bronze filter H25</i> | |
| Forato nella parte inferiore | |
| <i>Hole at the bottom</i> | |
|  | |

STANDARD 50 μ - A RICHIESTA 80 μ - *STANDARD 50 μ - ON REQUEST 80 μ*



Il filtro inserito nella pistola applicatrice garantisce un'erogazione costante e precisa dell'adesivo nel tempo, in quanto tutte le impurità vengono trattenute all'interno di esso. Sono disponibili filtri in inox o bronzo sinterizzato, interni o esterni alla pistola. Il filtro può essere esterno al corpo pistola oppure integrato. Impedisce che ostruzioni raggiungano l'ugello di erogazione. La pulizia o la sua sostituzione avviene tramite semplici operazioni, senza dovere disconnettere il tubo della pistola.

The filter in the applicator gun ensures constant and precise distribution of the adhesive over time, as it soaks up all impurities. Filters are available in Stainless steel or sintered bronze, either inside or outside the gun. The filter can be external to the gun body or integrated. It prevents obstructions in the spray nozzle. The filter can be easily cleaned or replaced without disconnecting the gun tube.

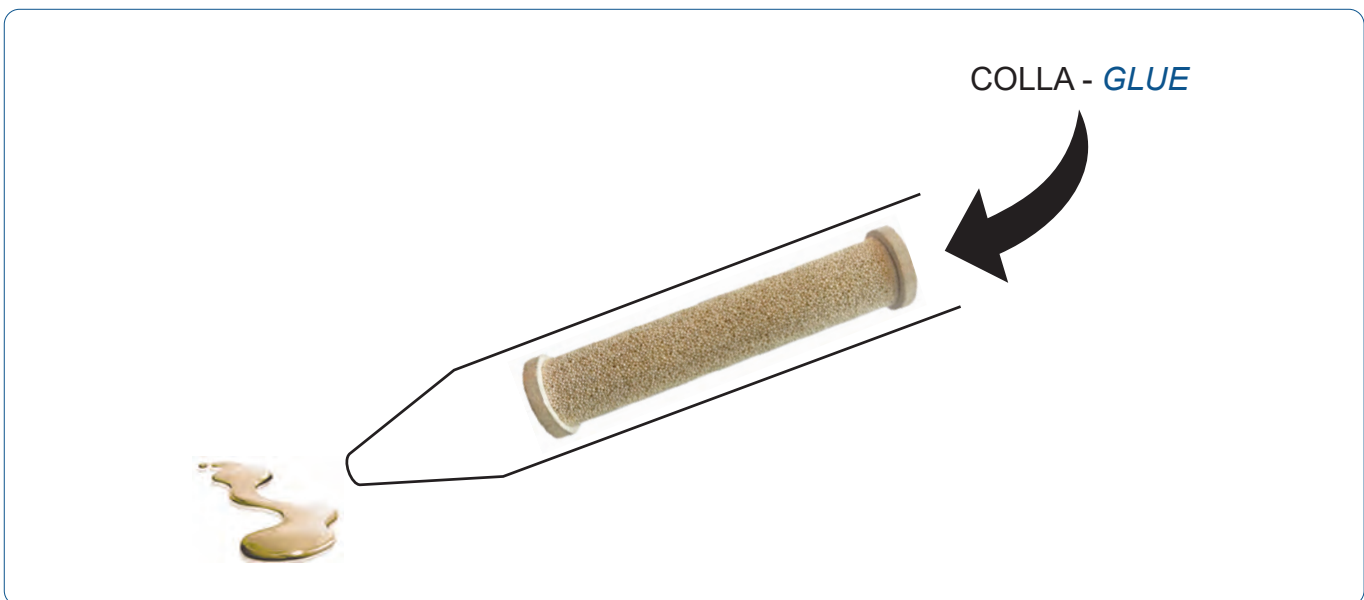

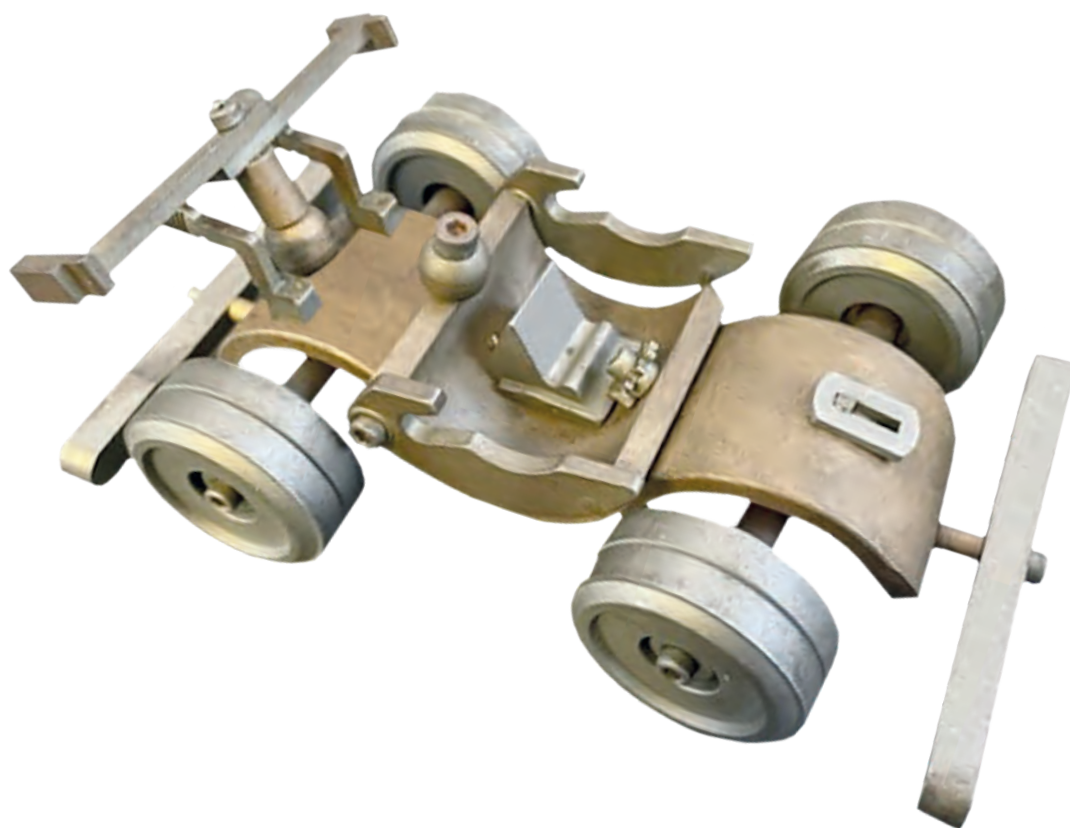

1978 - Modello realizzato con particolari sinterizzati SAS
1978 - Model made with SAS sintered parts



TUBES

TUBI E SPIRALI - TUBES AND SPIRALS

SPIRALI CALIBRATE POLIURETANO 98 ShA - CALIBRATED POLYURETHANE 98 ShA SPIRAL TUBES



Colore standard:



Azzurro (LB)

Con codolo e senza raccordi
Altri colori e dimensioni: a richiesta
Temperatura di utilizzo: -30 °C ÷ + 60°C

Standard color:



Light blue (LB)

With shank and without fittings
Other colors and sizes: on request
Working pressure: -30 °C ÷ + 60°C

| DIMENSIONI SIZE | | COD | COLORE STANDARD STANDARD COLOR | LUNGHEZZA ESTESA (m) EXTENDED LENGHT (m) | Ø ESTERNO SPIRA (mm) Ø EXT SPIRE (mm) | PRESSIONE DI UTILIZZO 23 °C WORKING PRESSURE 23 °C (Bar) | PRESSIONE DI SCOPPIO 23 °C BURSTING PRESSURE 23 °C (Bar) | 🛒 |
|----------------------|----------------------|--------------|---|---|--|--|--|---|
| Ø INT Ø INT mm | Ø EST Ø EXT mm | | | | | | | |
| 5 | 8 | SPU 58 - 2 | LB | 2 | 42 | 13 | 52 | 1 |
| 5 | 8 | SPU 58 - 4 | LB | 4 | 42 | 13 | 52 | 1 |
| 5 | 8 | SPU 58 - 6 | LB | 6 | 42 | 13 | 52 | 1 |
| 5 | 8 | SPU 58 - 8 | LB | 8 | 42 | 13 | 52 | 1 |
| 6,5 | 10 | SPU 6510 - 2 | LB | 2 | 52 | 10 | 40 | 1 |
| 6,5 | 10 | SPU 6510 - 4 | LB | 4 | 52 | 10 | 40 | 1 |
| 6,5 | 10 | SPU 6510 - 6 | LB | 6 | 52 | 10 | 40 | 1 |
| 6,5 | 10 | SPU 6510 - 8 | LB | 8 | 52 | 10 | 40 | 1 |
| 8 | 12 | SPU 812 - 2 | LB | 2 | 65 | 9 | 36 | 1 |
| 8 | 12 | SPU 812 - 4 | LB | 4 | 65 | 9 | 36 | 1 |
| 8 | 12 | SPU 812 - 6 | LB | 6 | 65 | 9 | 36 | 1 |
| 8 | 12 | SPU 812 - 8 | LB | 8 | 65 | 9 | 36 | 1 |

TUBO POLIURETANO 98 ShA - CALIBRATED POLYURETHANE 98 ShA TUBES



Colori standard:



Azzurro (LB) Rosso (R) Nero (B)

Altri colori e dimensioni: a richiesta
Temperatura di utilizzo: -30 °C ÷ + 60°C

Standard colors:



Light Blue (LB) Red (R) Black (B)

Other colors and sizes: on request
Working pressure: -30 °C ÷ + 60°C

| DIMENSIONI SIZE | | COD | COLORI STANDARD STANDARD COLORS | BOBINA (m) COIL LENGHT(m) | PRESSIONE DI UTILIZZO 23 °C WORKING PRESSURE 23 °C (Bar) | PRESSIONE DI SCOPPIO 23 °C BURSTING PRESSURE 23 °C (Bar) | RAGGIO DI CURVATURA 23 °C (mm) BENDING RAY 23 °C (mm) | 🛒 |
|----------------------|----------------------|-----------|--|------------------------------|--|--|---|---|
| Ø INT Ø INT mm | Ø EST Ø EXT mm | | | | | | | |
| 2 | 4 | PU - 24 | LB-R-B | 100 | 15 | 60 | 17 | 1 |
| 2,5 | 4 | PU - 254 | LB-R-B | 100 | 10 | 40 | 15 | 1 |
| 3 | 5 | PU - 35 | LB-R-B | 100 | 12 | 50 | 16 | 1 |
| 4 | 6 | PU - 46 | LB-R-B | 100 | 10 | 40 | 18 | 1 |
| 5 | 8 | PU - 58 | LB-R-B | 100 | 13 | 52 | 25 | 1 |
| 5,5 | 8 | PU - 558 | LB-R-B | 100 | 10 | 40 | 30 | 1 |
| 6 | 8 | PU - 68 | LB-R-B | 100 | 7 | 28 | 35 | 1 |
| 7,5 | 10 | PU - 7510 | LB-R-B | 100 | 10 | 40 | 30 | 1 |
| 8 | 10 | PU - 810 | LB-R-B | 100 | 6 | 22 | 45 | 1 |
| 8 | 12 | PU - 812 | LB-R-B | 100 | 9 | 36 | 50 | 1 |

TUBO CALIBRATO POLIAMMIDE PA 11 (RILSAN) - CALIBRATED POLYAMIDE TUBES (RILSAN PA 11)



Colori standard:



Azzurro (LB) Neutro

Standard colors:



Light blue (LB) Neutral

Altri colori e dimensioni: a richiesta
Temperatura di utilizzo: - 40 °C ++ 80 °C

Other colors and sizes: on request
Working pressure: - 40 °C ++ 80 °C

| DIMENSIONI SIZE | | COD | COLORI STANDARD STANDARD COLORS | BOBINA (m) COIL LENGHT (m) | PRESSIONE DI UTILIZZO 23 °C WORKING PRESSURE 23 °C (Bar) | PRESSIONE DI SCOPPIO 23 °C BURSTING PRESSURE 23 °C (Bar) | RAGGIO DI CURVATURA 23 °C (mm) BENDING RAY 23 °C (mm) | 🛒 |
|----------------------|----------------------|--------|--|-------------------------------------|--|--|---|---|
| Ø INT Ø INT mm | Ø EST Ø EXT mm | | | | | | | |
| 2 | 4 | PA 24 | LB - Neutro - Neutral | 200 | 44 | 130 | 15 | 1 |
| 2,5 | 4 | PA 254 | LB - Neutro - Neutral | 200 | 36 | 108 | 20 | 1 |
| 4 | 6 | PA 46 | LB - Neutro - Neutral | 200 | 27 | 81 | 40 | 1 |
| 6 | 8 | PA 68 | LB - Neutro - Neutral | 100 | 20 | 60 | 50 | 1 |
| 8 | 10 | PA 810 | LB - Neutro - Neutral | 100 | 15 | 45 | 60 | 1 |
| 9 | 12 | PA 912 | LB - Neutro - Neutral | 100 | 20 | 60 | 80 | 1 |

TUBO TEFLON (PTFE) - TEFLON TUBE (PTFE)



Colore standard:



Neutro

Standard color:



Neutral

Altri colori e dimensioni: a richiesta
Temperatura di utilizzo: - 73 °C ++ 200 °C

Other colors and sizes: on request
Working pressure: - 73 °C ++ 200 °C

| DIMENSIONI SIZE | | COD | COLORE STANDARD STANDARD COLOR | BOBINA (m) COIL LENGHT (m) | PRESSIONE DI UTILIZZO 23 °C WORKING PRESSURE 23 °C (Bar) | PRESSIONE DI SCOPPIO 23 °C BURSTING PRESSURE 23 °C (Bar) | RAGGIO DI CURVATURA 23 °C (mm) BENDING RAY 23 °C (mm) | 🛒 |
|----------------------|----------------------|-------------|---|-------------------------------------|--|--|---|---|
| Ø INT Ø INT mm | Ø EST Ø EXT mm | | | | | | | |
| 2 | 4 | PTFE - 24 | Neutro - Neutral | 100 | 33 | 100 | 20 | 1 |
| 4 | 6 | PTFE - 46 | Neutro - Neutral | 100 | 18 | 54 | 30 | 1 |
| 6 | 8 | PTFE - 68 | Neutro - Neutral | 100 | 14 | 42 | 40 | 1 |
| 8 | 10 | PTFE - 810 | Neutro - Neutral | 50 | 12 | 36 | 50 | 1 |
| 10 | 12 | PTFE - 1012 | Neutro - Neutral | 50 | 10 | 30 | 85 | 1 |
| 12 | 14 | PTFE - 1214 | Neutro - Neutral | 50 | 6 | 20 | 100 | 1 |

PT

COD
PT 🛒 5



Pinza taglia tubo - Logo su richiesta
Pipe cutter - Logo on request

PT-M

COD
PT-M 🛒 5



Metro estensibile
Extendable meter

Pinza taglia tubo - Logo su richiesta
Pipe cutter - Logo on request



Per maggiori chiarimenti e specifiche consultare il relativo Fascicolo Tecnico.
For further clarifications and specifications, consult the relevant Technical File.



CARATTERISTICHE

Produzione italiana
Lama temprata a lunga durata
Personalizzazione con logo in rilievo o stampato (tampografia)
Disponibili in diversi colori

FEATURES

*Italian Production
Long life hardened blade
Customization with embossed or printed logo
Available in different colors*

PISTOLE PER ARIA COMPRESSA - COMPRESSED AIR GUNS



| | |
|---|-----------------------------------|
| Erogazione <i>Outlet</i> | Progressiva <i>Progressive</i> |
| Pressione max di esercizio <i>Maximum working pressure</i> | 10 Bar |
| Temperatura d'uso <i>Use temperature</i> | -25 °C + +85 °C |
| Peso <i>Weight</i> | 98 gr. |
| Attacco femmina <i>Cylindrical connection female</i> | 1/4 Gas |
| Emissione sonora <i>Noise level</i> | 78 dB |

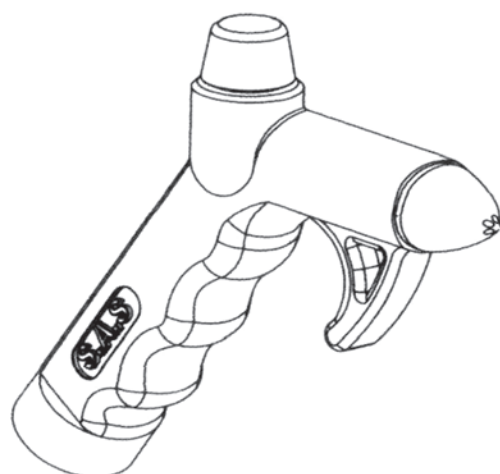

| | |
|---|-----------------------------------|
| Erogazione <i>Outlet</i> | Progressiva <i>Progressive</i> |
| Pressione max di esercizio <i>Maximum working pressure</i> | 10 Bar |
| Temperatura d'uso <i>Use temperature</i> | -25 °C + +85 °C |
| Peso <i>Weight</i> | 62 gr. |
| Attacco femmina <i>Cylindrical connection female</i> | 1/4 Gas |
| Emissione sonora <i>Noise level</i> | 80 dB |

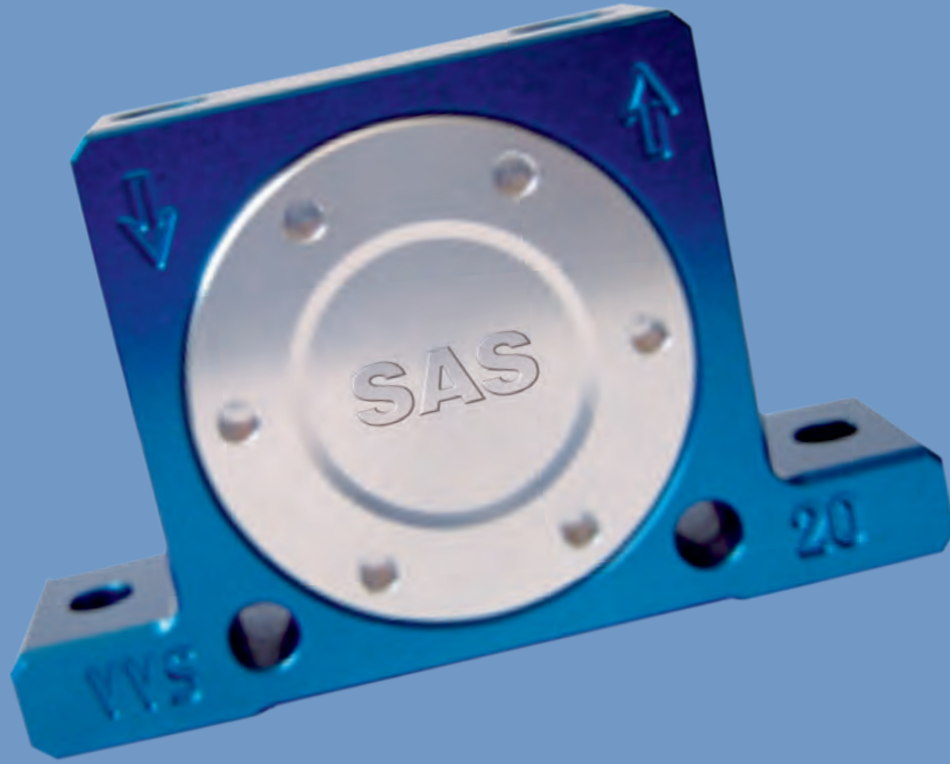

VIBRATORS

VIBRATORI PNEUMATICI - PNEUMATIC VIBRATORS

VS-SFERA - VS-BALL



VIBRAZIONI AL MINUTO - VIBRATIONS PER MINUTE

| COD | 2 BAR | 4 BAR | 6 BAR | 🛒 |
|-------|-------|-------|-------|---|
| VS 08 | 20520 | 29100 | 34260 | 1 |
| VS 10 | 19920 | 27300 | 32760 | 1 |
| VS 13 | 11700 | 17520 | 20760 | 1 |
| VS 16 | 9300 | 14160 | 17700 | 1 |
| VS 20 | 7680 | 11100 | 13020 | 1 |
| VS 25 | 6900 | 9900 | 12000 | 1 |
| VS 30 | 5820 | 8100 | 9900 | 1 |
| VS 36 | 5520 | 7920 | 9600 | 1 |

A RICHIESTA DISPONIBILE ANCHE DI IMPORTAZIONE - AVAILABLE ON IMPORTATION ON REQUEST

VT-TURBINA - VT TURBINE

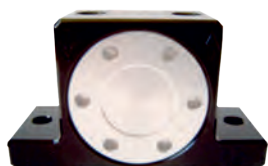

VIBRAZIONI AL MINUTO - VIBRATIONS PER MINUTE

| COD | 2 BAR | 4 BAR | 6 BAR | 🛒 |
|-------|-------|-------|-------|---|
| VT 08 | 31020 | 39780 | 45120 | 1 |
| VT 10 | 23280 | 29700 | 33900 | 1 |
| VT 12 | 21000 | 27420 | 30600 | 1 |
| VT 13 | 20152 | 25126 | 28425 | 1 |
| VT 16 | 15280 | 18840 | 21300 | 1 |
| VT 19 | 14250 | 17659 | 19846 | 1 |
| VT 20 | 14880 | 19680 | 22560 | 1 |
| VT 25 | 11400 | 14820 | 16860 | 1 |
| VT 29 | 10980 | 14100 | 16200 | 1 |
| VT 30 | 10709 | 13603 | 17162 | 1 |
| VT 36 | 8120 | 10200 | 12860 | 1 |
| VT 40 | 7573 | 9561 | 11982 | 1 |

VR-RULLO - VR-ROLLER



VIBRAZIONI AL MINUTO - VIBRATIONS PER MINUTE

| COD | 2 BAR | 4 BAR | 6 BAR | 🛒 |
|--------|-------|-------|-------|---|
| VR 040 | 25440 | 35460 | 42060 | 1 |
| VR 060 | 23220 | 31020 | 34380 | 1 |
| VR 080 | 12360 | 21120 | 23640 | 1 |
| VR 100 | 9800 | 14580 | 16200 | 1 |

VP-PISTONE - VP- PISTON



VIBRAZIONI AL MINUTO - VIBRATIONS PER MINUTE

| COD | 2 BAR | 4 BAR | 6 BAR | 🛒 |
|-------|-------|-------|-------|---|
| VP 15 | 3840 | 5100 | 6000 | 1 |
| VP 22 | 2180 | 2820 | 3300 | 1 |
| VP 30 | 2100 | 2640 | 3000 | 1 |
| VP 45 | 1740 | 2040 | 2400 | 1 |

VPB - PISTONE A BATTUTA
VPB - IMPACT VIBRATORS



VIBRAZIONI AL MINUTO - VIBRATIONS PER MINUTE

| COD | 2 BAR | 4 BAR | 6 BAR | 🛒 |
|--------|-------|-------|-------|---|
| VPB 25 | 2760 | 3840 | 4920 | 1 |
| VPB 40 | 1560 | 2280 | 2820 | 1 |
| VPB 60 | 1260 | 1680 | 1980 | 1 |

VEC - MINI VIBRATORE ELETTRICO
VEC - MINI ELECTRIC VIBRATOR

| COD | VIBRAZIONI AL MINUTO (rpm) VIBRATIONS PER MINUTE (rpm) |  |
|-----|---|---|
| VEC | 8000 ÷ 24000 | 1 |

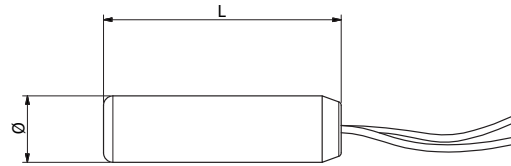

CARATTERISTICHE

| | |
|--|-----------------------|
| Dimensioni: | Ø=7 x 25 (L) mm |
| Tensione di alimentazione (corrente continua): | 1,5 ÷ 3 VCC |
| Vibrazioni al minuto: | 8000 ÷ 24000 rpm |
| Potenza: | 0,01 ÷ 0,06 W |
| Coppia: | 0,3 g.cm ÷ 3g.cm (NM) |

Utilizzando acciaio inossidabile **AISI 316** (ad alta resistenza) la qualità del sistema (cuscinetto e durata del motoriduttore) è ottimizzata, rendendo il prodotto estremamente affidabile. Questo vibratore senza albero è particolarmente adatto per indicare una variazione delle condizioni di utilizzo. Tutte le parti mobili all'interno dell'alloggiamento sono protette da vernice epossidica per evitare il contatto con liquidi.

FEATURES

| | |
|---|----------------------|
| <i>Size:</i> | Ø=7 x 25 (L) mm |
| <i>Supply voltage (direct current):</i> | 1.5÷3 VCC |
| <i>Vibrations per minute:</i> | 8000 ÷ 24000 rpm |
| <i>Power:</i> | 0.01 ÷ 0.06W |
| <i>Torque:</i> | 0.3g.cm ÷ 3g.cm (NM) |

*By using **AISI 316** stainless steel (high resistance) the quality of the system (bearing and life of the gearmotor) is optimised, making the product extremely reliable. This shaftless vibrator is particularly suitable for indicating a change in the conditions of use. All moving parts inside the housing are protected by epoxy paint to avoid contact with liquids.*

VEP - MINI VIBRATORE ELETTRICO
VEP - MINI ELECTRIC VIBRATOR

| COD | VIBRAZIONI AL MINUTO (rpm) VIBRATIONS PER MINUTE (rpm) |  |
|-----|---|---|
| VEP | 10000 ÷ 12000 | 1 |

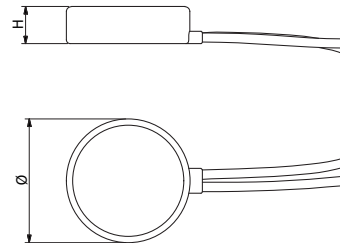

CARATTERISTICHE

| | |
|--|-------------------|
| Dimensioni: | Ø=10 x 3 (H) mm |
| Tensione di alimentazione (corrente continua): | 3 VCC |
| Vibrazioni al minuto: | 10000 ÷ 12000 rpm |
| Temperatura di utilizzo: | -20 ÷ +60 C° |

Micromotore a vibrazione autoadesivo per cellulare, cercapersone. Ampiamente utilizzato in telefoni cellulari, giocattoli, prodotti sanitari, oggetti d'arte, prodotti elettronici, apparecchiature mediche, tablet, dispositivi indossabili e orologi intelligenti che richiedono feedback di vibrazione per l'avviso anziché pulsanti fisici. Utilizzato anche in scanner RFID, giocattoli, prodotti sanitari, oggetti d'arte, prodotti elettronici, apparecchiature mediche, strumenti industriali o interfacce utente di apparecchiature ecc..

FEATURES

| | |
|---|-------------------|
| <i>Size:</i> | Ø=10 x 3 (L) mm |
| <i>Supply voltage (direct current):</i> | 3 VCC |
| <i>Vibrations per minute:</i> | 10000 ÷ 12000 rpm |
| <i>Operating temperature:</i> | -20 ÷ +60 C° |

Self-adhesive vibration micromotor for mobile phone, pager. Widely used in mobile phones, toys, health care products, art objects, electronic products, medical equipment, tablets, wearable devices and smart watches which require vibration feedback for alert instead of physical buttons. Also used in RFID scanners, toys, health products, art objects, electronic products, medical equipment, industrial instruments or equipment user interfaces etc.



Materiale: **AISI 316 L**
Material: **AISI 316 L**

Per maggiori chiarimenti e specifiche consultare il relativo Fascicolo Tecnico.
For further clarifications and specifications, consult the relevant Technical File.



ROTARY JOINTS

GRS - GIUNTO CON INNESTO RAPIDO DI SICUREZZA
GRS - ROTATING UNIONS WITH QUICK SAFETY COUPLING



| COD | DIMENSIONI - SIZES | 🛒 |
|--------|--------------------|---|
| GRS 25 | 1/4" | 1 |
| GRS 37 | 3/8" | 1 |
| GRS 50 | 1/2" | 1 |

GUP - GIUNTO UNIVERSALE PNEUMATICO - 10 BAR - 300 RPM
GUP - HIGH SPEED UNIVERSAL PNEUMATIC ROTATING UNIONS 10 BAR - 3000 RPM



| COD | DIMENSIONI - SIZES | 🛒 |
|--------|--------------------|---|
| GUP 12 | 1/8" | 1 |
| GUP 25 | 1/4" | 1 |
| GUP 37 | 3/8" | 1 |
| GUP 50 | 1/2" | 1 |

GPI - GIUNTO PNEUMO IDRAULICO SERVIZIO PESANTE - 350 BAR - 120 RPM
GPI - HIGH PRESSURE PNEUMO-HYDRAULIC ROTATING UNIONS - 350 BAR - 120 RPM



| COD | DIMENSIONI - SIZES | 🛒 |
|--------|--------------------|---|
| GPI 25 | 1/4" | 1 |
| GPI 37 | 3/8" | 1 |
| GPI 50 | 1/2" | 1 |

GRV - GIUNTO ROTANTE PER VAPORE - 35 BAR - 400 RPM
GRV - ROTATING UNIONS FOR STEAM - 35 BAR - 400 RPM



| COD | DIMENSIONI - SIZES | 🛒 |
|--------|--------------------|---|
| GRV 25 | 1/4" | 1 |
| GRV 37 | 3/8" | 1 |
| GRV 50 | 1/2" | 1 |

GPAV - GIUNTO PNEUMATICO ALTA VELOCITÀ - 70 BAR - 5000 RPM
GPAV - HIGH SPEED PNEUMATIC ROTATING UNIONS - 70 BAR - 5000 RPM



| COD | DIMENSIONI - SIZES | 🛒 |
|---------|--------------------|---|
| GPAV 25 | 1/4" | 1 |
| GPAV 37 | 3/8" | 1 |
| GPAV 50 | 1/2" | 1 |

SGA / SGR - SNODI GIREVOLI
SGA / SGR - ROTATING JOINTS



SGA - SGA TYPE



SGR - SGR TYPE

| COD | DIMENSIONI - SIZES | 🛒 |
|--------|--------------------|---|
| SGA 25 | 1/4" | 1 |
| SGA 37 | 3/8" | 1 |
| SGA 50 | 1/2" | 1 |
| SGA 75 | 3/4" | 1 |
| SGR 25 | 1/4" | 1 |
| SGR 37 | 3/8" | 1 |
| SGR 50 | 1/2" | 1 |
| SGR 75 | 3/4" | 1 |

GRF - GIUNTO ROTANTE FEMMINA AD UNA VIA
GRF - ONE WAY FEMALE ROTARY JOINT

| COD | ENTRATA - INLET | USCITA - OUTLET | 🛒 |
|-------------|-----------------|-----------------|---|
| GRF-1-1/8" | 1-G 1/8" | 1-G 1/8" | 1 |
| GRF-1-1/4" | 1-G 1/4" | 1-G 1/4" | 1 |
| GRF-1-3/8" | 1-G 3/8" | 1-G 3/8" | 1 |
| GRF-1-1/2" | 1-G 1/2" | 1-G 1/2" | 1 |
| GRF-1-3/4" | 1-G 3/4" | 1-G 3/4" | 1 |
| GRF-1-1" | 1-G 1" | 1-G 1" | 1 |
| GRF-1-1"1/4 | 1-G 1"-1/4 | 1-G 1"-1/4 | 1 |
| GRF-1-1"1/2 | 1-G 1"-1/2 | 1-G 1"-1/2 | 1 |

GRM - GIUNTO ROTANTE MASCHIO AD UNA VIA
GRM - ONE WAY MALE ROTARY JOINT

| COD | ENTRATA - INLET | USCITA - OUTLET | 🛒 |
|-------------|-----------------|-----------------|---|
| GRM-1-1/8" | 1-G 1/8" | 1-G 1/8" | 1 |
| GRM-1-1/4" | 1-G 1/4" | 1-G 1/4" | 1 |
| GRM-1-3/8" | 1-G 3/8" | 1-G 3/8" | 1 |
| GRM-1-1/2" | 1-G 1/2" | 1-G 1/2" | 1 |
| GRM-1-3/4" | 1-G 3/4" | 1-G 3/4" | 1 |
| GRM-1-1" | 1-G 1" | 1-G 1" | 1 |
| GRM-1-1"1/4 | 1-G 1"-1/4 | 1-G 1"-1/4 | 1 |
| GRM-1-1"1/2 | 1-G 1"-1/2 | 1-G 1"-1/2 | 1 |

GRF - GIUNTO ROTANTE FEMMINA A QUATTRO VIE
GRF - FOUR WAY FEMALE ROTARY JOINT

| COD | ENTRATA - INLET | USCITA - OUTLET | 🛒 |
|------------|-----------------|-----------------|---|
| GRF-4-1/4" | 1-G 3/8" | 3-G 1/4" | 1 |
| GRF-4-1/2" | 1-G 3/4" | 3-G 1/2" | 1 |

GRM - GIUNTO ROTANTE MASCHIO A QUATTRO VIE
GRM - FOUR WAY MALE ROTARY JOINT

| COD | ENTRATA - INLET | USCITA - OUTLET | 🛒 |
|------------|-----------------|-----------------|---|
| GRM-4-1/8" | 1-G 3/8" | 3-G 1/8" | 1 |
| GRM-4-1/4" | 1-G 3/8" | 3-G 1/4" | 1 |
| GRM-4-1/2" | 1-G 3/4" | 3-G 1/2" | 1 |

GRF - GIUNTO ROTANTE FEMMINA A SEI VIE
GRF - SIX WAY FEMALE ROTARY JOINT



| COD | ENTRATA - INLET | USCITA - OUTLET | 🛒 |
|------------|-----------------|-----------------|---|
| GRF-6-1/8" | 1-G 3/8" | 6-G 1/8" | 1 |
| GRF-6-1/4" | 1-G 3/8" | 6-G 1/4" | 1 |
| GRF-6-3/8" | 1-G 3/4" | 6-G 3/8" | 1 |

GRM - GIUNTO ROTANTE MASCHIO A SEI VIE
GRM - SIX WAY MALE ROTARY JOINT

| COD | ENTRATA - INLET | USCITA - OUTLET | 🛒 |
|------------|-----------------|-----------------|---|
| GRM-6-1/4" | 1-G 3/8" | 6-G 1/4" | 1 |
| GRM-6-3/8" | 1-G 3/4" | 6-G 3/8" | 1 |

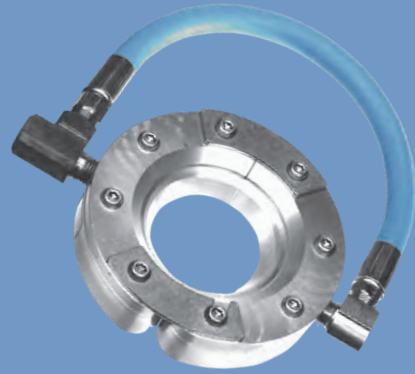
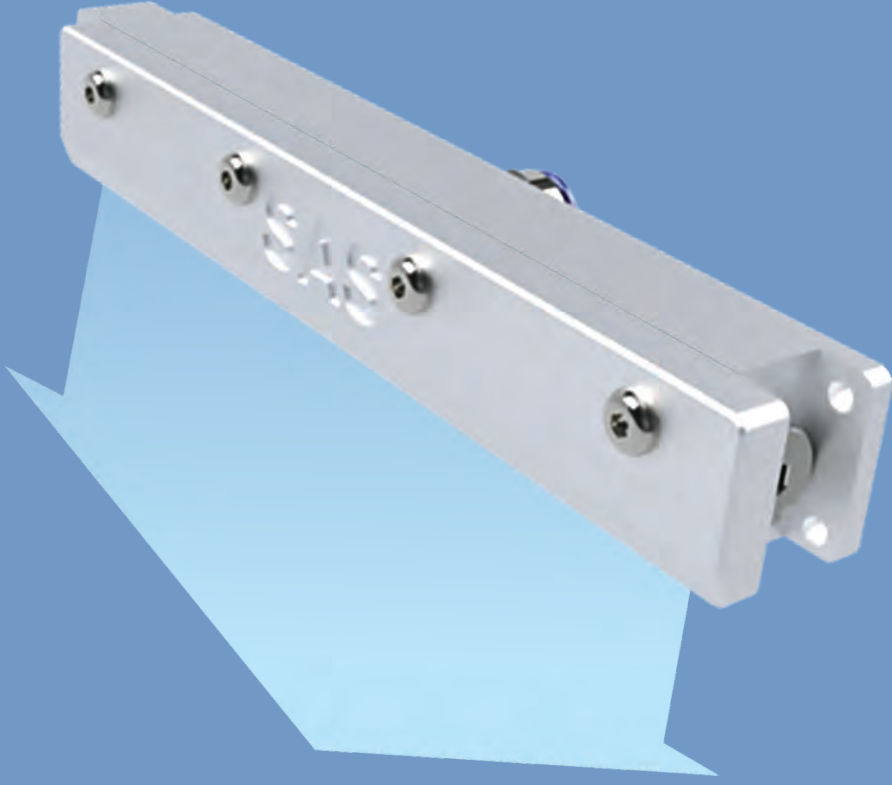

Per maggiori chiarimenti e specifiche consultare il relativo Fascicolo Tecnico.
For further clarifications and specifications, consult the relevant Technical File.



AIR WINGS

LAME D'ARIA MODULARI - MODULAR AIR WINGS

MODULAR AIR WINGS®

Le lame d'aria della SAS hanno una lunghezza standard di L= 150 mm: ciò consente una notevole economia nella gestione delle scorte di magazzino. Sono costruite utilizzando 3 diverse tipologie di materiale: PVC, Alluminio, Acciaio inossidabile **Aisi 316 L**. Sono fornibili in 2 versioni: tipo Standard (S) e tipo Coanda (C). Possono essere unite tra di loro fino ad ottenere la lunghezza desiderata (150-300-450-600 mm).

SAS Modular Air Wings® have a standard length of 150 mm. They can be mounted together in order to obtain the desired lengths. (150 - 300 - 450 - 600 mm). This allows you to manage warehouse stock more economically and rationally. Realized in three different materials: PVC, Aluminium, AISI 316 L. - Available in two versions: Standard type (S) and Coanda type (C).

| MODULAR AIR WINGS® | | |
|--------------------|-------------------------|---|
| COD | MATERIALE - MATERIAL | 🛒 |
| MAW - P | PVC - PVC | 1 |
| MAW - A | ALLUMINIO - ALUMINIUM | 1 |
| MAW - X | AISI 316 L - AISI 316 L | 1 |

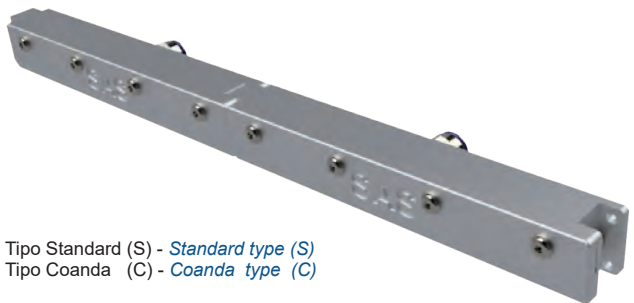

Tipo Standard (S) - *Standard type (S)*
Tipo Coanda (C) - *Coanda type (C)*



Standard = 150 mm - *Standard = 150 mm*
A richiesta L = 300 mm - *On request L = 300 mm*

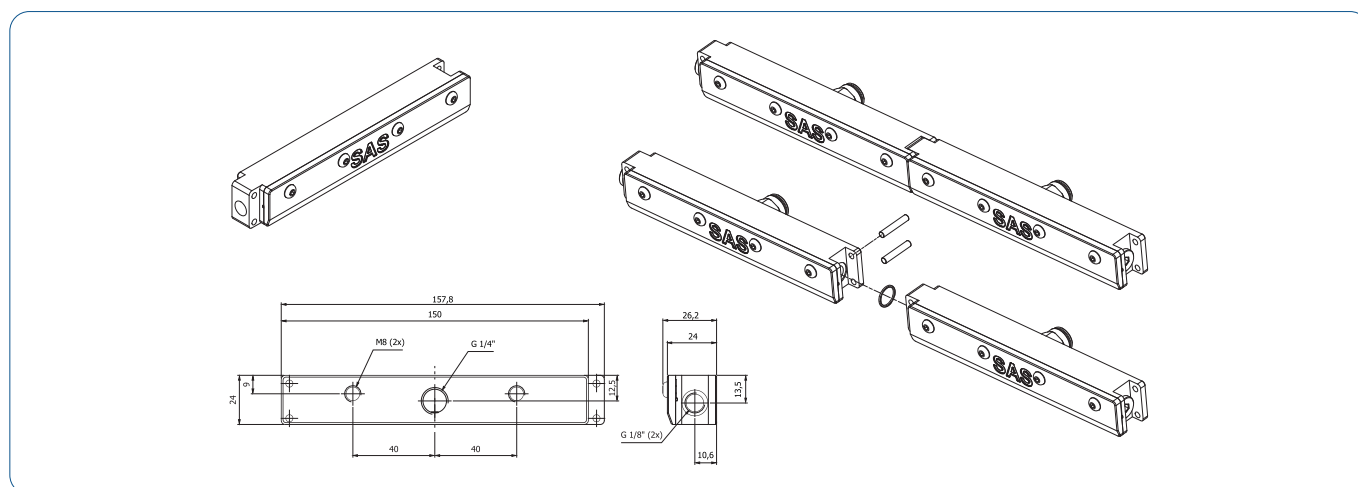

LAME D'ARIA STANDARD - STANDARD AIR BLADES



VISTA FRONTALE
FRONT VIEW

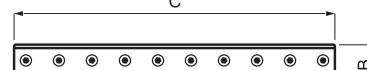

VISTA LATERALE
SIDE VIEW



| COD | A | B (mm) | C (mm) | L (mm) | 🛒 |
|----------|------|--------|--------|--------|---|
| SAW - A0 | 1/4" | 42 | 39 | 80 | 1 |
| SAW - A1 | 1/4" | 42 | 39 | 150 | 1 |
| SAW - A2 | 1/4" | 42 | 39 | 300 | 1 |
| SAW - A3 | 1/4" | 42 | 39 | 450 | 1 |
| SAW - A4 | 1/4" | 42 | 39 | 600 | 1 |
| SAW - X0 | 1/4" | 42 | 39 | 80 | 1 |
| SAW - X1 | 1/4" | 42 | 39 | 150 | 1 |
| SAW - X2 | 1/4" | 42 | 39 | 300 | 1 |
| SAW - X3 | 1/4" | 42 | 39 | 450 | 1 |
| SAW - X4 | 1/4" | 42 | 39 | 600 | 1 |

Materiali disponibili:
 SAW-A: Alluminio anodizzato blu
 SAW-X: Acciaio Inox **AISI 316 L**
 Available materials:
 SAW-A: Blue anodized aluminium
 SAW-X: Stainless steel **AISI 316 L**

LAME D'ARIA A BARRIERA - BARRIER AIR BLADES



Le lame d'aria a barriera in alluminio (LAB), a causa del volume d'aria di cui necessitano per il funzionamento, sono alimentate mediante una soffiante preposta. Sono disponibili in lunghezza da 100 mm a 5000 mm. Lunghezze non riportate nella seguente tabella sono fornibili a richiesta.

Aluminium Barrier Air Blades (LAB), due to the volume of air they need to be able to operate, are powered by a designated bower. They are available in lengths from 100 mm to 5000 mm. Other lengths: available on request.

| COD | L (mm) | 🛒 |
|----------|--------|---|
| LAB 100 | 100 | 1 |
| LAB 250 | 250 | 1 |
| LAB 500 | 500 | 1 |
| LAB 750 | 750 | 1 |
| LAB 1000 | 1000 | 1 |

LAME D'ARIA CIRCOLARI - ANELLI DI SOFFIAGGIO - RING BLADES - AIR WIPE SYSTEM

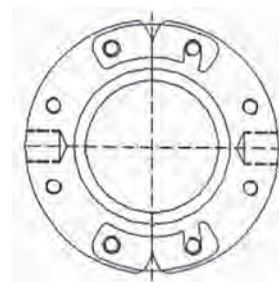
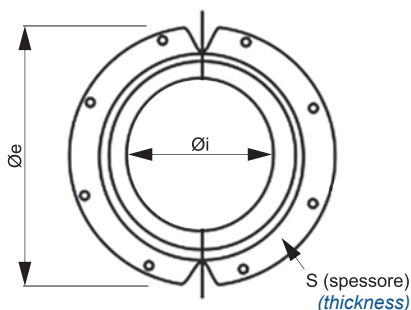

| ALLUMINIO ALUMINIUM | COD | Ø i (mm) Ø i (mm) | S (spessore / mm) S (Thickness / mm) | Ø e (mm) Ø e (mm) | Connessione Connection | 🛒 |
|------------------------|------------|----------------------|---|----------------------|---------------------------|---|
| | 1 LAC - AL | 13 | 38 | 152 | 1/4" | 1 |
| 2 LAC - AL | 25 | 38 | 152 | 1/4" | 1 | |
| 3 LAC - AL | 51 | 38 | 152 | 1/4" | 1 | |
| 4 LAC - AL | 76 | 38 | 152 | 1/4" | 1 | |
| 5 LAC - AL | 127 | 38 | 203 | 1/4" | 1 | |
| 6 LAC - AL | 178 | 38 | 254 | 1/4" | 1 | |

| AISI 316 L AISI 316 L | COD | Ø i (mm) Ø i (mm) | S (spessore / mm) S (Thickness / mm) | Ø e (mm) Ø e (mm) | Connessione Connection | 🛒 |
|--------------------------|-----------|----------------------|---|----------------------|---------------------------|---|
| | 1 LAC - X | 13 | 38 | 152 | 1/4" | 1 |
| 2 LAC - X | 25 | 38 | 152 | 1/4" | 1 | |
| 3 LAC - X | 51 | 38 | 152 | 1/4" | 1 | |
| 4 LAC - X | 76 | 38 | 152 | 1/4" | 1 | |
| 5 LAC - X | 127 | 38 | 203 | 1/4" | 1 | |
| 6 LAC - X | 178 | 38 | 254 | 1/4" | 1 | |

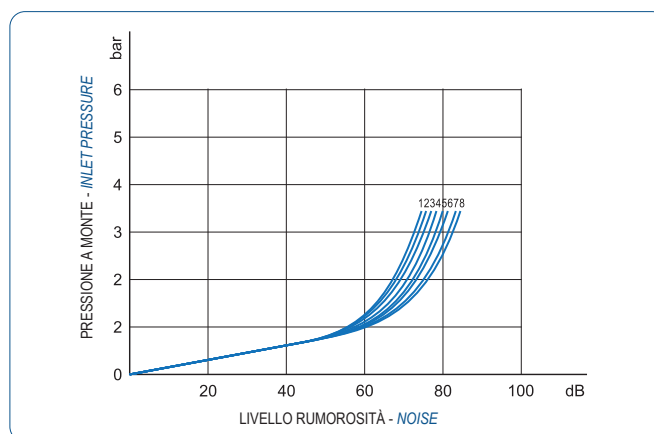
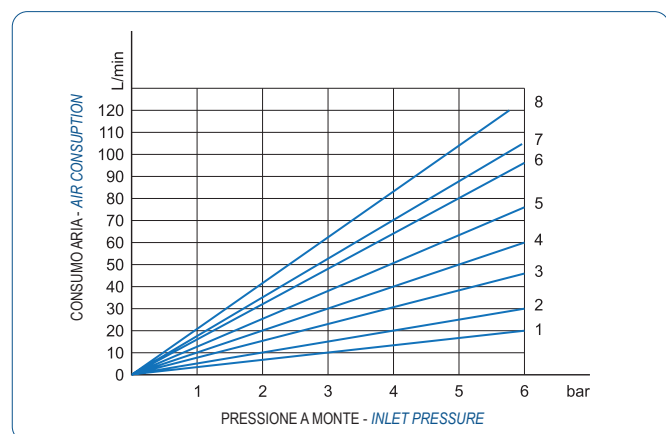

LAME D'ARIA CIRCOLARI - ANELLI DI SOFFIAGGIO

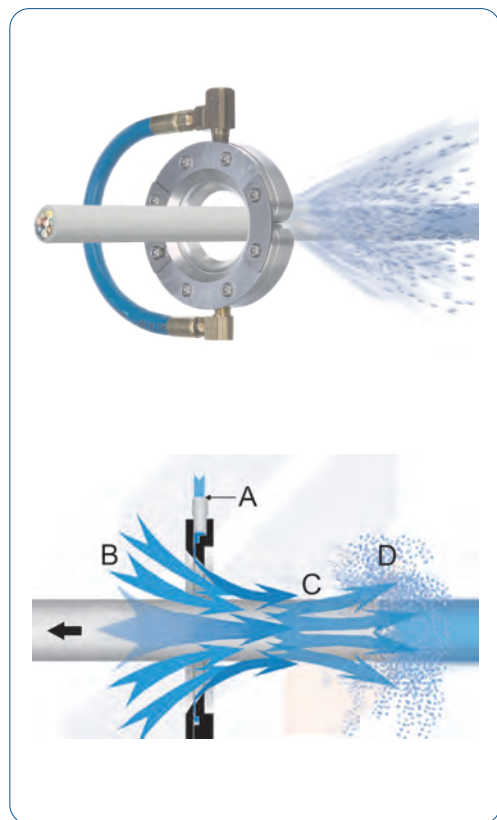

CARATTERISTICHE

Funzionano senza parti in movimento e senza utilizzo di elettricità. Vengono realizzate in alluminio e in acciaio **AISI 316 L**. Sono apribili completamente, costruite in due parti per consentire l'ingresso del materiale. Il flusso d'aria è abbondante e continuo lungo tutto lo sviluppo della lama. Sostituiscono tubi forati e ugelli, normalmente usati per pulizia, raffreddamento ed asciugatura. On-off istantaneo, senza parti in movimento e senza utilizzo di elettricità, evitando il pericolo d'esplosioni.

UTILIZZO

Le lame d'aria ad anello sono di semplice utilizzo e riducono il consumo d'aria compressa ed il livello di rumore. Producono un flusso "laminare" di aria lungo tutta la loro circonferenza a 360°, utilizzando l'effetto "Coanda", che "coinvolge" un grande volume di aria dall'area circostante, congiuntamente ad una piccola quantità di aria compressa proveniente dalla lama d'aria e producendo un flusso complessivo pari a 30 volte quello dell'aria compressa utilizzata. Con il risparmio realizzato nei consumi, il sistema ad anello si può ammortizzare molto rapidamente. Il sistema pulisce, raffredda ed asciuga cavi, corde e tubi.

BENEFICI

Di facile installazione e mantenimento, riducono il consumo energetico e quello di aria compressa rispetto ai sistemi tradizionali di simili applicazioni, quali tubi forati, anelli di getti d'aria o ugelli.

MODALITÀ DI APPLICAZIONE

Asciugatura tubi, cavi, fili e barre rettificata. Raffreddamento cavi. Rimozione di olio e polveri. Ideali in caso di estrusione di tubi, cavi e barre.

FUNZIONAMENTO DELLA LAMA D'ARIA CIRCOLARE

L'aria compressa entra dal punto A. L'aria ambiente viene trascinata nel punto B dal flusso dell'aria compressa che lascia la lama, attraverso la feritoia. L'aria coinvolta segue il profilo "Coanda" sulla fronte C della lama, che la spinge in linea retta, creando una parete uniforme di aria lungo tutto lo sviluppo della lama stessa. Il flusso d'aria così amplificato, in uscita dal punto D, incrementa la propria velocità e la forza viene utilizzata al massimo. Si ottiene così un flusso laminare di aria, utilizzando la minima quantità di energia, asciugando e rinfrescando il materiale da trattare.

AMPLIFICATORI DI FLUSSO D'ARIA



Gli amplificatori d'aria compressa sono dei semplici sistemi di aspirazione e soffiaggio che consentono, senza alcuna manutenzione, di convogliare fumi, materiali leggeri, muovere grandi quantità di aria per raffreddare, soffiare, o asciugare. Possono, in molte applicazioni, sostituire gli ugelli di soffiaggio anche di grandi dimensioni, riducendo così il consumo d'aria. Entrambe le estremità del sistema possono essere canalizzate per le esigenze dell'applicazione, come il portare aria fresca in un'area specifica, o per aspirare fumi pericolosi. Il flusso d'aria in uscita viene amplificato da 10 a 24 volte rispetto a quello in ingresso, mantenendo comunque un basso livello sonoro.

| | AD / AC 19 | AD / AC 32 | AD / AC 51 | AD / AC 102 |
|--------------------------|--|------------|------------|-------------|
| MATERIALE | Alluminio o AISI 304 | | | |
| INGRESSO | 1/8" | 1/4" | 3/8" | 1/2" |
| UTILIZZO | 3/4" | 1"1/4" | 2" | 4" |
| FLUIDO | Aria compressa lubrificata o non lubrificata | | | |
| FUNZIONAMENTO | Soffiaggio e aspirazione | | | |
| TEMPERATURA DI ESERCIZIO | - 20 °C + + 400 °C | | | |
| PRESSIONE DI ESERCIZIO | 0 + 7 Bar | | | |

| PRESTAZIONI A 5,5 BAR | | | | |
|-----------------------|----------|-------------------------|----------------------------------|----------------------------|
| MODELLO | INGRESSO | CONSUMO D'ARIA (NL/min) | AMPLIFICAZIONE (NUMERO DI VOLTE) | PORTATA IN USCITA (NL/min) |
| AD / AC 19 | 1/8" | 263 | 10 | 2634 |
| AD / AC 32 | 1/4" | 370 | 16 | 5819 |
| AD / AC 51 | 3/8" | 606 | 20 | 12121 |
| AD / AC 102 | 1/2" | 1424 | 24 | 34182 |

RING BLADES - AIR WIPE SYSTEM

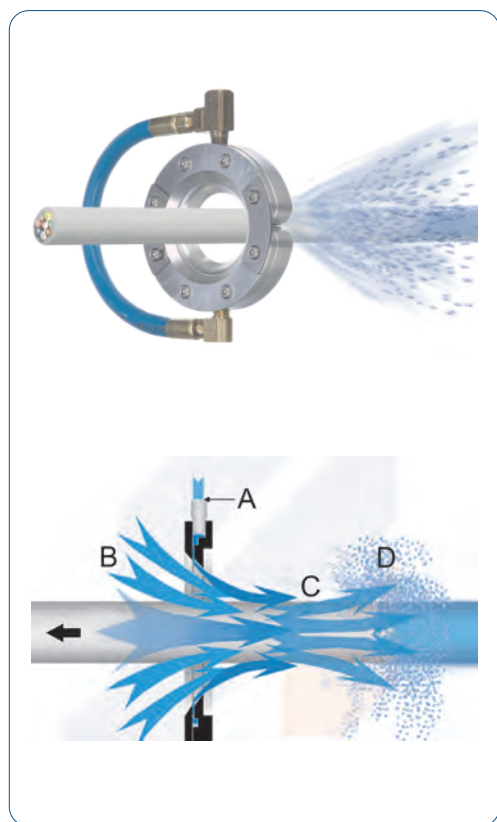

FEATURES

No moving parts - Gold Anodized aluminum, Hard Anodized aluminum or 316 L stainless steel. Compact design, simple, lightweight and portable. Full Flow Split Design - Air across entire length of Air Knife. Air inlets at ends and back. Driven by air not electricity. High airflow amplification. Instant on-off, no electricity or explosion hazard.

REASON TO USE

Ring Blade from SAS is easy to mount and maintain, and reduces both compressed air consumption and noise levels. It produces a "laminar" flow of air along its 360 angle using the "Coanda" effect which "entrains" a large volume of air from the surrounding area along with the small amount of compressed air from the Ring Blade™ air-saver wiper-blade to produce an output flow up to 30 times. The Ring Blade air wipe blowoff system payback on compressed air savings can be as short as a few weeks when compared to nozzle "rings" or simple annular slots used by other air wiping systems. Blowoff, cool, and clean products such as cable, pipe, wire and hose.

BENEFITS

Longer life in difficult environments for aluminum models because of anodizing, 316L stainless models for high temperature and corrosive environments. Easy to install and maintain and allows removal of a continuous piece. Even blowoff around the part, lightweight and compact. Lower compressed air consumption than a ring of drilled pipe or ring of open jets and nozzles. Maintenance free with output easily controlled, safe to use.

SYSTEM APPLICATIONS

Blowoff of dust, liquid, contaminants and uniformly wipe surfaces. Dry after washing, plating or coating. Cool hot surfaces. Dry extruded profiles, plastic tubing, hose, wire, fiber optics, ribbon, strips. Prevent solution carryover and avoid cross contamination. Clean paint gun tips. Remove access water, coatings, oil.

HOW IT WORKS

Compressed air enters at point (A) into an annular chamber and throttled through a small ring nozzle at high velocity. This air stream clings to the "coanda" profile directing the air stream down toward the surface which is angled to create a "cone" style directed force to best clean, wipe and dry a surface. The surrounding air is entrained at point (B) creating an amplified 360 degree conical airflow at point (C) to uniformly wipe the surface of the material running through the Ring Blade. The wet or dirty material (D) direction of travel is against the flow.

AIR FLOW AMPLIFIERS



The compressed air amplifiers are simple suction and blowing systems that allow, without any maintenance, to convey fumes, light materials, move large quantities of air to cool, blow, or dry. They can, in many applications, replace blowing nozzles even of large dimensions, thus reducing air consumption.

Both ends of the system can be channeled for application needs, such as bringing fresh air to a specific area, or to suck up dangerous fumes. The output air flow is amplified 10 to 24 times compared to the input air, maintaining however a low sound level.

| | AD / AC 19 | AD / AC 32 | AD / AC 51 | AD / AC 102 |
|-----------------------|---|------------|------------|-------------|
| MATERIAL | Aluminium - AISI 304 | | | |
| INPUT | 1/8" | 1/4" | 3/8" | 1/2" |
| USE | 3/4" | 1"1/4" | 2" | 4" |
| FLUID | Lubricated or non-lubricated compressed air | | | |
| OPERATION | Blowing and suction | | | |
| OPERATING TEMPERATURE | - 20 °C ÷ + 400 °C | | | |
| OPERATING PRESSURE | 0 ÷ 7 Bar | | | |

| PERFORMANCES AT 5,5 BAR | | | | |
|-------------------------|-------|--------------------------|-----------------------|--------------------|
| MODELL | INPUT | AIR CONSUMPTION (NL/min) | AMPLIFICATION (TIMES) | FLOW RATE (NL/min) |
| AD / AC 19 | 1/8" | 263 | 10 | 2634 |
| AD / AC 32 | 1/4" | 370 | 16 | 5819 |
| AD / AC 51 | 3/8" | 606 | 20 | 12121 |
| AD / AC 102 | 1/2" | 1424 | 24 | 34182 |

AMPLIFICATORI DI FLUSSO D'ARIA - AIR FLOW AMPLIFIERS

Tipo AD:
DIFFUSORE
AD-A: Alluminio
AD-X: AISI 304

AD Type:
DIFFUSER
AD-A: Aluminium
AD-X: AISI 304



| ALLUMINIO ALUMINIUM | COD | | 🛒 | |
|------------------------|------|-----|---|---|
| | AD-A | 19 | | 1 |
| | AD-A | 32 | | 1 |
| | AD-A | 51 | | 1 |
| | AD-A | 102 | | 1 |

| AIS I 304 AIS I 304 | COD | | 🛒 | |
|------------------------|------|-----|---|---|
| | AD-X | 19 | | 1 |
| | AD-X | 32 | | 1 |
| | AD-X | 51 | | 1 |
| | AD-X | 102 | | 1 |

Tipo AC:
CANALIZZATO
AC-A: Alluminio
AC-X: AISI 304

AC Type:
CANALIZED
AC-A: Aluminium
AC-X: AISI 304



| ALLUMINIO ALUMINIUM | COD | | 🛒 | |
|------------------------|------|-----|---|---|
| | AC-A | 19 | | 1 |
| | AC-A | 32 | | 1 |
| | AC-A | 51 | | 1 |
| | AC-A | 102 | | 1 |

| AIS I 304 AIS I 304 | COD | | 🛒 | |
|------------------------|------|-----|---|---|
| | AC-X | 19 | | 1 |
| | AC-X | 32 | | 1 |
| | AC-X | 51 | | 1 |
| | AC-X | 102 | | 1 |

Tipo AD: DIFFUSORE
AD Type: DIFFUSER

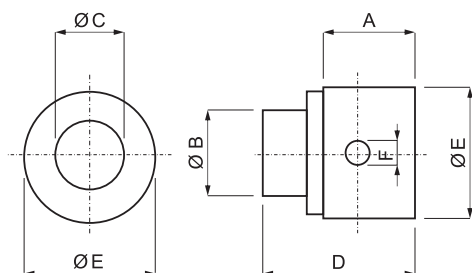

| COD | A | B | C | D | E | F |
|----------|------|-------|--------|-------|--------|------|
| AD-A 19 | 48,5 | Ø 19 | Ø 13 | 84,5 | Ø 43 | 1/8" |
| AD-A 32 | 65 | Ø 32 | Ø 24,5 | 106 | Ø 58,5 | 1/4" |
| AD-A 51 | 61 | Ø 51 | Ø 42 | 129,5 | Ø 77,8 | 3/8" |
| AD-A 102 | 76 | Ø 100 | Ø 86 | 165 | Ø 140 | 1/2" |

| COD | A | B | C | D | E | F |
|----------|------|-------|--------|-------|--------|------|
| AD-X 19 | 48,5 | Ø 19 | Ø 13 | 84,5 | Ø 43 | 1/8" |
| AD-X 32 | 65 | Ø 32 | Ø 24,5 | 106 | Ø 58,5 | 1/4" |
| AD-X 51 | 61 | Ø 51 | Ø 42 | 129,5 | Ø 77,8 | 3/8" |
| AD-X 102 | 76 | Ø 100 | Ø 86 | 165 | Ø 140 | 1/2" |

Tipo AC: CANALIZZATO
AC Type: CANALIZED

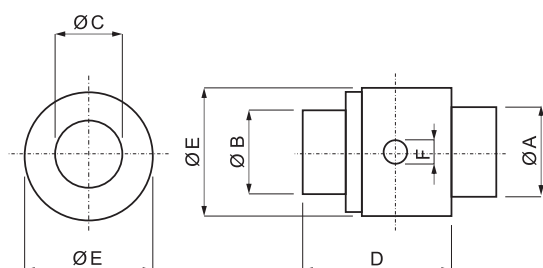

| COD | A | B | C | D | E | F |
|----------|-------|-------|--------|-------|--------|------|
| AC-A 19 | Ø 19 | Ø 19 | Ø 13 | 84,5 | Ø 43 | 1/4" |
| AC-A 32 | Ø 32 | Ø 32 | Ø 24,5 | 106 | Ø 58,5 | 3/8" |
| AC-A 51 | Ø 51 | Ø 51 | Ø 42 | 129,5 | Ø 77,8 | 3/8" |
| AC-A 102 | Ø 100 | Ø 100 | Ø 86 | 165 | Ø 140 | 1/2" |

| COD | A | B | C | D | E | F |
|----------|-------|-------|--------|-------|--------|------|
| AC-X 19 | Ø 19 | Ø 19 | Ø 13 | 84,5 | Ø 43 | 1/4" |
| AC-X 32 | Ø 32 | Ø 32 | Ø 24,5 | 106 | Ø 58,5 | 3/8" |
| AC-X 51 | Ø 51 | Ø 51 | Ø 42 | 129,5 | Ø 77,8 | 3/8" |
| AC-X 102 | Ø 100 | Ø 100 | Ø 86 | 165 | Ø 140 | 1/2" |

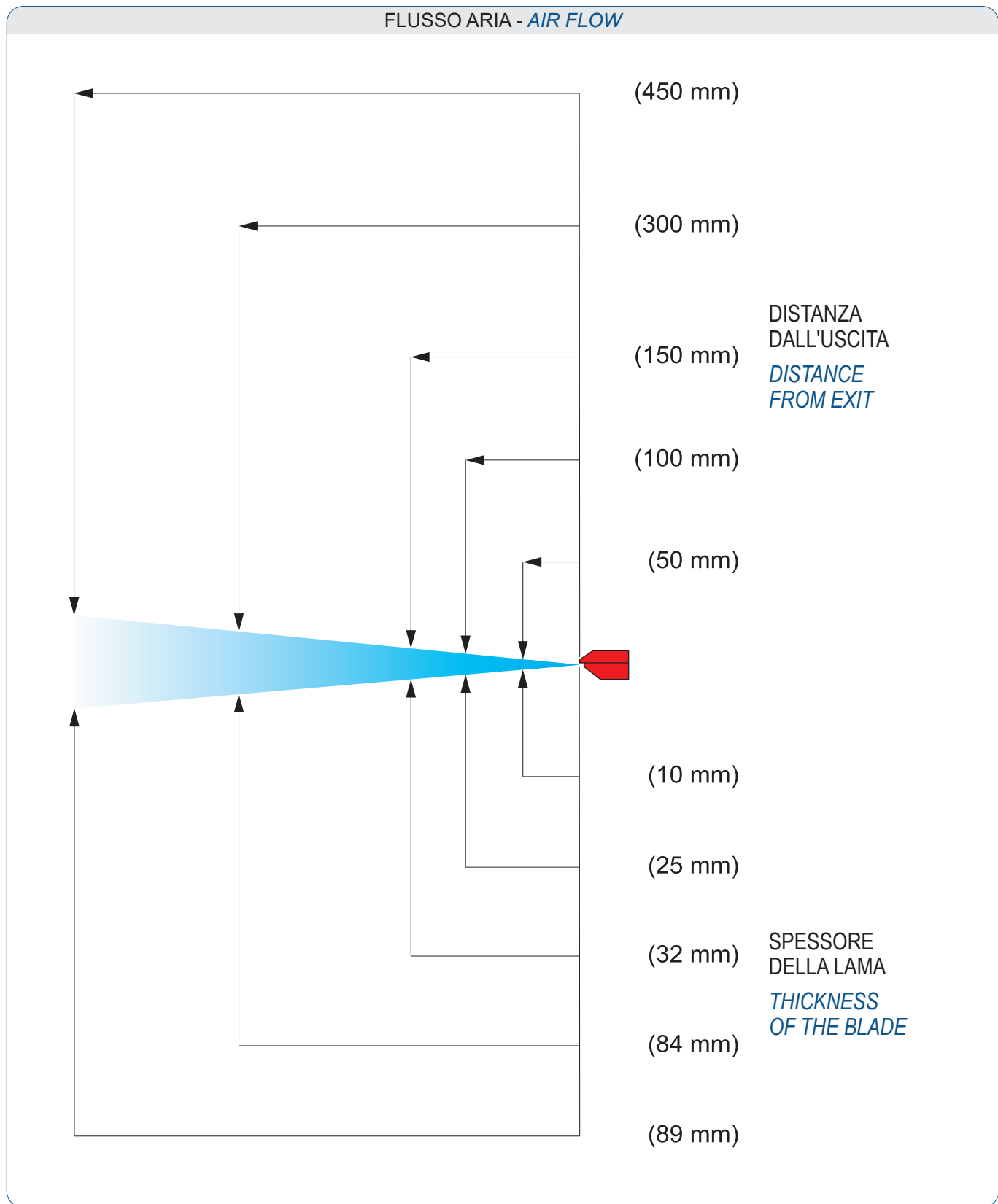

Per maggiori chiarimenti e specifiche consultare il relativo Fascicolo Tecnico.
 For further clarifications and specifications, consult the relevant Technical File.

LAME D'ARIA MODULARI - MODULAR AIR WINGS®



LAME D'ARIA STANDARD - STANDARD AIR BLADES



LAME D'ARIA A BARRIERA - BARRIER AIR BLADES



LAME D'ARIA CIRCOLARI - ANELLI DI SOFFIAGGIO - RING BLADES - AIR WIPE SYSTEM

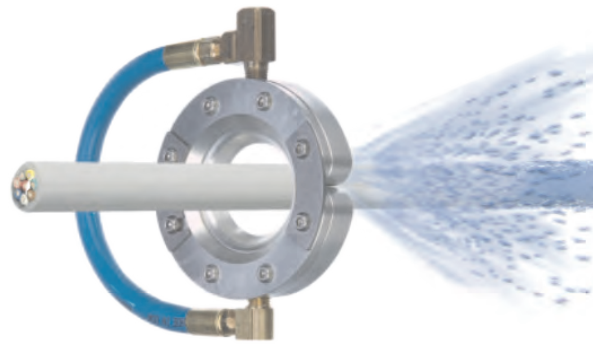

AMPLIFICATORI DI FLUSSO D'ARIA - AIR FLOW AMPLIFIERS



Tipo AD:
DIFFUSORE
AD Type:
DIFFUSER



Tipo AC:
CANALIZZATO
AC Type:
CANALIZED

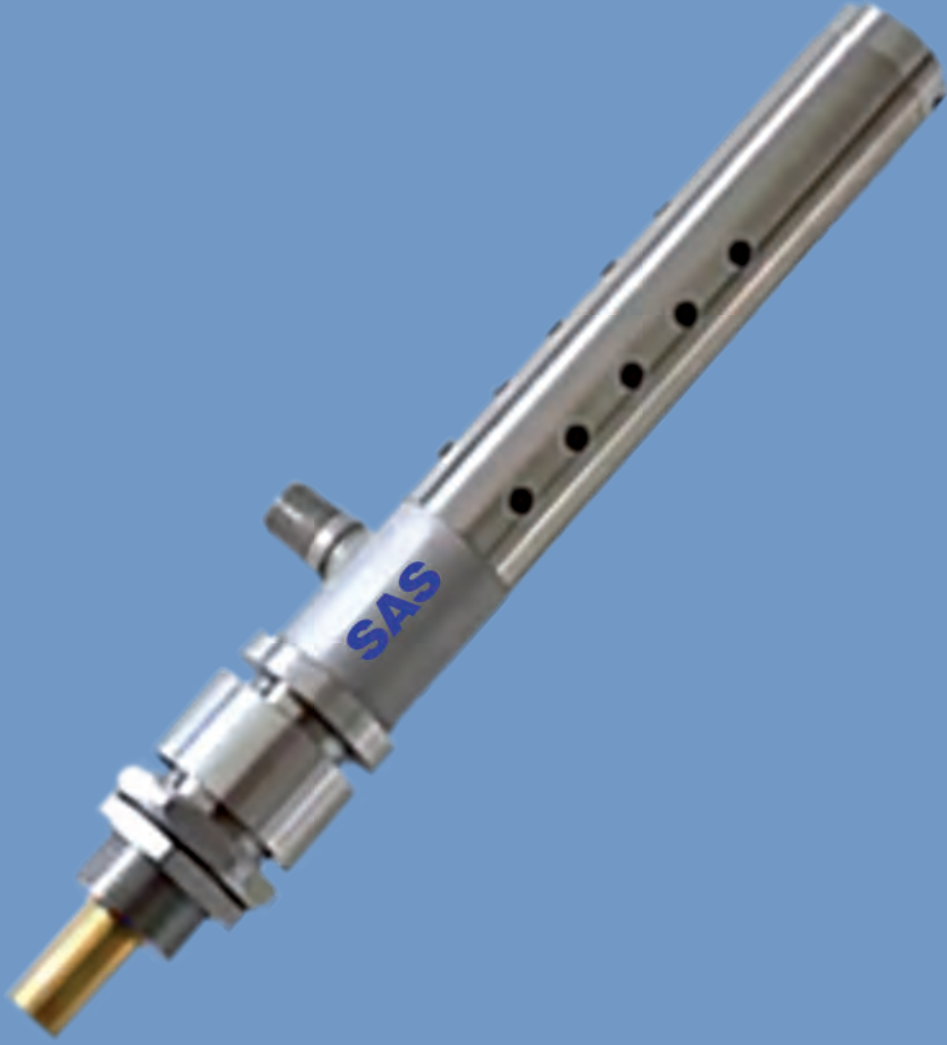

ICE VALVE - PANEL COOLER

ICE VALVE PANEL COOLER



AISI 316 L

| COD | POTENZA REFRIGERANTE | 🛒 |
|--------|----------------------|---|
| IV 42 | 42 Watt | 1 |
| IV 85 | 85 Watt | 1 |
| IV 170 | 170 Watt | 1 |
| IV 214 | 214 Watt | 1 |
| IV 322 | 322 Watt | 1 |
| IV 527 | 527 Watt | 1 |
| IV 615 | 615 Watt | 1 |
| IV 849 | 849 Watt | 1 |

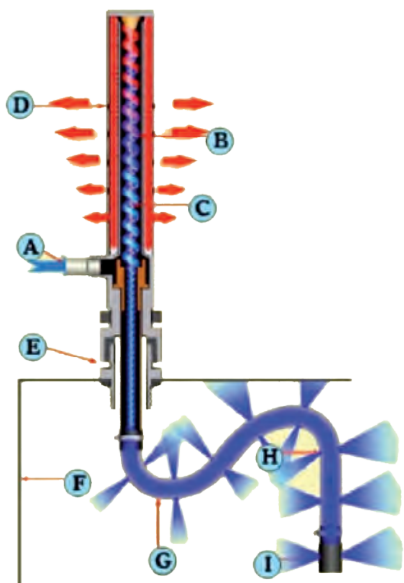
**REFRIGERATORE PER QUADRI ELETTRICI**

L'aria compressa entra nel Tubo Vortex (punto A) e genera due correnti: una calda (B) ed una fredda.

Quella calda viene espulsa all'esterno tramite il dispositivo (D) riducendo il livello sonoro dell'emissione.

L'aria calda che si trova all'interno del quadro elettrico (F) viene espulsa in atmosfera attraverso il punto (E).

L'aria fredda entra nel quadro elettrico (F) tramite il tubo di distribuzione (G).

I fori (H) esistenti sul tubo di distribuzione hanno il compito di indirizzare l'aria fredda nelle corrette direzioni.

Sul terminale del tubo è posizionato un silenziatore che ha il compito di ridurre il livello sonoro dell'aria in uscita.

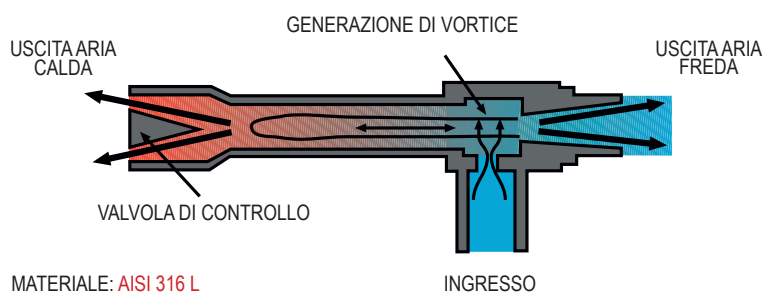

MATERIALE: AISI 316 L

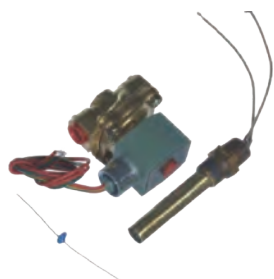
**VALVOLA SOLENOIDE E TERMOSTATO**

I sistemi PANEL COOLER vengono forniti con un Kit di regolazione (valvola a 2 vie NC + termostato) che ha il compito di regolare al minimo necessario il consumo di aria compressa.

Modello A: 120 V - Modello B: 230 V

Il termostato viene fornito pre-settato a 35 °C (+/- 2 °C) con la possibilità di scelta tra 24VAC/240VAC e 0/60 Hz. Sono dotati di certificazione Atex (a richiesta UR).

KIT TERMOSTATO E VALVOLA SOLENOIDE

Il Kit viene fornito dotato di una resistenza che, in presenza di eventuali rapide fluttuazioni di temperatura all'interno del Quadro Elettrico, ha il compito di far intervenire il solenoide riducendo la sensibilità del termostato per evitare cicli troppo rapidi.



IN = 3/8

| COD | 🛒 |
|-----------|---|
| FAC - 5 µ | 1 |

FILTRO ANTI CONDENSA 5 µ

Se ne consiglia l'utilizzo nel punto di entrata dell'aria compressa al fine di eliminare i residui di condensa presenti nel circuito di alimentazione per evitare il rischio di formazione di ghiaccio nei punti di uscita dell'aria fredda.

| | COD | CAPACITY | 🛒 |
|---|--------|----------|---|
|  <p>AISI 316 L</p> | IV 42 | 42 Watt | 1 |
| | IV 85 | 85 Watt | 1 |
| | IV 170 | 170 Watt | 1 |
| | IV 214 | 214 Watt | 1 |
| | IV 322 | 322 Watt | 1 |
| | IV 527 | 527 Watt | 1 |
| | IV 615 | 615 Watt | 1 |
| | IV 849 | 849 Watt | 1 |

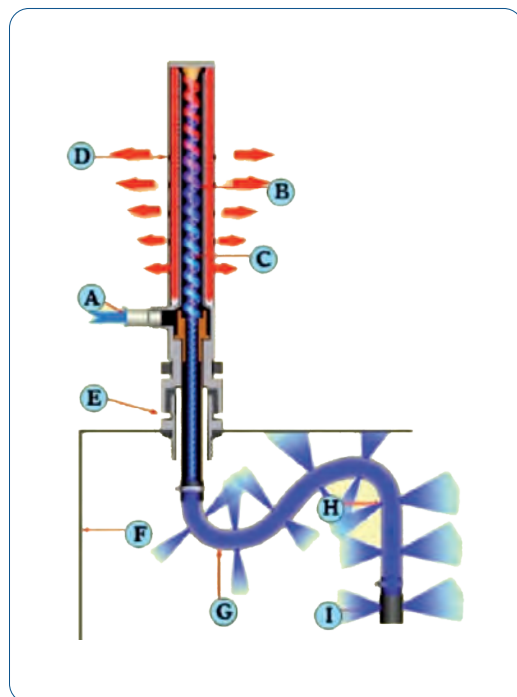

PANEL COOLER SYSTEM - HOW IT WORKS

Compressed air enters at point (A) into the vortex tube component of the panel cooler. The vortex tube splits the compressed air into a hot (B) and cold (C) streamofair.

The hot air from the vortex tube is vented to the atmosphere at point (D) after being muffled to reduce noise. Hot air displaced from inside the control panel or cabinet is exhausted through point (E). Cold air enters into the panel (F) via the cold distribution hose (G).

Holes (H) are punched into the hose kit to deliver the cold air inside the panel where required. A muffler (I) further reduces the noise level of the exhausting air.

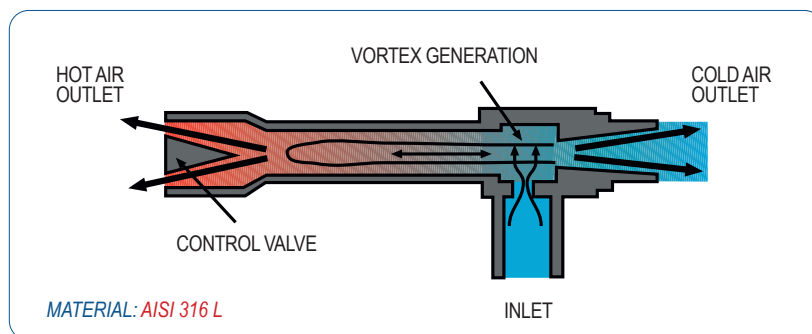

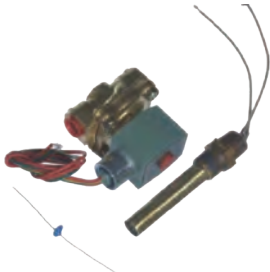
| | COD | 🛒 |
|---|---|---|
|  | KIT-IV | 1 |
| | <p>SOLENOID VALVE AND THERMOSTAT</p> <p>Compressed air enters at point (A) into the vortex tube component of the panel cooler. The vortex tube splits the compressed air into a hot (B) and cold (C) streamofair. The hot air from the vortex tube is vented to the atmosphere at point (D) after being muffled to reduce noise. Hot air displaced from inside the control panel or cabinet is exhausted through point (E). Cold air enters into the panel (F) via the cold distribution hose (G). Holes (H) are punched into the hose kit to deliver the cold air inside the panel where required. A muffler (I) further reduces the noise level of the exhausting air.</p> <p>THERMOSTAT AND SOLENOID VALVE KIT</p> <p>The kit comes complete with a solenoid valve, thermostat and a resistor. The resistor is included should you encounter rapid temperature fluctuations in the control panel causing the solenoid to cycle on and off too quickly (chattering). The resistor is installed (if needed) across the leads of the thermostat and prevents chattering by dampening the thermo switch sensitivity.</p> | |

| | COD | 🛒 |
|---|--|---|
|  <p>IN = 3/8</p> | FAC - 5 μ | 1 |
| | <p>ANTI-CONDENSATION FILTER 5 μ</p> <p>It's recommended to use the compressed air inlet point in order to eliminate the residual condensate present in the supply circuit to avoid the risk of ice formation in the cold air outlet points.</p> | |



Per maggiori chiarimenti e specifiche consultare il relativo Fascicolo Tecnico.
For further clarifications and specifications, consult the relevant Technical File.

A large grid of graph paper for taking notes, consisting of 20 columns and 30 rows of small squares.



PNEUMATIC CONTROL

ATTUATORI - ACTUATORS

ATTUATORI PNEUMATICI 90° IN ALLUMINIO - SEMPLICE / DOPPIO EFFETTO
SINGLE / DOUBLE ACTING 90° ALUMINIUM PNEUMATIC ACTUATORS



CORPO IN ALLUMINIO STANDARD 90° - 120° / 180° A RICHIESTA
** A RICHIESTA MODELLO AD ALTA TEMPERATURA HT
(RANGE - 20°C + + 150°C)
ESEMPIO: AT032SE HT - AT032DE HT

BODY: ALUMINIUM
STANDARD TYPE: 90° - 120°/180°: ON REQUEST
** AVAILABLE ON REQUEST:
HIGH TEMPERATURE TYPE (RANGE - 20°C + + 150°C)
EXAMPLE: AT032SE HT - AT032DE HT

| COD | 🛒 | € | ** | COD | 🛒 | ** |
|---------|---|---|----|---------|---|----|
| AT032SE | 1 | | ** | AT032DE | 1 | ** |
| AT040SE | 1 | | ** | AT040DE | 1 | ** |
| AT052SE | 1 | | ** | AT052DE | 1 | ** |
| AT063SE | 1 | | ** | AT063DE | 1 | ** |
| AT075SE | 1 | | ** | AT075DE | 1 | ** |
| AT083SE | 1 | | ** | AT083DE | 1 | ** |
| AT092SE | 1 | | ** | AT092DE | 1 | ** |
| AT105SE | 1 | | ** | AT105DE | 1 | ** |
| AT125SE | 1 | | ** | AT125DE | 1 | ** |
| AT140SE | 1 | | ** | AT140DE | 1 | ** |
| AT160SE | 1 | | | AT160DE | 1 | |
| AT190SE | 1 | | | AT190DE | 1 | |
| AT210SE | 1 | | | AT210DE | 1 | |
| AT240SE | 1 | | | AT240DE | 1 | |
| AT270SE | 1 | | | AT270DE | 1 | |
| AT300SE | 1 | | | AT300DE | 1 | |
| AT350SE | 1 | | | AT350DE | 1 | |
| AT400SE | 1 | | | AT400DE | 1 | |

ATTUATORI PNEUMATICI IN TECNOPOLIMERO - *TECHNOPOLYMER PNEUMATIC ACTUATORS*

| COD | E | L | N | 🛒 |
|--------|-----|-----|-----|---|
| AT-P01 | 135 | 112 | 96 | 1 |
| AT-P02 | 145 | 142 | 118 | 1 |
| AT-P03 | 168 | 170 | 141 | 1 |
| AT-P04 | 229 | 204 | 169 | 1 |
| AT-P05 | 285 | 230 | 206 | 1 |



IN TECNOPOLIMERO
PER AMBIENTI CORROSIVI
*FOR USE IN CORROSIVE
ENVIRONMENTS*

TECNOPOLIMERO
TECHNOPOLYMER

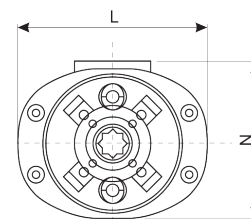
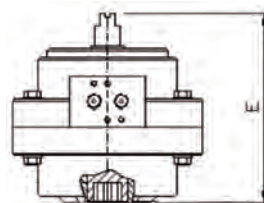

DATI TECNICI - *TECHNICAL DATA*

| COD | COPIA USCITA (Nm) - <i>OUTPUT TORQUE (Nm)</i> | | | | | | | | |
|--------|---|-------|-------|-------|-------|-------|-------|-------|--------|
| | 2 bar | 3 bar | 4 bar | 5 bar | 6 bar | 7 bar | 8 bar | 9 bar | 10 bar |
| AT-P01 | 8 | 12 | 18 | 24 | 30 | 36 | 42 | 48 | 54 |
| AT-P02 | 12 | 24 | 36 | 48 | 60 | 72 | 84 | 96 | 108 |
| AT-P03 | 35 | 60 | 85 | 110 | 135 | 160 | 185 | 210 | 235 |
| AT-P04 | 80 | 135 | 190 | 245 | 300 | 355 | 410 | 465 | 520 |
| AT-P05 | 180 | 310 | 440 | 570 | 700 | 830 | 960 | 1090 | 1220 |

CARATTERISTICHE - *FEATURES*

MATERIALI UTILIZZATI:
Acciaio Inossidabile **AISI 304** - Nylon 6,6 caricato con fibra di vetro (50%)
Temperatura di esercizio: - 20°C + +110°C - Pressione max 10 bar - Meccanismo a Palmola - Doppio effetto - Atex a richiesta
I materiali utilizzati permettono l'utilizzo di questo attuatore negli ambienti corrosivi in genere ed in particolare:
Industrie chimiche - Raffinerie - Impianti marini - Piscine - Industria alimentare Industrie enologiche - Settore farmaceutico - Settore sanitario - Settore cosmetico.
DISPONIBILE A RICHIESTA VALVOLA NAMUR MONOSTABILE DA 1/4" IN **AISI 316**

MATERIALS:
Stainless steel AISI 304 - Nylon 6,6 with fiber glass (50%)
Operating temperature: - 20°C + +110°C - Max pressure: 10 bar - Palmola Mechanism - Double acting - Atex on request
The materials used allow the use of these actuators for all corrosive environments.
Chemical industries - Refineries - Marine plants - Swimming pools - Wine industries - Pharmaceutical sector - Health sector - Cosmetic sector.
AVAILABLE ON REQUEST 1/4" **AISI 316** NAMUR VALVE

ATTUATORI - ACTUATORS

ATTUATORI PNEUMATICI ACCIAIO INOX AISI 316 L - AISI 316 L STAINLESS STEEL PNEUMATIC ACTUATORS



AISI 316 L

| COD | 🛒 | COD | 🛒 |
|--------------|---|--------------|---|
| AT045SE - X | 1 | AT045DE - X | 1 |
| AT052SE - X | 1 | AT052DE - X | 1 |
| AT063SE - X | 1 | AT063DE - X | 1 |
| AT083SE - X | 1 | AT083DE - X | 1 |
| AT0105SE - X | 1 | AT0105DE - X | 1 |
| AT0125SE - X | 1 | AT0125DE - X | 1 |
| AT0140SE - X | 1 | AT0140DE - X | 1 |
| AT0160SE - X | 1 | AT0160DE - X | 1 |
| AT0210SE - X | 1 | AT0210DE - X | 1 |

ATTUATORI ELETTRICI - ELECTRIC ACTUATORS



ALLUMINIO - ALUMINIUM

| COD | 🛒 |
|----------|---|
| ATEP 03 | 1 |
| ATEP 05 | 1 |
| ATEP 10 | 1 |
| ATEP 20 | 1 |
| ATEP 40 | 1 |
| ATEP 60 | 1 |
| ATEP 100 | 1 |
| ATEP 200 | 1 |

SENSORI FINE CORSA - LIMIT SWITCHES

MECCANICO
MECHANIC



COD SFC 1



INDUTTIVO
INDUCTIVE



COD SFC -V3 1



ATEX - ATEX

INDUTTIVO
CON MORSETTIERA
INDUCTIVE WITH
TERMINAL BLOCK



COD PEPPERL F25 1



INDUTTIVO
CON MORSETTIERA
INDUCTIVE WITH
TERMINAL BLOCK



COD PEPPERL F31 1



ATEX - ATEX

DL - INDICATORE DI LIVELLO
LEVEL INDICATOR



CONTATTI: NC - NA A RICHIESTA
CONTACTS: NC - NO (ON REQUEST)

1



TECNOPOLIMERO
TECHNOPOLYMER

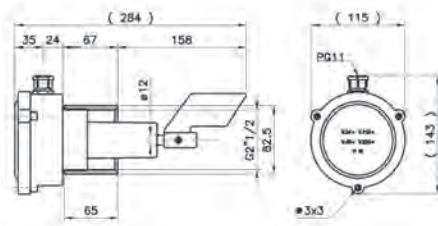

POSIZIONATORE
ROTATIVO
ROTARY
POSITIONER



COD PR 1



ATTUATORI - ACTUATORS

DESCRIZIONE DEL SISTEMA

Trattasi di attuatore pneumatico che opera con pignone e cremagliera con funzionamento a doppio effetto, mediante ingresso di aria compressa, e a semplice effetto con la presenza di molle precomprese:

Corpo attuatore in lega di alluminio estruso - Pignone di alta precisione in acciaio - Pistoni in alluminio pressofuso con anodizzazione dura.

Doppio registro di regolazione di 5° - Fori superiori per fissaggio accessori - Fluido aria secca o lubrificata - Alimentazione 2-10 bar

Range di funzionamento temperatura ambiente - 40°C + 50°C.

SYSTEM DESCRIPTION

This is a pneumatic actuator that operates with a pinion and rack with double-acting operation, through the input of compressed air, and simple effect with the presence of pre-compressed springs:

Extruded aluminum alloy actuator body - High precision steel pinion - Die-cast aluminum pistons with hard anodizing. Double adjustment register of 5 millimeters. -

Upper holes for fixing accessories - Dry or lubricated air fluid - Power supply 2-10 bar

Operating range ambient temperature - 40°C + 50°C.

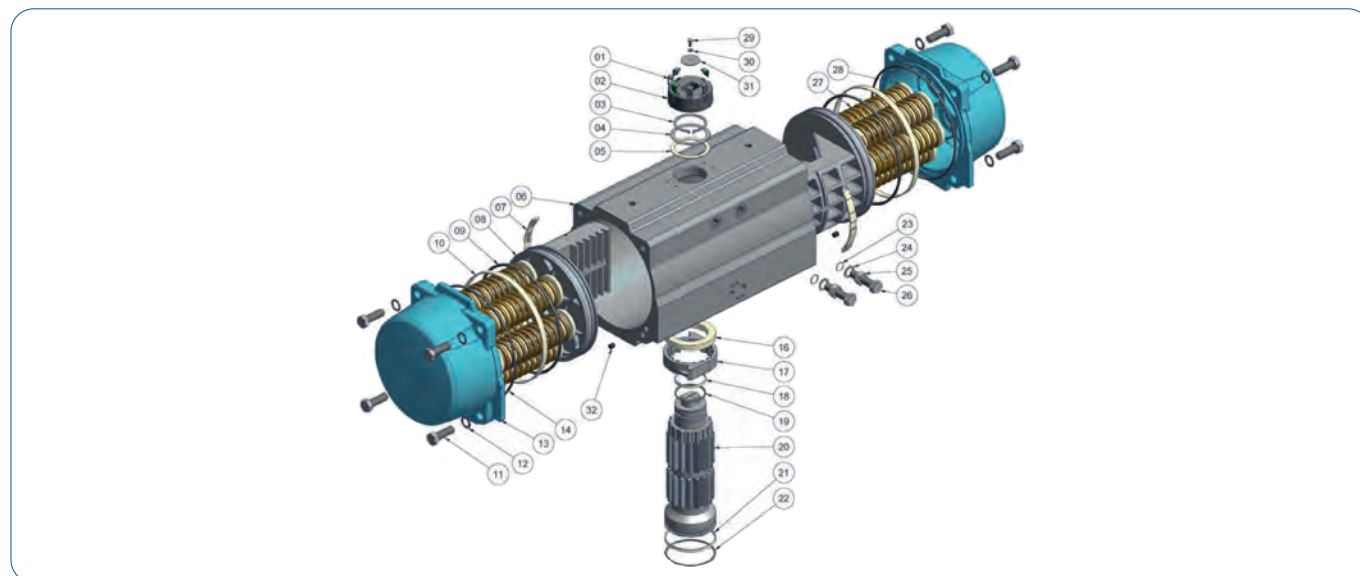

| N. | DESCRIZIONE | DESCRIPTION | MATERIALI | MATERIALS |
|------------------|-----------------------------------|-------------------------|---|---|
| 01 | Indicatori | Indicators | PP GF30 | PP GF30 |
| 02 | Tappo | Cap | PP GF30 | PP GF30 |
| 03* | Anello elastico | Spring clip (pinion) | Acciaio Inox / S.S. | Stainless Steel |
| 04* ^A | Rondella | Thrust Washer (pinion) | Acciaio Inox / S.S. | Stainless Steel |
| 05* | Bussola esterna | External bearing gasket | PPA | PPA |
| 06 | Corpo (anodizzato) | Body (anodized) | AL 6005 (estruso) | AL 6005 (Extruded) |
| 07* | Anello guida pistone | Piston bush | Nylon 6.6 | Nylon 6.6 |
| 08 | Pistone | Piston | AL 6005 (P. Fuso) | AL 6005 (Die cast) |
| 09* | O-Ring (Pistone) | O-Ring (Piston) | NBR 70 - | NBR 70 |
| 10* | Anello Pistone | Piston bearing | PPA - | PPA |
| 11 | Vite | Bolt | Acciaio Inox / S.S. | Stainless Steel |
| 12 | Rondella | Flat gasket | Acciaio Inox / S.S. | Stainless Steel |
| 13 | Culatta (Rivestimento poliestere) | End (Polyester coating) | AL 6005 | AL 6005 |
| 14* | O-Ring (culatta) | O-Ring (End cap) | NBR 70 | NBR 70 |
| 16* | Bussola interna | Internal bearing gasket | PPA | PPA |
| 17 | Camma | Travel adjuster | Acciaio Inox / S.S. | Stainless Steel |
| 18* | Boccola superiore pignone | Top pinion bearing | PPA | PPA |
| 19* | O-Ring (superiore pignone) | O-Ring (Pinion top) | NBR 70 | NBR 70 |
| 20 | Pignone | Pinion | APM 102+APM 287: Acciaio Inox / S.S. APM 305+APM 900: C 45 | APM 102+APM 287: Stainless Steel APM 305+APM 900: C 45 |
| 21* | Boccola inferiore pignone | Bottom pinion bearing | PPA | PPA |
| 22* | O-Ring (Inferiore pignone) | O-Ring (Pinion bottom) | NBR 70 | NBR 70 |
| 23* | O-Ring (vite regolazione) | O-Ring (Adjusting bolt) | NBR 70 | NBR 70 |
| 24 | Rondella (Regolazione) | Washer (Adjusting) | Acciaio Inox / S.S. | Stainless Steel |
| 25 | Dado (Regolazione) | Nut (Adjusting) | Acciaio Inox / S.S. | Stainless Steel |
| 26 | Vite regolazione | Adjusting bolt | Acciaio Inox / S.S. | Stainless Steel |
| 27 | Molle | Spring | 60 Si 2MnA | 60 Si 2MnA |
| 28 | Fissaggio molla | Spring cartridge | PP GF 30 | PP GF 30 |
| 29 | Bullone | Bolt | Acciaio Inox / S.S. | Stainless Steel |
| 30 | Rondella | Washer | Acciaio Inox / S.S. | Stainless Steel |
| 31 | Rondella | Washer | Acciaio Inox / S.S. | Stainless Steel |
| 32* | Tappo culatta | End cap | NBR 70 | NBR 70 |

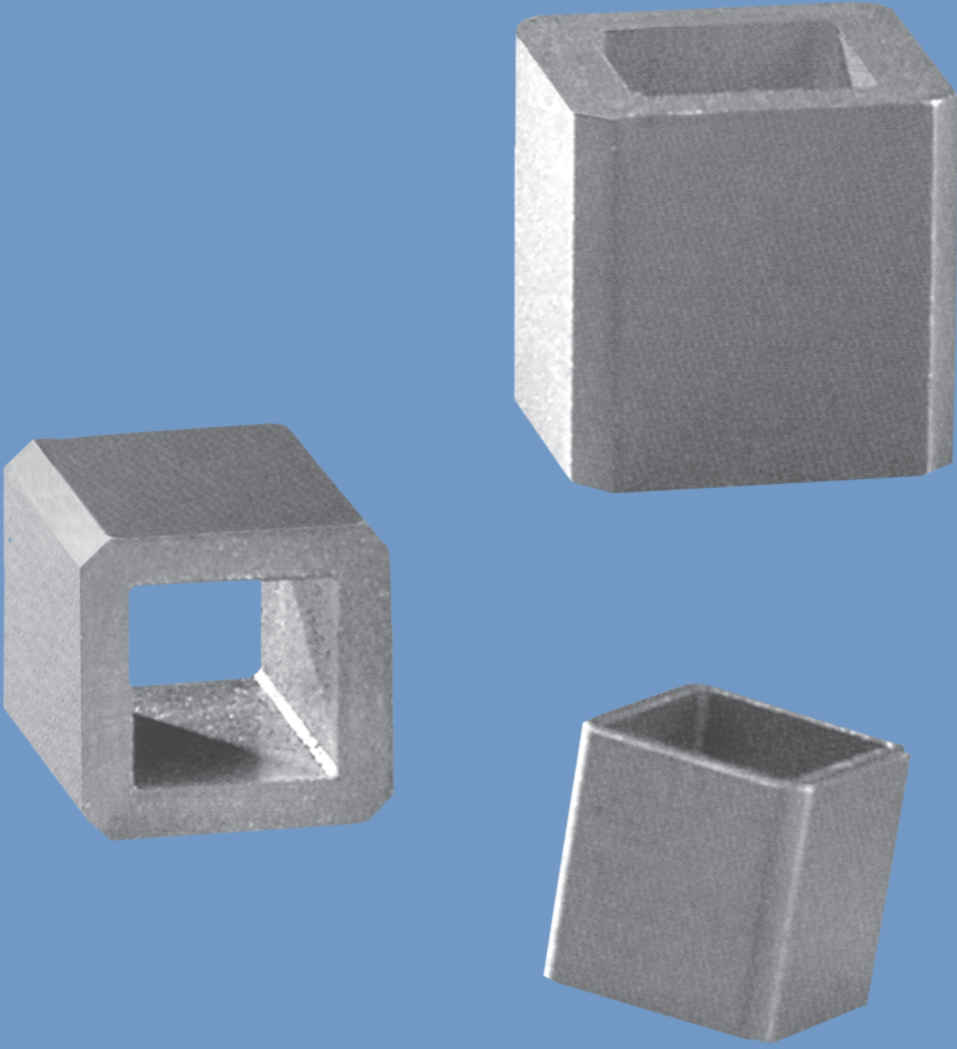

REDUCTION FOR ACTUATORS

RIDUZIONI PER ATTUATORI - REDUCTION FOR ACTUATORS

| Q/Q | | | | | | | |
|---------|------------------|------------------|------------------|------------------|------------------|--------------------------------|---------------------------------|
| COD | A | B | C | D | L | VAPORIZZATE VAPORIZE (V) | AISI 316 L AISI 316 L (X) |
| Q/Q | + 0,12 + 0,04 | - 0,04 - 0,12 | + 0,20 + 0,10 | - 0,10 - 0,20 | + 0,10 - 0,10 | | |
| 8/11 | 8 | 11 | 10,9 | 14,2 | 11 | 1 | 1 |
| 8/14 | 8 | 14 | 10,9 | 18 | 11 | 1 | 1 |
| 9/11-A | 9 | 11 | 12,2 | 14 | 11 | 1 | 1 |
| 9/11-B | 9 | 11 | 12,3 | 14 | 12 | 1 | 1 |
| 9/14 -A | 9 | 14 | 12,3 | 18 | 14 | 1 | 1 |
| 9/14-B | 9 | 14 | 12,3 | 18 | 16 | 1 | 1 |
| 9/17-A | 9 | 17 | 12,3 | 22 | 17 | 1 | 1 |
| 9/17-B | 9 | 17 | 12,3 | 22 | 22 | 1 | 1 |
| 10/14-A | 10 | 14 | 13,3 | 18 | 14 | 1 | 1 |
| 10/14-B | 10 | 14 | 13,3 | 18 | 16 | 1 | 1 |
| 10/17 | 10 | 17 | 13,3 | 22 | 17 | 1 | 1 |
| 11/14-A | 11 | 14 | 14,3 | 18 | 14 | 1 | 1 |
| 11/14-B | 11 | 14 | 14,3 | 18 | 16 | 1 | 1 |
| 11/17 | 11 | 17 | 14,3 | 22 | 17 | 1 | 1 |
| 11/22 | 11 | 22 | 14,3 | 28 | 22 | 1 | 1 |
| 12/14-A | 12 | 14 | 16,3 | 18 | 14 | 1 | 1 |
| 12/14-B | 12 | 14 | 16,3 | 18 | 16 | 1 | 1 |
| 12/17 | 12 | 17 | 16,3 | 22 | 17 | 1 | 1 |
| 14/17 | 14 | 17 | 18,3 | 22 | 17 | 1 | 1 |
| 14/22 | 14 | 22 | 18,3 | 28 | 22 | 1 | 1 |
| 14/27 | 14 | 27 | 18,3 | 36 | 27 | 1 | 1 |
| 16/22 | 16 | 22 | 21,3 | 28 | 22 | 1 | 1 |
| 17/22 | 17 | 22 | 22,3 | 28 | 22 | 1 | 1 |
| 17/27 | 17 | 27 | 22,2 | 36 | 27 | 1 | 1 |
| 18/22 | 18 | 22 | 23,3 | 28 | 22 | 1 | 1 |
| 19/27 | 19 | 27 | 25,3 | 36 | 27 | 1 | 1 |
| 19/36 | 19 | 36 | 25,3 | 45 | 36 | 1 | 1 |
| 22/27 | 22 | 27 | 28,5 | 36 | 27 | 1 | 1 |
| 22/36 | 22 | 36 | 28,5 | 45 | 36 | 1 | 1 |
| 24/27 | 24 | 27 | 25,3 | 36 | 27 | 1 | 1 |
| 27/36 | 27 | 36 | 36,3 | 45 | 36 | 1 | 1 |
| 27/46 | 27 | 46 | 36,3 | 60 | 46 | 1 | 1 |
| 30/36 | 30 | 36 | 39,2 | 45 | 36 | 1 | 1 |

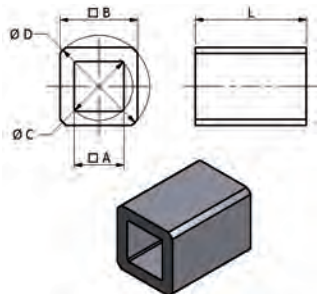

| Q/R | | | | | | | |
|-------|------------------|------------------|------------------|------------------|------------------|--------------------------------|---------------------------------|
| COD | A | B | C | D | L | VAPORIZZATE VAPORIZE (V) | AISI 316 L AISI 316 L (X) |
| Q/R | + 0,12 + 0,04 | - 0,04 - 0,12 | + 0,20 + 0,10 | - 0,10 - 0,20 | + 0,10 - 0,10 | | |
| 8/14 | 8 | 14 | 12 | 18 | 16 | 1 | 1 |
| 10/17 | 10 | 17 | 16 | 22 | 17 | 1 | 1 |

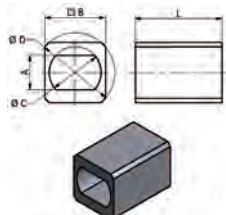

| R/R | | | | | | | |
|--------|------------------|------------------|------------------|------------------|------------------|--------------------------------|---------------------------------|
| COD | A | B | C | D | L | VAPORIZZATE VAPORIZE (V) | AISI 316 L AISI 316 L (X) |
| R/R | + 0,12 + 0,04 | - 0,04 - 0,12 | + 0,20 + 0,10 | - 0,10 - 0,20 | + 0,10 - 0,10 | | |
| 5/8 | 5 | 8 | 9 | 12 | 10 | 1 | 1 |
| 6,35/8 | 6,35 | 8 | 9 | 12 | 10 | 1 | 1 |
| 7/8 | 7 | 8 | 9 | 12 | 10 | 1 | 1 |
| 7/10 | 7 | 10 | 12 | 16 | 13 | 1 | 1 |
| 8/10 | 8 | 10 | 12 | 16 | 13 | 1 | 1 |
| 10/14 | 10 | 14 | 16 | 20 | 20 | 1 | 1 |
| 14/20 | 14 | 20 | 22 | 30 | 20 | 1 | 1 |
| 16/20 | 16 | 20 | 25 | 30 | 20 | 1 | 1 |
| 20/28 | 20 | 28 | 30 | 42 | 27 | 1 | 1 |
| 28/32 | 28 | 32 | 42 | 48 | 32 | 1 | 1 |

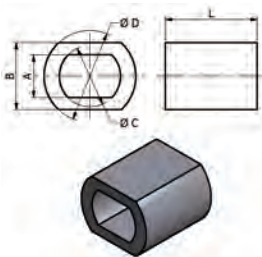

SCONTO PER QUANTITÀ: VEDI TABELLA SEGUENTE - DISCOUNT QUANTITY: SEE THE FOLLOWING LIST

| | | | | | | | | |
|---------------------|-------|---------|---------|-----------|-----------|-------------|-------------|-------------|
| QUANTITÀ - QUANTITY | 1 - 9 | 10 - 49 | 50 - 99 | 100 - 499 | 500 - 999 | 1000 - 1999 | 2000 - 2999 | 3000 - 5000 |
| SCONTO - DISCOUNT | - | 10 % | 20 % | 30 % | 40 % | 50 % | 60 % | 70 % |

| | | P/Q | | | | | VAPORIZZATE VAPORIZE (V) | AISI 316 L AISI 316 L (X) |
|--------|--|--------|--------|--------|--------|--------|--------------------------------|---------------------------------|
| COD | | A | B | C | D | L | | |
| P/Q | | + 0,12 | - 0,04 | + 0,20 | - 0,10 | + 0,10 | 🛒 | 🛒 |
| | | + 0,04 | - 0,12 | + 0,10 | - 0,20 | - 0,10 | | |
| 8/11 | | 8 | 11 | 11 | 14 | 10 | 1 | 1 |
| 9/11-A | | 9 | 11 | 12,3 | 14 | 11 | 1 | 1 |
| 9/11-B | | 9 | 11 | 12,3 | 14 | 12 | 1 | 1 |
| 9/13 | | 9 | 13 | 12,3 | 17 | 12 | 1 | 1 |
| 9/14 | | 9 | 14 | 12,3 | 18 | 16 | 1 | 1 |
| 10/14 | | 10 | 14 | 13,3 | 18 | 16 | 1 | 1 |
| 10/17 | | 10 | 17 | 13,3 | 22 | 17 | 1 | 1 |
| 11/13 | | 11 | 13 | 14,3 | 17 | 16 | 1 | 1 |
| 11/14 | | 11 | 14 | 14,3 | 18 | 16 | 1 | 1 |
| 11/17 | | 11 | 17 | 14,3 | 22 | 17 | 1 | 1 |
| 12/14 | | 12 | 14 | 16,3 | 18 | 16 | 1 | 1 |
| 12/17 | | 12 | 17 | 16,3 | 22 | 17 | 1 | 1 |
| 14/17 | | 14 | 17 | 18,3 | 22 | 17 | 1 | 1 |
| 14/22 | | 14 | 22 | 18,3 | 28 | 22 | 1 | 1 |
| 16/22 | | 16 | 22 | 21,3 | 28 | 22 | 1 | 1 |
| 17/22 | | 17 | 22 | 22,3 | 28 | 22 | 1 | 1 |
| 22/27 | | 22 | 27 | 28,5 | 36 | 27 | 1 | 1 |
| 27/36 | | 27 | 36 | 36,1 | 48 | 36 | 1 | 1 |
| 36/46 | | 36 | 46 | 46,0 | 59 | 45 | 1 | 1 |
| 46/55 | | 46 | 54,9 | 62 | 72 | 55 | 1 | 1 |
| 55/75 | | 55,1 | 74,9 | 74 | 98 | 77 | 1 | 1 |

| | | P/R | | | | | VAPORIZZATE VAPORIZE (V) | AISI 316 L AISI 316 L (X) |
|-------|--|--------|--------|--------|--------|--------|--------------------------------|---------------------------------|
| COD | | A | B | C | D | L | | |
| P/R | | + 0,12 | - 0,04 | + 0,20 | - 0,10 | + 0,10 | 🛒 | 🛒 |
| | | + 0,04 | - 0,12 | + 0,10 | - 0,20 | - 0,10 | | |
| 8/13 | | 8 | 13 | 12 | 17 | 12 | 1 | 1 |
| 8/14 | | 8 | 14 | 12 | 18 | 14 | 1 | 1 |
| 9/14 | | 9 | 14 | 12,2 | 18 | 14 | 1 | 1 |
| 11/22 | | 11 | 22 | 16,2 | 28 | 22 | 1 | 1 |
| 14/22 | | 14 | 22 | 20,2 | 28 | 22 | 1 | 1 |
| 18/27 | | 18 | 27 | 25 | 36 | 27 | 1 | 1 |
| 22/36 | | 22 | 36 | 30 | 48 | 36 | 1 | 1 |

| | | P/P | | | | | VAPORIZZATE VAPORIZE (V) | AISI 316 L AISI 316 L (X) |
|-------|--|--------|--------|--------|--------|--------|--------------------------------|---------------------------------|
| COD | | A | B | C | D | L | | |
| P/P | | + 0,12 | - 0,04 | + 0,20 | - 0,10 | + 0,10 | 🛒 | 🛒 |
| | | + 0,04 | - 0,12 | + 0,10 | - 0,20 | - 0,10 | | |
| 14/22 | | 14 | 22 | 18,2 | 28 | 12 | 1 | 1 |
| 17/22 | | 17 | 22 | 22,2 | 28 | 20 | 1 | 1 |

VAPORIZZAZIONE: BRUNITURA ESEGUITA CON VAPORE DI H₂O AD ALTA TEMPERATURA
STEAMING: BURNISHING PERFORMED WITH H₂O STEAM AT HIGH TEMPERATURE

🛒 SCONTO PER QUANTITÀ: VEDI TABELLA SEGUENTE - DISCOUNT QUANTITY: SEE THE FOLLOWING LIST

| QUANTITÀ - QUANTITY | 1 - 9 | 10 - 49 | 50 - 99 | 100 - 499 | 500 - 999 | 1000 - 1999 | 2000 - 2999 | 3000 - 5000 |
|---------------------|-------|---------|---------|-----------|-----------|-------------|-------------|-------------|
| SCONTO - DISCOUNT | - | 10 % | 20 % | 30 % | 40 % | 50 % | 60 % | 70 % |

FILTRI SINTERIZZATI BRONZO - INOX - SINTERED BRONZE / STAINLESS STEEL FILTERS

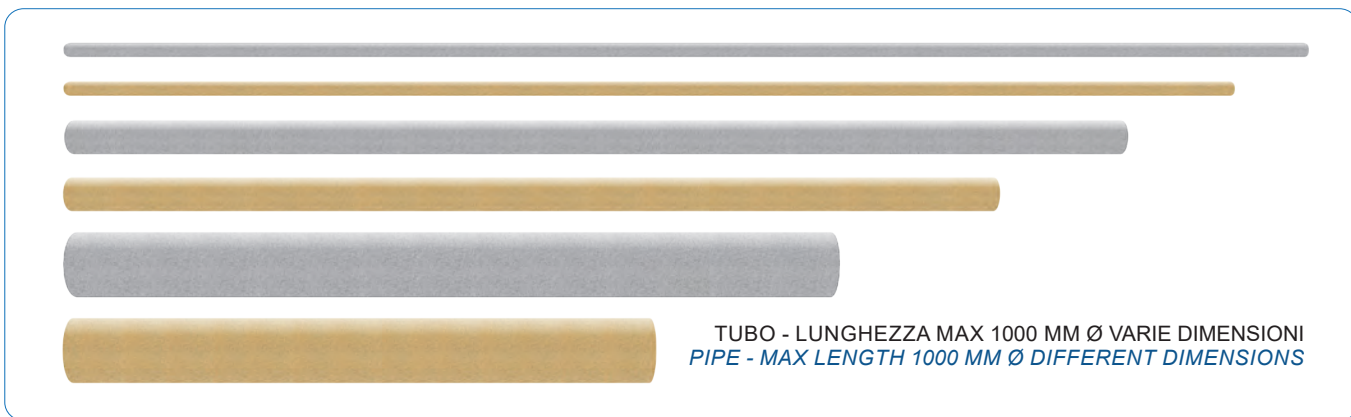
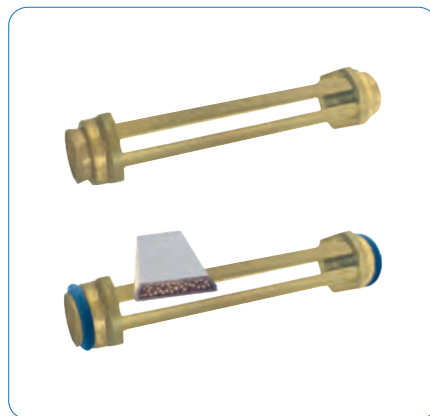
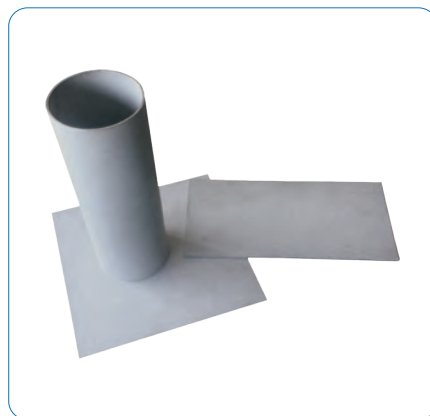
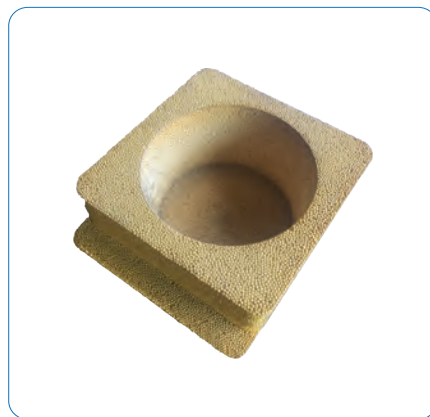



VALVES

| | | | | | |
|---|--------------|-----|--|-----------------------|-----|
|  | VS-FF-A-I | 178 |  | VSX-MF | 179 |
|  | VS-FF-M-I | 178 |  | VSX-C | 179 |
|  | VS-MF-B-A-I | 178 |  | VSX-3VC | 179 |
|  | VS-MF-B-M-I | 178 |  | VFX | 179 |
|  | VS-3FR-L-A-I | 178 |  | VFX-MF | 179 |
|  | VS-3FR-L-M-I | 178 |  | VFX-C | 179 |
|  | VS-3P-A-I | 178 |  | STAFFA BRACKET | 179 |
|  | VS-3P-M-I | 178 |  | PROLUNGA EXTENSION | 179 |
|  | VSX-3P | 178 |  | GSX-C | 179 |
|  | VSX-3P-M | 178 |  | GSX | 179 |
|  | VSX-3PC | 178 |  | VSX-M | 180 |
|  | VSX-3PC-M | 178 |  | VSX-MF-M | 180 |
|  | VSX | 179 |  | VSX-C-M | 180 |

| | | | | | |
|---|-----------|-----|---|-------------|-----|
|  | VSX-3VC-M | 180 |  | VS-3FT-L | 181 |
|  | VFX-M | 180 |  | VS-3FT-T | 181 |
|  | VFX-MF-M | 180 |  | VS-6F-L | 181 |
|  | VFX-C-M | 180 |  | VS-FF-M | 182 |
|  | MX-S | 180 |  | VS-FF-L-M | 182 |
|  | MX | 180 |  | VS-MF-B-M | 182 |
|  | VS-FF | 181 |  | VSD-3FR-L-M | 182 |
|  | VS-FF-L | 181 |  | VSD-3FR-T-M | 182 |
|  | VS-MF-B | 181 |  | VS-3FR-L-M | 182 |
|  | VSD-3FR-L | 181 |  | VS-3FR-T-M | 182 |
|  | VSD-3FR-T | 181 |  | VS-3FT-L-M | 182 |
|  | VS-3FR-L | 181 |  | VS-3FT-T-M | 182 |
|  | VS-3FR-T | 181 |  | VS-P | 183 |

VALVOLE INDUSTRIAL IN OTTONE ED INOX - BRASS / STAINLESS STEEL INDUSTRIAL VALVES

VS-FF-A-I



Ottone non nichelato
Not nickel-plated brass

| COD | NORMA DIN DIN STD | DIMENSIONI SIZES | ☒ |
|--------------|----------------------|---------------------|---|
| 2 VS-FF-A-I | 8 | 1/4" | 1 |
| 3 VS-FF-A-I | 10 | 3/8" | 1 |
| 4 VS-FF-A-I | 15 | 1/2" | 1 |
| 5 VS-FF-A-I | 20 | 3/4" | 1 |
| 6 VS-FF-A-I | 25 | 1" | 1 |
| 11 VS-FF-A-I | 32 | 1" 1/4 | 1 |
| 12 VS-FF-A-I | 40 | 1" 1/2 | 1 |
| 13 VS-FF-A-I | 50 | 2" | 1 |

VS-FF-M-I



Ottone non nichelato
Not nickel-plated brass

| COD | NORMA DIN DIN STD | DIMENSIONI SIZES | ☒ |
|--------------|----------------------|---------------------|---|
| 2 VS-FF-M-I | 8 | 1/4" | 1 |
| 3 VS-FF-M-I | 10 | 3/8" | 1 |
| 4 VS-FF-M-I | 15 | 1/2" | 1 |
| 5 VS-FF-M-I | 20 | 3/4" | 1 |
| 6 VS-FF-M-I | 25 | 1" | 1 |
| 11 VS-FF-M-I | 32 | 1" 1/4 | 1 |
| 12 VS-FF-M-I | 40 | 1" 1/2 | 1 |
| 13 VS-FF-M-I | 50 | 2" | 1 |

VS-MF-B-A-I



Ottone non nichelato
Not nickel-plated brass

| COD | NORMA DIN DIN STD | DIMENSIONI SIZES | ☒ |
|---------------|----------------------|---------------------|---|
| 4 VS-MF-B-A-I | 15 | 1/2" | 1 |
| 5 VS-MF-B-A-I | 20 | 3/4" | 1 |
| 6 VS-MF-B-A-I | 25 | 1" | 1 |

VS-MF-B-M-I



Ottone non nichelato
Not nickel-plated brass

| COD | NORMA DIN DIN STD | DIMENSIONI SIZES | ☒ |
|---------------|----------------------|---------------------|---|
| 4 VS-MF-B-M-I | 15 | 1/2" | 1 |
| 5 VS-MF-B-M-I | 20 | 3/4" | 1 |
| 6 VS-MF-B-M-I | 25 | 1" | 1 |

VS-3FR-L-A-I



Ottone non nichelato
Not nickel-plated brass

| COD | NORMA DIN DIN STD | DIMENSIONI SIZES | ☒ |
|-----------------|----------------------|---------------------|---|
| 2 VS-3FR-L-A-I | | | 1 |
| 3 VS-3FR-L-A-I | | | 1 |
| 4 VS-3FR-L-A-I | 15 | 1/2" | 1 |
| 5 VS-3FR-L-A-I | 20 | 3/4" | 1 |
| 6 VS-3FR-L-A-I | 25 | 1" | 1 |
| 11 VS-3FR-L-A-I | 32 | 1" 1/4 | 1 |
| 12 VS-3FR-L-A-I | 40 | 1" 1/2 | 1 |
| 13 VS-3FR-L-A-I | 50 | 2" | 1 |

VS-3FR-L-M-I



Ottone non nichelato
Not nickel-plated brass

| COD | NORMA DIN DIN STD | DIMENSIONI SIZES | ☒ |
|-----------------|----------------------|---------------------|---|
| 2 VS-3FR-L-M-I | | | 1 |
| 3 VS-3FR-L-M-I | | | 1 |
| 4 VS-3FR-L-M-I | 15 | 1/2" | 1 |
| 5 VS-3FR-L-M-I | 20 | 3/4" | 1 |
| 6 VS-3FR-L-M-I | 25 | 1" | 1 |
| 11 VS-3FR-L-M-I | 32 | 1" 1/4 | 1 |
| 12 VS-3FR-L-M-I | 40 | 1" 1/2 | 1 |
| 13 VS-3FR-L-M-I | 50 | 2" | 1 |

VS-3P-A-I



Ottone non nichelato
Not nickel-plated brass

| COD | NORMA DIN DIN STD | DIMENSIONI SIZES | ☒ |
|-------------|----------------------|---------------------|---|
| 1 VS-3P-A-I | 15 | 1/2" | 1 |
| 2 VS-3P-A-I | 20 | 3/4" | 1 |
| 3 VS-3P-A-I | 25 | 1" | 1 |
| 4 VS-3P-A-I | 32 | 1" 1/4 | 1 |
| 5 VS-3P-A-I | 40 | 1" 1/2 | 1 |
| 6 VS-3P-A-I | 50 | 2" | 1 |
| 7 VS-3P-A-I | 65 | 2" 1/2 | 1 |
| 8 VS-3P-A-I | 80 | 3" | 1 |

VS-3P-M-I



Ottone non nichelato
Not nickel-plated brass

| COD | NORMA DIN DIN STD | DIMENSIONI SIZES | ☒ |
|-------------|----------------------|---------------------|---|
| 1 VS-3P-M-I | 15 | 1/2" | 1 |
| 2 VS-3P-M-I | 20 | 3/4" | 1 |
| 3 VS-3P-M-I | 25 | 1" | 1 |
| 4 VS-3P-M-I | 32 | 1" 1/4 | 1 |
| 5 VS-3P-M-I | 40 | 1" 1/2 | 1 |
| 6 VS-3P-M-I | 50 | 2" | 1 |
| 7 VS-3P-M-I | 65 | 2" 1/2 | 1 |
| 8 VS-3P-M-I | 80 | 3" | 1 |

VSX-3P



AISI 316 - AISI 316

| COD | NORMA DIN DIN STD | DIMENSIONI SIZES | ☒ |
|----------|----------------------|---------------------|---|
| 1 VSX-3P | 15 | 1/2" | 1 |
| 2 VSX-3P | 20 | 3/4" | 1 |
| 3 VSX-3P | 25 | 1" | 1 |
| 4 VSX-3P | 32 | 1" 1/4 | 1 |
| 5 VSX-3P | 40 | 1" 1/2 | 1 |
| 6 VSX-3P | 50 | 2" | 1 |
| 7 VSX-3P | 65 | 2" 1/2 | 1 |
| 8 VSX-3P | 80 | 3" | 1 |

VSX-3P-M



AISI 316 - AISI 316

| COD | NORMA DIN DIN STD | DIMENSIONI SIZES | ☒ |
|------------|----------------------|---------------------|---|
| 1 VSX-3P-M | 15 | 1/2" | 1 |
| 2 VSX-3P-M | 20 | 3/4" | 1 |
| 3 VSX-3P-M | 25 | 1" | 1 |
| 4 VSX-3P-M | 32 | 1" 1/4 | 1 |
| 5 VSX-3P-M | 40 | 1" 1/2 | 1 |
| 6 VSX-3P-M | 50 | 2" | 1 |
| 7 VSX-3P-M | 65 | 2" 1/2 | 1 |
| 8 VSX-3P-M | 80 | 3" | 1 |

VSX-3PC



AISI 316 - AISI 316
CLAMP - CLAMP

| COD | NORMA DIN DIN STD | DIMENSIONI SIZES | ☒ |
|-----------|----------------------|---------------------|---|
| 1 VSX-3PC | 15 | 1/2" | 1 |
| 2 VSX-3PC | 20 | 3/4" | 1 |
| 3 VSX-3PC | 25 | 1" | 1 |
| 4 VSX-3PC | 32 | 1" 1/4 | 1 |
| 5 VSX-3PC | 40 | 1" 1/2 | 1 |
| 6 VSX-3PC | 50 | 2" | 1 |
| 7 VSX-3PC | 65 | 2" 1/2 | 1 |
| 8 VSX-3PC | 80 | 3" | 1 |

VSX-3PC-M



AISI 316 - AISI 316
CLAMP - CLAMP

| COD | NORMA DIN DIN STD | DIMENSIONI SIZES | ☒ |
|-------------|----------------------|---------------------|---|
| 1 VSX-3PC-C | 15 | 1/2" | 1 |
| 2 VSX-3PC-C | 20 | 3/4" | 1 |
| 3 VSX-3PC-C | 25 | 1" | 1 |
| 4 VSX-3PC-C | 32 | 1" 1/4 | 1 |
| 5 VSX-3PC-C | 40 | 1" 1/2 | 1 |
| 6 VSX-3PC-C | 50 | 2" | 1 |
| 7 VSX-3PC-C | 65 | 2" 1/2 | 1 |
| 8 VSX-3PC-C | 80 | 3" | 1 |

VALVOLE A SFERA - *BALL VALVES*

VSX



| COD | NORMA DIN <i>DIN STD</i> | DIMENSIONI <i>SIZES</i> | 🛒 |
|-------|-----------------------------|----------------------------|---|
| 1 VSX | 15 | 1/2" | 1 |
| 2 VSX | 20 | 3/4" | 1 |
| 3 VSX | 25 | 1" | 1 |
| 4 VSX | 32 | 1" 1/4 | 1 |
| 5 VSX | 40 | 1" 1/2 | 1 |
| 6 VSX | 50 | 2" | 1 |
| 7 VSX | 65 | 2" 1/2 | 1 |
| 8 VSX | 80 | 3" | 1 |

AISI 316 - AISI 316

VSX-MF



| COD | NORMA DIN <i>DIN STD</i> | DIMENSIONI <i>SIZES</i> | 🛒 |
|----------|-----------------------------|----------------------------|---|
| 1 VSX-MF | 15 | 1/2" | 1 |
| 2 VSX-MF | 20 | 3/4" | 1 |
| 3 VSX-MF | 25 | 1" | 1 |
| 4 VSX-MF | 32 | 1" 1/4 | 1 |
| 5 VSX-MF | 40 | 1" 1/2 | 1 |
| 6 VSX-MF | 50 | 2" | 1 |
| 7 VSX-MF | 65 | 2" 1/2 | 1 |
| 8 VSX-MF | 80 | 3" | 1 |

AISI 316 - AISI 316

VSX-C



| COD | NORMA DIN <i>DIN STD</i> | DIMENSIONI <i>SIZES</i> | 🛒 |
|---------|-----------------------------|----------------------------|---|
| 1 VSX-C | 15 | 1/2" | 1 |
| 2 VSX-C | 20 | 3/4" | 1 |
| 3 VSX-C | 25 | 1" | 1 |
| 4 VSX-C | 32 | 1" 1/4 | 1 |
| 5 VSX-C | 40 | 1" 1/2 | 1 |
| 6 VSX-C | 50 | 2" | 1 |
| 7 VSX-C | 65 | 2" 1/2 | 1 |
| 8 VSX-C | 80 | 3" | 1 |

AISI 316 - AISI 316
CLAMP - CLAMP

VSX-3VC



| COD | NORMA DIN <i>DIN STD</i> | DIMENSIONI <i>SIZES</i> | 🛒 |
|-----------|-----------------------------|----------------------------|---|
| 1 VSX-3VC | 15 | 1/2" | 1 |
| 2 VSX-3VC | 20 | 3/4" | 1 |
| 3 VSX-3VC | 25 | 1" | 1 |
| 4 VSX-3VC | 32 | 1" 1/4 | 1 |
| 5 VSX-3VC | 40 | 1" 1/2 | 1 |
| 6 VSX-3VC | 50 | 2" | 1 |
| 7 VSX-3VC | 65 | 2" 1/2 | 1 |
| 8 VSX-3VC | 80 | 3" | 1 |

AISI 316 - AISI 316
3 VIE - CLAMP
3 WAYS - CLAMP

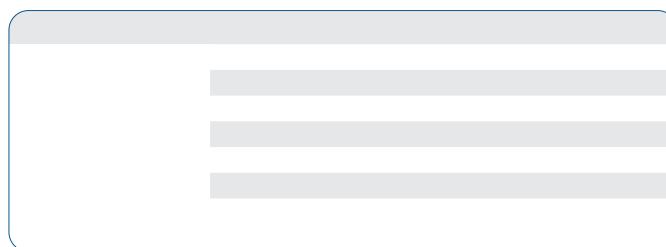
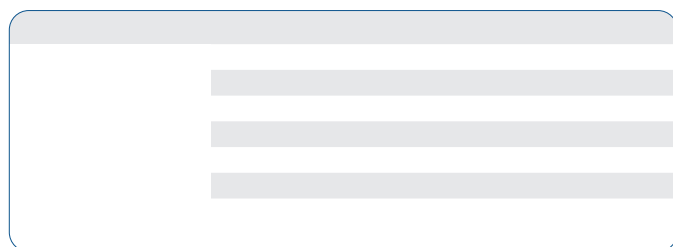

VALVOLE A FARFALLA - *BUTTERFLY VALVES*

VFX



| COD | NORMA DIN <i>DIN STD</i> | DIMENSIONI <i>SIZES</i> | 🛒 |
|-------|-----------------------------|----------------------------|---|
| 1 VFX | 15 | 1/2" | 1 |
| 2 VFX | 20 | 3/4" | 1 |
| 3 VFX | 25 | 1" | 1 |
| 4 VFX | 32 | 1" 1/4 | 1 |
| 5 VFX | 40 | 1" 1/2 | 1 |
| 6 VFX | 50 | 2" | 1 |
| 7 VFX | 65 | 2" 1/2 | 1 |
| 8 VFX | 80 | 3" | 1 |

AISI 316 - AISI 316

VFX-MF



| COD | NORMA DIN <i>DIN STD</i> | DIMENSIONI <i>SIZES</i> | 🛒 |
|----------|-----------------------------|----------------------------|---|
| 1 VFX-MF | 15 | 1/2" | 1 |
| 2 VFX-MF | 20 | 3/4" | 1 |
| 3 VFX-MF | 25 | 1" | 1 |
| 4 VFX-MF | 32 | 1" 1/4 | 1 |
| 5 VFX-MF | 40 | 1" 1/2 | 1 |
| 6 VFX-MF | 50 | 2" | 1 |
| 7 VFX-MF | 65 | 2" 1/2 | 1 |
| 8 VFX-MF | 80 | 3" | 1 |

AISI 316 - AISI 316

VFX-C



| COD | NORMA DIN <i>DIN STD</i> | DIMENSIONI <i>SIZES</i> | 🛒 |
|---------|-----------------------------|----------------------------|---|
| 1 VFX-C | 15 | 1/2" | 1 |
| 2 VFX-C | 20 | 3/4" | 1 |
| 3 VFX-C | 25 | 1" | 1 |
| 4 VFX-C | 32 | 1" 1/4 | 1 |
| 5 VFX-C | 40 | 1" 1/2 | 1 |
| 6 VFX-C | 50 | 2" | 1 |
| 7 VFX-C | 65 | 2" 1/2 | 1 |
| 8 VFX-C | 80 | 3" | 1 |

AISI 316 - AISI 316
CLAMP - CLAMP



Staffa - Bracket *Prolunga - Extension*

A richiesta da 1/2" a 3" - *Available from 1/2" to 3"*

GSX-C



| COD | NORMA DIN <i>DIN STD</i> | DIMENSIONI <i>SIZES</i> | 🛒 |
|---------|-----------------------------|----------------------------|---|
| 1 GSX-C | 15 | 1/2" | 1 |
| 2 GSX-C | 20 | 3/4" | 1 |
| 3 GSX-C | 25 | 1" | 1 |
| 4 GSX-C | 32 | 1" 1/4 | 1 |
| 5 GSX-C | 40 | 1" 1/2 | 1 |
| 6 GSX-C | 50 | 2" | 1 |
| 7 GSX-C | 65 | 2" 1/2 | 1 |
| 8 GSX-C | 80 | 3" | 1 |

AISI 316 - AISI 316
CLAMP - CLAMP

GSX



| COD | NORMA DIN <i>DIN STD</i> | DIMENSIONI <i>SIZES</i> | 🛒 |
|-------|-----------------------------|----------------------------|---|
| 1 GSX | 15 | 1/2" | 1 |
| 2 GSX | 20 | 3/4" | 1 |
| 3 GSX | 25 | 1" | 1 |
| 4 GSX | 32 | 1" 1/4 | 1 |
| 5 GSX | 40 | 1" 1/2 | 1 |
| 6 GSX | 50 | 2" | 1 |
| 7 VSX | 65 | 2" 1/2 | 1 |
| 8 GSX | 80 | 3" | 1 |

AISI 316 - AISI 316

VALVOLE MANUALI AISI 316 SERIE SANITARY - *SANITARY SERIES AISI 316 MANUAL VALVES*

VALVOLE A SFERA / *BALL VALVES*

VSX-M



| COD | NORMA DIN DIN STD | DIMENSIONI SIZES | 🛒 |
|---------|----------------------|---------------------|---|
| 1 VSX-M | 15 | 1/2" | 1 |
| 2 VSX-M | 20 | 3/4" | 1 |
| 3 VSX-M | 25 | 1" | 1 |
| 4 VSX-M | 32 | 1" 1/4 | 1 |
| 5 VSX-M | 40 | 1" 1/2 | 1 |
| 6 VSX-M | 50 | 2" | 1 |
| 7 VSX-M | 65 | 2" 1/2 | 1 |
| 8 VSX-M | 80 | 3" | 1 |

AISI 316 - AISI 316

VSX-MF-M



| COD | NORMA DIN DIN STD | DIMENSIONI SIZES | 🛒 |
|----------|----------------------|---------------------|---|
| 1 VSX-MF | 15 | 1/2" | 1 |
| 2 VSX-MF | 20 | 3/4" | 1 |
| 3 VSX-MF | 25 | 1" | 1 |
| 4 VSX-MF | 32 | 1" 1/4 | 1 |
| 5 VSX-MF | 40 | 1" 1/2 | 1 |
| 6 VSX-MF | 50 | 2" | 1 |
| 7 VSX-MF | 65 | 2" 1/2 | 1 |
| 8 VSX-MF | 80 | 3" | 1 |

AISI 316 - AISI 316

VSX-C-M



| COD | NORMA DIN DIN STD | DIMENSIONI SIZES | 🛒 |
|-----------|----------------------|---------------------|---|
| 1 VSX-C-M | 15 | 1/2" | 1 |
| 2 VSX-C-M | 20 | 3/4" | 1 |
| 3 VSX-C-M | 25 | 1" | 1 |
| 4 VSX-C-M | 32 | 1" 1/4 | 1 |
| 5 VSX-C-M | 40 | 1" 1/2 | 1 |
| 6 VSX-C-M | 50 | 2" | 1 |
| 7 VSX-C-M | 65 | 2" 1/2 | 1 |
| 8 VSX-C-M | 80 | 3" | 1 |

AISI 316 - AISI 316
CLAMP - CLAMP

VSX-3VC-M



| COD | NORMA DIN DIN STD | DIMENSIONI SIZES | 🛒 |
|-------------|----------------------|---------------------|---|
| 1 VSX-3VC-M | 15 | 1/2" | 1 |
| 2 VSX-3VC-M | 20 | 3/4" | 1 |
| 3 VSX-3VC-M | 25 | 1" | 1 |
| 4 VSX-3VC-M | 32 | 1" 1/4 | 1 |
| 5 VSX-3VC-M | 40 | 1" 1/2 | 1 |
| 6 VSX-3VC-M | 50 | 2" | 1 |
| 7 VSX-3VC-M | 65 | 2" 1/2 | 1 |
| 8 VSX-3VC-M | 80 | 3" | 1 |

AISI 316 - AISI 316
3 VIE - CLAMP
3 WAYS - CLAMP

VALVOLE A FARFALLA - *BUTTERFLY VALVES*

VFX-M



| COD | NORMA DIN DIN STD | DIMENSIONI SIZES | 🛒 |
|---------|----------------------|---------------------|---|
| 1 VFX-M | 15 | 1/2" | 1 |
| 2 VFX-M | 20 | 3/4" | 1 |
| 3 VFX-M | 25 | 1" | 1 |
| 4 VFX-M | 32 | 1" 1/4 | 1 |
| 5 VFX-M | 40 | 1" 1/2 | 1 |
| 6 VFX-M | 50 | 2" | 1 |
| 7 VFX-M | 65 | 2" 1/2 | 1 |
| 8 VFX-M | 80 | 3" | 1 |

AISI 316 - AISI 316

VFX-MF-M



| COD | NORMA DIN DIN STD | DIMENSIONI SIZES | 🛒 |
|------------|----------------------|---------------------|---|
| 1 VFX-MF-M | 15 | 1/2" | 1 |
| 2 VFX-MF-M | 20 | 3/4" | 1 |
| 3 VFX-MF-M | 25 | 1" | 1 |
| 4 VFX-MF-M | 32 | 1" 1/4 | 1 |
| 5 VFX-MF-M | 40 | 1" 1/2 | 1 |
| 6 VFX-MF-M | 50 | 2" | 1 |
| 7 VFX-MF-M | 65 | 2" 1/2 | 1 |
| 8 VFX-MF-M | 80 | 3" | 1 |

AISI 316 - AISI 316

VFX-C-M



| COD | NORMA DIN DIN STD | DIMENSIONI SIZES | 🛒 |
|-----------|----------------------|---------------------|---|
| 1 VFX-C-M | 15 | 1/2" | 1 |
| 2 VFX-C-M | 20 | 3/4" | 1 |
| 3 VFX-C-M | 25 | 1" | 1 |
| 4 VFX-C-M | 32 | 1" 1/4 | 1 |
| 5 VFX-C-M | 40 | 1" 1/2 | 1 |
| 6 VFX-C-M | 50 | 2" | 1 |
| 7 VFX-C-M | 65 | 2" 1/2 | 1 |
| 8 VFX-C-M | 80 | 3" | 1 |

AISI 316 - AISI 316
CLAMP - CLAMP

MX-S



| COD | NORMA DIN DIN STD | DIMENSIONI SIZES | 🛒 |
|--------|----------------------|---------------------|---|
| 2 MX-S | 25 ÷ 65 | 1" - 2" 1/2 | 1 |
| 3 MX-S | 80 ÷ 100 | 3" - 4" | 1 |

AISI 316

MX



| COD | NORMA DIN DIN STD | DIMENSIONI SIZES | 🛒 |
|------|----------------------|---------------------|---|
| 1 MX | 15 ÷ 20 | 1/2" - 3/4" | 1 |
| 2 MX | 25 ÷ 65 | 1" - 2" 1/2 | 1 |
| 3 MX | 80 ÷ 100 | 3" - 4" | 1 |

AISI 316

I PREZZI DELLE VALVOLE A FARFALLA VFX-M / VFX-MF / VFX-C-M SI INTENDONO NON COMPRESIVI DI LEVA.
BUTTERFLY VALVES VFX-M / VFX-MF / VFX-C-M PRICES: LEVER NOT INCLUDED.

VS-FF



| COD | NORMA DIN <i>DIN STD</i> | DIMENSIONI <i>SIZES</i> | 🛒 |
|----------|-----------------------------|----------------------------|---|
| 2 VS-FF | 8 | 1/4" | 1 |
| 3 VS-FF | 10 | 3/8" | 1 |
| 4 VS-FF | 15 | 1/2" | 1 |
| 5 VS-FF | 20 | 3/4" | 1 |
| 6 VS-FF | 25 | 1" | 1 |
| 11 VS-FF | 32 | 1"-1/4 | 1 |
| 12 VS-FF | 40 | 1"-1/2 | 1 |
| 13 VS-FF | 50 | 2" | 1 |

VS-FF-L



| COD | NORMA DIN <i>DIN STD</i> | DIMENSIONI <i>SIZES</i> | 🛒 |
|------------|-----------------------------|----------------------------|---|
| 4 VS-FF-L | 10 | 1/2" | 1 |
| 5 VS-FF-L | 20 | 3/4" | 1 |
| 6 VS-FF-L | 25 | 1" | 1 |
| 11 VS-FF-L | 32 | 1"-1/4 | 1 |
| 12 VS-FF-L | 40 | 1"-1/2 | 1 |
| 13 VS-FF-L | 50 | 2" | 1 |

VS-MF-B



| COD | NORMA DIN <i>DIN STD</i> | DIMENSIONI <i>SIZES</i> | 🛒 |
|-----------|-----------------------------|----------------------------|---|
| 4 VS-MF-B | 15 | 1/2" | 1 |
| 5 VS-MF-B | 20 | 3/4" | 1 |
| 6 VS-MF-B | 25 | 1" | 1 |

Empty table placeholder.

VSD-3FR-L



| COD | NORMA DIN <i>DIN STD</i> | DIMENSIONI <i>SIZES</i> | 🛒 |
|--------------|-----------------------------|----------------------------|---|
| 2 VSD-3FR-L | 10 | 1/4" | 1 |
| 3 VSD-3FR-L | 10 | 3/8" | 1 |
| 4 VSD-3FR-L | 15 | 1/2" | 1 |
| 5 VSD-3FR-L | 20 | 3/4" | 1 |
| 6 VSD-3FR-L | 25 | 1" | 1 |
| 11 VSD-3FR-L | 32 | 1"-1/4 | 1 |
| 12 VSD-3FR-L | 40 | 1"-1/2 | 1 |
| 13 VSD-3FR-L | 50 | 2" | 1 |

VSD-3FR-T



| COD | NORMA DIN <i>DIN STD</i> | DIMENSIONI <i>SIZES</i> | 🛒 |
|--------------|-----------------------------|----------------------------|---|
| 2 VSD-3FR-T | 10 | 1/4" | 1 |
| 3 VSD-3FR-T | 10 | 3/8" | 1 |
| 4 VSD-3FR-T | 15 | 1/2" | 1 |
| 5 VSD-3FR-T | 20 | 3/4" | 1 |
| 6 VSD-3FR-T | 25 | 1" | 1 |
| 11 VSD-3FR-T | 32 | 1"-1/4 | 1 |
| 12 VSD-3FR-T | 40 | 1"-1/2 | 1 |
| 13 VSD-3FR-T | 50 | 2" | 1 |

VS-3FR-L



| COD | NORMA DIN <i>DIN STD</i> | DIMENSIONI <i>SIZES</i> | 🛒 |
|-------------|-----------------------------|----------------------------|---|
| 2 VS-3FR-L | 10 | 1/4" | 1 |
| 3 VS-3FR-L | 10 | 3/8" | 1 |
| 4 VS-3FR-L | 15 | 1/2" | 1 |
| 5 VS-3FR-L | 20 | 3/4" | 1 |
| 6 VS-3FR-L | 25 | 1" | 1 |
| 11 VS-3FR-L | 32 | 1"-1/4 | 1 |
| 12 VS-3FR-L | 40 | 1"-1/2 | 1 |
| 13 VS-3FR-L | 50 | 2" | 1 |

VS-3FR-T



| COD | NORMA DIN <i>DIN STD</i> | DIMENSIONI <i>SIZES</i> | 🛒 |
|-------------|-----------------------------|----------------------------|---|
| 2 VS-3FR-T | 10 | 1/4" | 1 |
| 3 VS-3FR-T | 10 | 3/8" | 1 |
| 4 VS-3FR-T | 15 | 1/2" | 1 |
| 5 VS-3FR-T | 20 | 3/4" | 1 |
| 6 VS-3FR-T | 25 | 1" | 1 |
| 11 VS-3FR-T | 32 | 1"-1/4 | 1 |
| 12 VS-3FR-T | 40 | 1"-1/2 | 1 |
| 13 VS-3FR-T | 50 | 2" | 1 |

VS-3FT-L



| COD | NORMA DIN <i>DIN STD</i> | DIMENSIONI <i>SIZES</i> | 🛒 |
|-------------|-----------------------------|----------------------------|---|
| 2 VS-3FT-L | 10 | 1/4" | 1 |
| 3 VS-3FT-L | 10 | 3/8" | 1 |
| 4 VS-3FT-L | 15 | 1/2" | 1 |
| 5 VS-3FT-L | 20 | 3/4" | 1 |
| 6 VS-3FT-L | 25 | 1" | 1 |
| 11 VS-3FT-L | 32 | 1"-1/4 | 1 |
| 12 VS-3FT-L | 40 | 1"-1/2 | 1 |
| 13 VS-3FT-L | 50 | 2" | 1 |

VS-3FT-T



| COD | NORMA DIN <i>DIN STD</i> | DIMENSIONI <i>SIZES</i> | 🛒 |
|-------------|-----------------------------|----------------------------|---|
| 2 VS-3FT-T | 10 | 1/4" | 1 |
| 3 VS-3FT-T | 10 | 3/8" | 1 |
| 4 VS-3FT-T | 15 | 1/2" | 1 |
| 5 VS-3FT-T | 20 | 3/4" | 1 |
| 6 VS-3FT-T | 25 | 1" | 1 |
| 11 VS-3FT-T | 32 | 1"-1/4 | 1 |
| 12 VS-3FT-T | 40 | 1"-1/2 | 1 |
| 13 VS-3FT-T | 50 | 2" | 1 |

VS-6F-L



| COD | NORMA DIN <i>DIN STD</i> | DIMENSIONI <i>SIZES</i> | 🛒 |
|-----------|-----------------------------|----------------------------|---|
| 4 VS-6F-L | 10 | 1/2" | 1 |
| 5 VS-6F-L | 15 | 3/4" | 1 |

INFORMAZIONI TECNICHE - TECHNICAL INFORMATIONS

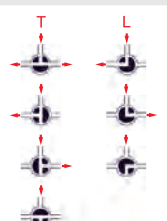

| | |
|-----------------|--------------------------------|
| TIPO 4-5-6-7 | PASSAGGIO RIDOTTO |
| TIPO 8-9 | PASSAGGIO TOTALE |
| TIPO 4-6-8-9-10 | SFERA FORATA A "L" |
| TIPO 5-7 | SFERA FORATA A "T" |
| TIPO 6-7-10 | ATTACCHI MASCHIO (A RICHIESTA) |
| 4-5-6-7 TYPE | REDUCED BORE |
| 8-9 TYPE | FULL BORE |
| 4-6-8-9-10 TYPE | "L" PORT BRASS BORE |
| 5-7 TYPE | "T" PORT BRASS BORE |
| 6-7-10 TYPE | MALE (ON REQUEST) |

TEMPERATURA DI LAVORO / OPERATING TEMPERATURE: - 10 °C / + 100 °C

VALVOLE IN OTTONE NICHELATO A SFERA MANUALI - NICKEL PLATED BRASS MANUAL BALL VALVES

VS-FF-M



| COD | NORMA DIN DIN STD | DIMENSIONI SIZES | 🛒 |
|------------|----------------------|---------------------|---|
| 2 VS-FF-M | 8 | 1/4" | 1 |
| 3 VS-FF-M | 10 | 3/8" | 1 |
| 4 VS-FF-M | 15 | 1/2" | 1 |
| 5 VS-FF-M | 20 | 3/4" | 1 |
| 6 VS-FF-M | 25 | 1" | 1 |
| 11 VS-FF-M | 32 | 1"-1/4 | 1 |
| 12 VS-FF-M | 40 | 1"-1/2 | 1 |
| 13 VS-FF-M | 50 | 2" | 1 |

VS-FF-L-M



| COD | NORMA DIN DIN STD | DIMENSIONI SIZES | 🛒 |
|--------------|----------------------|---------------------|---|
| 4 VS-FF-L-M | 10 | 1/2" | 1 |
| 5 VS-FF-L-M | 20 | 3/4" | 1 |
| 6 VS-FF-L-M | 25 | 1" | 1 |
| 11 VS-FF-L-M | 32 | 1"-1/4 | 1 |
| 12 VS-FF-L-M | 40 | 1"-1/2 | 1 |
| 13 VS-FF-L-M | 50 | 2" | 1 |

VS-MF-B-M



| COD | NORMA DIN DIN STD | DIMENSIONI SIZES | 🛒 |
|-------------|----------------------|---------------------|---|
| 4 VS-MF-B-M | 15 | 1/2" | 1 |
| 5 VS-MF-B-M | 20 | 3/4" | 1 |
| 6 VS-MF-B-M | 25 | 1" | 1 |

| COD | NORMA DIN DIN STD | DIMENSIONI SIZES | 🛒 |
|-----|----------------------|---------------------|---|
| | | | |
| | | | |
| | | | |

VSD-3FR-L-M



| COD | NORMA DIN DIN STD | DIMENSIONI SIZES | 🛒 |
|----------------|----------------------|---------------------|---|
| 2 VSD-3FR-L-M | 10 | 1/4" | 1 |
| 3 VSD-3FR-L-M | 10 | 3/8" | 1 |
| 4 VSD-3FR-L-M | 15 | 1/2" | 1 |
| 5 VSD-3FR-L-M | 20 | 3/4" | 1 |
| 6 VSD-3FR-L-M | 25 | 1" | 1 |
| 11 VSD-3FR-L-M | 32 | 1"-1/4 | 1 |
| 12 VSD-3FR-L-M | 40 | 1"-1/2 | 1 |
| 13 VSD-3FR-L-M | 50 | 2" | 1 |

VSD-3FR-T-M



| COD | NORMA DIN DIN STD | DIMENSIONI SIZES | 🛒 |
|--------------|----------------------|---------------------|---|
| 2 VSD-3FR-T | 10 | 1/4" | 1 |
| 3 VSD-3FR-T | 10 | 3/8" | 1 |
| 4 VSD-3FR-T | 15 | 1/2" | 1 |
| 5 VSD-3FR-T | 20 | 3/4" | 1 |
| 6 VSD-3FR-T | 25 | 1" | 1 |
| 11 VSD-3FR-T | 32 | 1"-1/4 | 1 |
| 12 VSD-3FR-T | 40 | 1"-1/2 | 1 |
| 13 VSD-3FR-T | 50 | 2" | 1 |

VS-3FR-L-M



| COD | NORMA DIN DIN STD | DIMENSIONI SIZES | 🛒 |
|---------------|----------------------|---------------------|---|
| 2 VS-3FR-L-M | 10 | 1/4" | 1 |
| 3 VS-3FR-L-M | 10 | 3/8" | 1 |
| 4 VS-3FR-L-M | 15 | 1/2" | 1 |
| 5 VS-3FR-L-M | 20 | 3/4" | 1 |
| 6 VS-3FR-L-M | 25 | 1" | 1 |
| 11 VS-3FR-L-M | 32 | 1"-1/4 | 1 |
| 12 VS-3FR-L-M | 40 | 1"-1/2 | 1 |
| 13 VS-3FR-L-M | 50 | 2" | 1 |

VS-3FR-T-M



| COD | NORMA DIN DIN STD | DIMENSIONI SIZES | 🛒 |
|-------------|----------------------|---------------------|---|
| 2 VS-3FR-T | 10 | 1/4" | 1 |
| 3 VS-3FR-T | 10 | 3/8" | 1 |
| 4 VS-3FR-T | 15 | 1/2" | 1 |
| 5 VS-3FR-T | 20 | 3/4" | 1 |
| 6 VS-3FR-T | 25 | 1" | 1 |
| 11 VS-3FR-T | 32 | 1"-1/4 | 1 |
| 12 VS-3FR-T | 40 | 1"-1/2 | 1 |
| 13 VS-3FR-T | 50 | 2" | 1 |

VS-3FT-L-M



| COD | NORMA DIN DIN STD | DIMENSIONI SIZES | 🛒 |
|---------------|----------------------|---------------------|---|
| 2 VS-3FT-L-M | 10 | 1/4" | 1 |
| 3 VS-3FT-L-M | 10 | 3/8" | 1 |
| 4 VS-3FT-L-M | 15 | 1/2" | 1 |
| 5 VS-3FT-L-M | 20 | 3/4" | 1 |
| 6 VS-3FT-L-M | 25 | 1" | 1 |
| 11 VS-3FT-L-M | 32 | 1"-1/4 | 1 |
| 12 VS-3FT-L-M | 40 | 1"-1/2 | 1 |
| 13 VS-3FT-L-M | 50 | 2" | 1 |

VS-3FT-T-M



| COD | NORMA DIN DIN STD | DIMENSIONI SIZES | 🛒 |
|---------------|----------------------|---------------------|---|
| 2 VS-3FT-T-M | 10 | 1/4" | 1 |
| 3 VS-3FT-T-M | 10 | 3/8" | 1 |
| 4 VS-3FT-T-M | 15 | 1/2" | 1 |
| 5 VS-3FT-T-M | 20 | 3/4" | 1 |
| 6 VS-3FT-T-M | 25 | 1" | 1 |
| 11 VS-3FT-T-M | 32 | 1"-1/4 | 1 |
| 12 VS-3FT-T-M | 40 | 1"-1/2 | 1 |
| 13 VS-3FT-T-M | 50 | 2" | 1 |

| COD | NORMA DIN DIN STD | DIMENSIONI SIZES | 🛒 |
|-----|----------------------|---------------------|---|
| | | | |
| | | | |
| | | | |

| COD | NORMA DIN DIN STD | DIMENSIONI SIZES | 🛒 |
|-----|----------------------|---------------------|---|
| | | | |
| | | | |
| | | | |

VS-P



MATERIALE: UPVC (Polivinilcloruro)
 PARTICOLARMENTE INDICATA PER USO CHIMICO ED ALIMENTARE
MATERIAL: UPVC (POLYVINYL CHLORIDE)
PARTICULARLY SUITABLE FOR CHEMICAL AND FOOD USE

A RICHIESTA DISPONIBILE ANCHE A 3 VIE
3 WAYS AVAILABLE ON REQUEST

ATTUATORE FORNIBILE A RICHIESTA
ACTUATOR AVAILABLE ON REQUEST

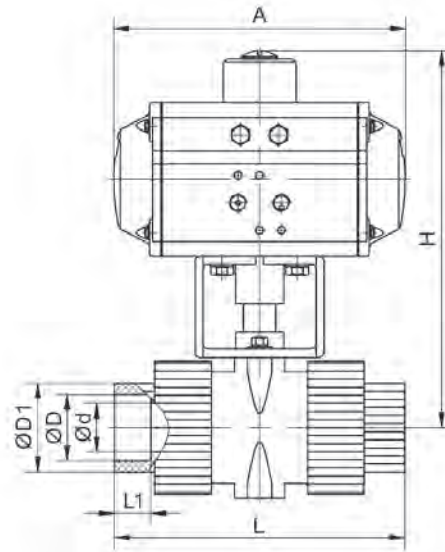

| COD | DN | D | D1 | d | L | L1 | A | H | ATTUATORE PNEUMATICO <i>PNEUMATIC ACTUATOR</i> | 🛒 |
|--------|-----|-----|-----|----|-----|----|-----|-----|---|---|
| 1 VS-P | 15 | 20 | 31 | 13 | 164 | 15 | 146 | 175 | AT 050 D | 1 |
| 2 VS-P | 20 | 25 | 37 | 18 | 182 | 17 | 146 | 180 | AT 050 D | 1 |
| 3 VS-P | 25 | 33 | 44 | 23 | 210 | 20 | 146 | 187 | AT 050 D | 1 |
| 4 VS-P | 32 | 40 | 54 | 30 | 233 | 23 | 167 | 220 | AT 063 D | 1 |
| 5 VS-P | 40 | 50 | 65 | 38 | 247 | 25 | 167 | 245 | AT 063 D | 1 |
| 6 VS-P | 50 | 63 | 79 | 48 | 291 | 28 | 213 | 250 | AT 075 D | 1 |
| 7 VS-P | 65 | 75 | 92 | 61 | 371 | 32 | 213 | 280 | AT 075 D | 1 |
| 8 VS-P | 80 | 90 | 108 | 69 | 414 | 35 | 250 | 332 | AT 092 D | 1 |
| 9 VS-P | 100 | 110 | 146 | 99 | 462 | 45 | 268 | 387 | AT 105 D | 1 |

I PREZZI INCLUDONO LA STAFFA DI MONTAGGIO
PRICES INCLUDE MOUNTING BRACKET

Con l'utilizzo di un' **INTERFACCIA** i segnali provenienti, tramite collegamenti tradizionali paralleli dalle Unità Remote distribuite nell'impianto, vengono trasformati in Collegamento Seriale e trasmessi, con un unico cavo, al **PLC** del Sistema.

The signals coming from Remote Units distributed in the pneumatic system are transformed through traditional parallels connections, in serial connections and transmitted, (using interface) through a single cable, to the system PLC.

Vantaggi della soluzione seriale:

- Velocità e semplicità di cablaggio
- Numero ridotto di ingressi/uscite sull'Unità Centrale
- Rapida individuazione dei guasti (Autodiagnosi)
- Riduzione dei costi (materiale, cablaggio, manutenzione)
- Rende più semplice l'espansione del Sistema

Advantage of the Serial Solution

- *Speed and simplicity of wiring*
- *Reduced number of inputs/outputs on the Central Unit*
- *Rapid fault finding (self-diagnosis)*
- *Cost reduction (material, wiring, maintenance)*
- *Makes system expansion easier*

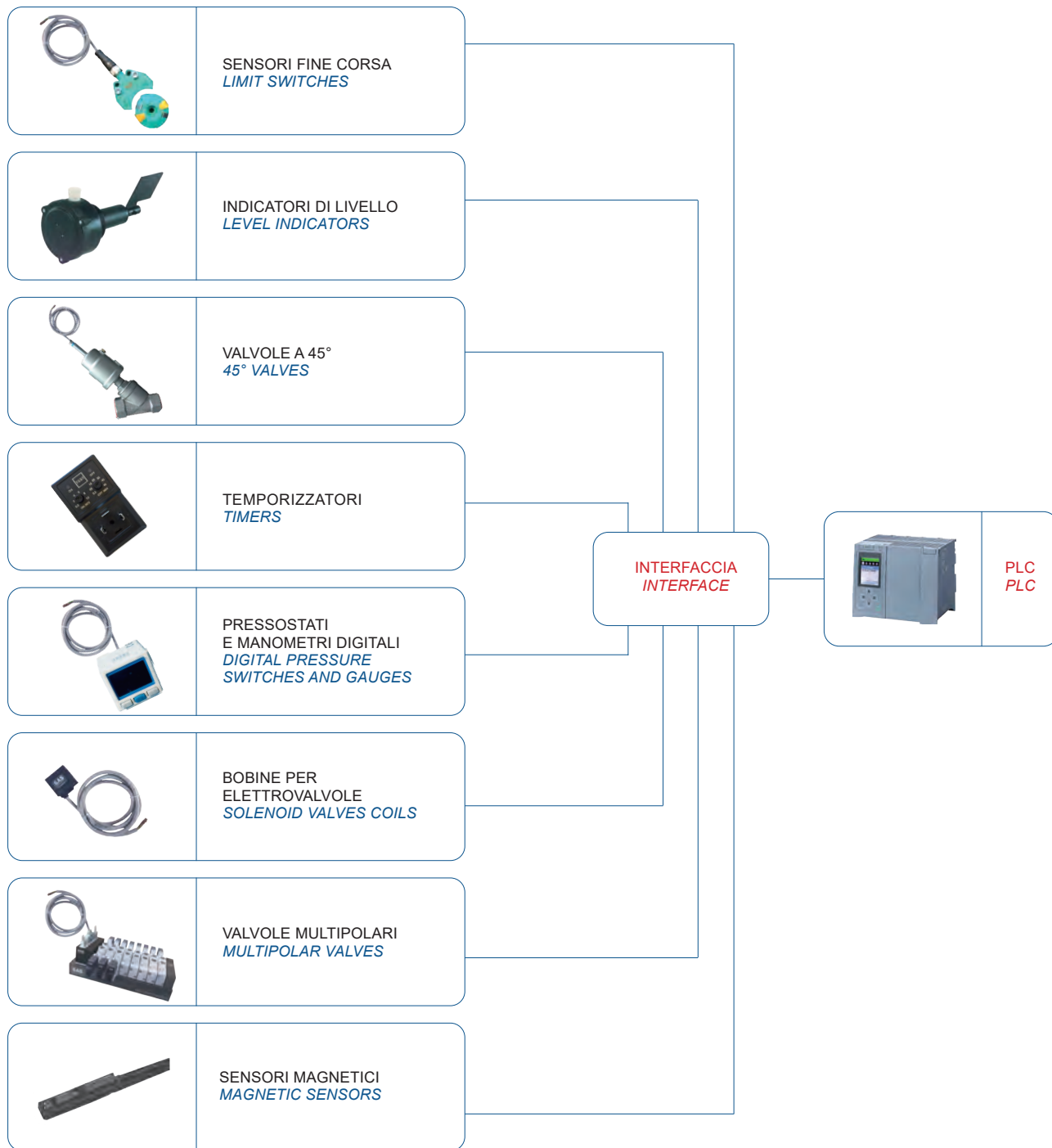

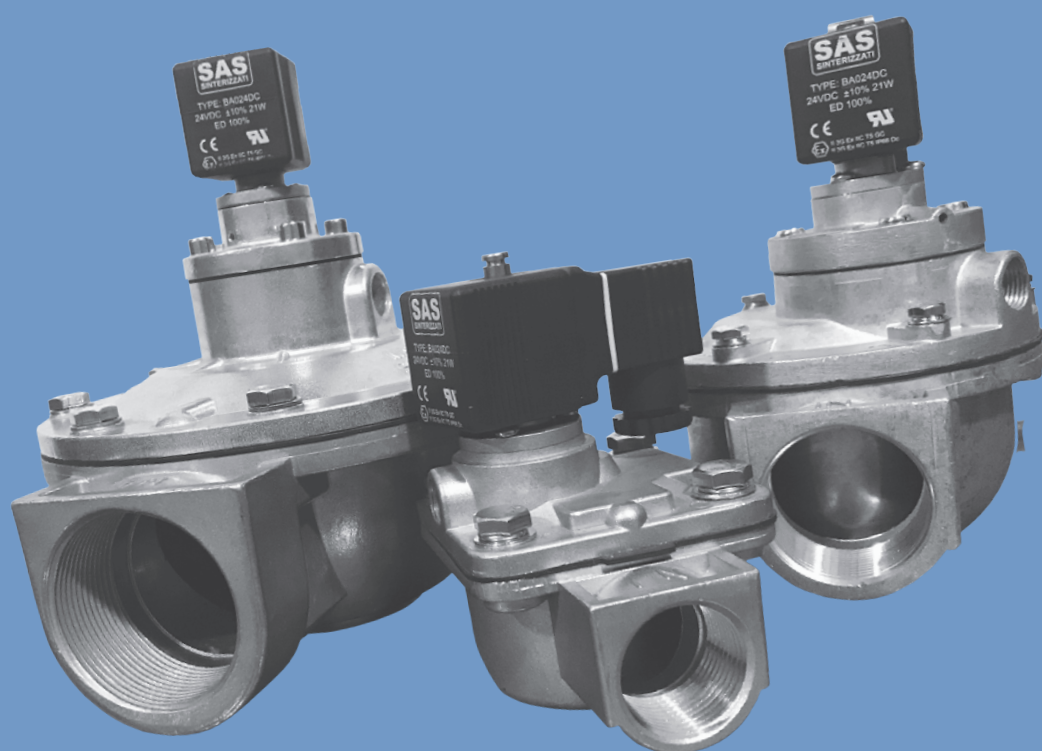

AUXILIARY VALVES

| | | | | | |
|---|---|-----|--|--|-----|
|  | PULSE VALVE PULSE VALVE | 187 |  | VP 2000 VALVOLE PROPORZIONALI PROPORTIONAL VALVES | 191 |
|  | VALVOLE 45° 45° VALVES | 187 |  | VP 1000 VALVOLE PROPORZIONALI PROPORTIONAL VALVES | 181 |
|  | VALVOLE 45° F 45° F VALVES | 187 |  | HVP7-2831 VALVOLE PROPORZIONALI A COMANDO DIRETTO POPPET PRESSURE REGULATOR VALVES | 193 |
|  | DRAIN VALVE DRAIN VALVE | 187 |  | VAP-I-08-40 VALVOLE AD ALTA PRESSIONE HIGH PRESSURE VALVES | 195 |
|  | DRAIN VALVE TEMPORIZZATA TIMED DRAIN VALVE | 187 |  | VAP-E-08-24 VALVOLE AD ALTA PRESSIONE HIGH PRESSURE VALVES | 195 |
|  | TIMER CONTROLLO MANUALE MANUAL CONTROL TIMER | 188 |  | VAP-I-15-24 - VAP-E-15-24 VALVOLE AD ALTA PRESSIONE HIGH PRESSURE VALVES | 195 |
|  | TIMER CONTROL DIGITALE DIGITAL CONTROL TIMER | 188 |  | VALVOLA DI PORTATA A REGOLAZ. ELETTRONICA TIPO A FLOW CONTROL ELECTRONIC VALVE - A TYPE | 196 |
|  | 2 W VALVOLE IN-LINE IN LINE VALVES | 188 |  | VALVOLA DI PORTATA A REGOLAZ. ELETTRONICA TIPO B FLOW CONTROL ELECTRONIC VALVE - B TYPE | 196 |
|  | KLS VALVOLE IN-LINE IN LINE VALVES | 189 |  | PRESSOSTATI DIGITALI DIGITAL PRESSURE SWITCHES | 197 |
|  | VP 3000 VALVOLE PROPORZIONALI PROPORTIONAL VALVES | 191 |  | MANOMETRI DIGITALI DIGITAL PRESSURE GAUGES | 197 |

VALVOLE AUSILIARIE - AUXILIARY VALVES

PULSE VALVE - PULSE VALVE

ATEX A RICHIESTA
ATEX ON REQUEST

| COD | DIMENSIONI SIZES | DN | 🛒 |
|--------|---------------------|----|---|
| PUL-15 | 1/2" | 15 | 1 |
| PUL-20 | 3/4" | 20 | 1 |
| PUL-25 | 1" | 25 | 1 |
| PUL-40 | 1" 1/2 | 40 | 1 |
| PUL-50 | 2" | 50 | 1 |
| PUL-65 | 2" 1/2 | 65 | 1 |
| PUL-80 | 3" | 80 | 1 |

| MATERIALE MATERIAL | VOLT VOLT | POWER POWER |
|------------------------|-----------------------------------|-------------------|
| ALLUMINIO ALUMINIUM | AC110V AC220V DC24V ±10% | DC 20W AC 25VA |

VALVOLE 45° - 45° VALVES

AISI 316 - ATEX A RICHIESTA
AISI 316 - ATEX ON REQUEST

| COD | DIMENSIONI SIZES | DN | G | ATTUATORE ACTUATOR | 🛒 |
|----------|---------------------|----|------|-----------------------|---|
| ANGLE-10 | 3/8" | 10 | 1/8" | Ø 40 | 1 |
| ANGLE-15 | 1/2" | 15 | 1/8" | Ø 50 | 1 |
| ANGLE-20 | 3/4" | 20 | 1/8" | Ø 50 | 1 |
| ANGLE-25 | 1" | 25 | 1/8" | Ø 50 | 1 |
| ANGLE-32 | 1"1/4 | 32 | 1/8" | Ø 63 | 1 |
| ANGLE-40 | 1" 1/2 | 40 | 1/8" | Ø 63 | 1 |
| ANGLE-50 | 2" | 50 | 1/8" | Ø 63 | 1 |
| ANGLE-65 | 2" 1/2 | 65 | 1/4" | Ø 90 | 1 |
| ANGLE-80 | 3" | 80 | 1/4" | Ø 125 | 1 |

TIPO CLAMP A RICHIESTA
CLAMP TYPE - ON REQUEST

| MATERIALE MATERIAL | CARATTERISTICHE FEATURES |
|---|---|
| STANDARD: AISI 316 A RICHIESTA: ALLUMINIO STANDARD: AISI 316 ON REQUEST: ALUMINIUM | STANDARD: DE-NC STANDARD: DE-NC A RICHIESTA: SE-NA ON REQUEST: SE-NA |

| |
|-----------------------------------|
| A: TEMP. MAX. DI UTILIZZO: 120 °C |
| B: TEMP. MAX. DI UTILIZZO: 160 °C |
| C: TEMP. MAX. DI UTILIZZO: 220 °C |
| A: MAX. OPERATING TEMP.: 120 °C |
| B: MAX. OPERATING TEMP.: 160 °C |
| C: MAX. OPERATING TEMP.: 220 °C |

VALVOLE 45° F - 45° F VALVES

AISI 316 - ATEX A RICHIESTA
AISI 316 - ATEX ON REQUEST

| COD | DIMENSIONI SIZES | DN | G | ATTUATORE ACTUATOR | 🛒 |
|------------|---------------------|----|------|-----------------------|---|
| ANGLE-10 F | 3/8" | 10 | 1/8" | Ø 40 | 1 |
| ANGLE-15 F | 1/2" | 15 | 1/8" | Ø 50 | 1 |
| ANGLE-20 F | 3/4" | 20 | 1/8" | Ø 50 | 1 |
| ANGLE-25 F | 1" | 25 | 1/8" | Ø 50 | 1 |
| ANGLE-32 F | 1"1/4 | 32 | 1/8" | Ø 63 | 1 |
| ANGLE-40 F | 1" 1/2 | 40 | 1/8" | Ø 63 | 1 |
| ANGLE-50 F | 2" | 50 | 1/8" | Ø 63 | 1 |
| ANGLE-65 F | 2" 1/2 | 65 | 1/4" | Ø 90 | 1 |
| ANGLE-80 F | 3" | 80 | 1/4" | Ø 125 | 1 |

| MATERIALE MATERIAL | CARATTERISTICHE FEATURES |
|---|---|
| STANDARD: AISI 316 A RICHIESTA: ALLUMINIO STANDARD: AISI 316 ON REQUEST: ALUMINIUM | STANDARD: DE-NC STANDARD: DE-NC A RICHIESTA: SE-NA ON REQUEST: SE-NA |

| |
|---|
| STANDARD: CON SENSORE FINE CORSA TEMPERATURA MAX. DI UTILIZZO: 80 °C |
| STANDARD: WITH LIMIT SWITCH MAX. OPERATING TEMP.: 80 °C |

DRAIN VALVE - DRAIN VALVE



| COD | DIMENSIONI SIZES | 🛒 |
|-------|---------------------|---|
| DRAIN | 1/2" | 1 |

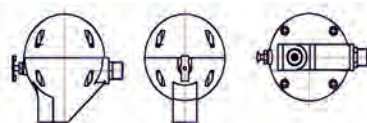

| MATERIALE MATERIAL | CARATTERISTICHE FEATURES |
|-----------------------|---|
| ALLUMINIO - ALUMINIUM | PRESSIONE: 0 + 8,0 BAR TEMPERATURA: -10 + +80 °C PRESSURE: 0 + 8,0 BAR TEMPERATURE: -10 + +80 °C |

DRAIN VALVE TEMPORIZZATA - TIMED DRAIN VALVE

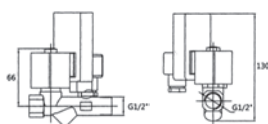

| COD | DIMENSIONI - SIZES | 🛒 |
|---------|--------------------|---|
| DRAIN-T | 1/2" | 1 |

CON VALVOLA A SFERA
WITH BALL VALVE

| | | | |
|---------|------|---------|---|
| DRAIN-R | 1/2" | DRAIN-R | 1 |
|---------|------|---------|---|

SENZA VALVOLA A SFERA
WITHOUT BALL VALVE

| MATERIALE - MATERIAL | CARATTERISTICHE FEATURES |
|----------------------|--|
| OTTONE - BRASS | NORMALMENTE CHIUSA PRESSIONE DI UTILIZZO: 0 + 16,0 BAR TEMPERATURA: 0 + +80 °C NORMALLY CLOSED OPERATING PRESS: 0 + 16,0 BAR OPERATING TEMP: 0 + +80 °C |

VALVOLE AUSILIARIE - AUXILIARY VALVES

TEMPORIZZATORI - TIMERS

TIMER CONTROLLO MANUALE
MANUAL CONTROL TIMERCOD
TC-M 1

CARATTERISTICHE - FEATURES

VOLTAGGIO: 24V-240V
AC/DC - 50/60 HZ
SWITCH 1 AMP - IP 65
VOLTAGE 24V-240V
AC/DC - 50/60 HZ
SWITCH 1 AMP - IP 65TIMER CONTROL DIGITALE
DIGITAL CONTROL TIMERCOD
TC-D 1

CARATTERISTICHE - FEATURES

VOLTAGGIO: 24V-240V
AC/DC - 50/60 HZ
SWITCH 1 AMP - IP 65
VOLTAGE 24V-240V
AC/DC - 50/60 HZ
SWITCH 1 AMP - IP 65

VALVOLE IN-LINE - IN LINE VALVES

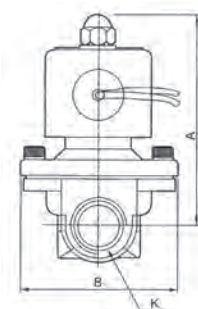
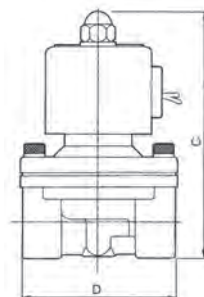
PT 1/4"
PT 3/8"
PT 1/2"
PT 3/4"
PT 1"PT 1" 1/4
PT 1" 1/2
PT 2"MATERIALE: OTTONE NON NICHELATO
DISPONIBILI A RICHIESTA IN AISI 316 LMATERIAL: NOT NICKEL PLATED BRASS
AVAILABLE ON REQUEST IN AISI 316 L

DIMENSIONI - SIZES

| COD | A | B | C | D | K | NA | NC |
|-------------|-----|-----|-----|-----|----------|----|----|
| 2W 160 - 06 | | | | | | | |
| 2W 160 - 08 | 93 | 56 | 106 | 69 | PT 1/4" | 1 | 1 |
| 2W 160 - 10 | 93 | 56 | 106 | 69 | PT 3/8" | 1 | 1 |
| 2W 160 - 15 | 93 | 56 | 106 | 69 | PT 1/2" | 1 | 1 |
| 2W 200 - 20 | 100 | 56 | 117 | 73 | PT 3/4" | 1 | 1 |
| 2W 250 - 25 | 104 | 78 | 125 | 99 | PT 1" | 1 | 1 |
| 2W 350 - 35 | 141 | 93 | 172 | 124 | PT 1"1/4 | 1 | 1 |
| 2W 400 - 40 | 141 | 93 | 172 | 124 | PT 1"1/2 | 1 | 1 |
| 2W 500 - 50 | 157 | 124 | 195 | 172 | PT 2" | 1 | 1 |

PARAMETRI - PARAMETERS

| COD | FLUIDO FLUID | VERSIONE VERSION | TIPO TYPE | DN DN (mm) | CV CV | CONNESSIONE PORTA PORT CONNECTION | VISCOSITÀ FLUIDO VISCOSITY | PRESSIONE DI ESERCIZIO WORKING PRESSURE (Bar) | PRESSIONE MASSIMA MAX. PRESSURE (Bar) | TEMP. AMBIENTE TEMP. (°C) | TOLLERANZA VOLTAGGIO VOLTAGE TOLLERANCE | CORPO VALVOLA BODY | TENUTE SEAL |
|-----------|-----------------|---------------------|--------------|------------------|----------|--|----------------------------------|---|---|------------------------------------|--|--------------------------|----------------|
| 2W 160-06 | | | | 16 | 4,8 | 1/8" | | | | | | | |
| 2W 160-08 | | | | 16 | 4,8 | 1/4" | | | | | | | |
| 2W 160-10 | ARIA | COMANDO | NORM. | 16 | 4,8 | 3/8" | | ARIA - AIR 0 ~ 10 | | | | | NBR |
| 2W 160-15 | ACQUA | DIRETTO | CHIUSO | 16 | 4,8 | 1/2" | | ACQUA - WATER 0 ~ 7 | 10 | - 5 ~ 80 | ± 10% | OTTONE BRASS | EPDM VITON |
| 2W 200-20 | OLIO | DIRETTO | NORM. | 20 | 7,6 | 3/4" | < 20 CST < 20 CST | | | | | | NBR |
| 2W 250-25 | AIR | DIRECT | CLOSED | 25 | 12 | 1" | | | | | | | EPDM VITON |
| 2W 350-35 | WATER | ACTING | | 35 | 24 | 1"1/4 | | OLIO - OIL 0 ~ 7 | | | | | |
| 2W 400-40 | OIL | | | 40 | 29 | 1"1/2 | | | | | | | |
| 2W 500-50 | | | | 50 | 48 | 2" | | | | | | | |

IMPORTANTE: Nella stesura dell'ordine specificare il tipo di bobina (AC o DC) e il tipo di valvola (NA o NC).
IMPORTANT: When drawing up the order, specify the type of coil (AC or DC) and the type of valve (NO or NC).

VALVOLE IN-LINE - IN-LINE VALVES

KLS-08
KLS-10



MATERIALE: AISI 304
MATERIAL: AISI 304

KLS-15
KLS-20
KLS-25
KLS-32
KLS-40
KLS-50



MATERIALE: AISI 304
MATERIAL: AISI 304

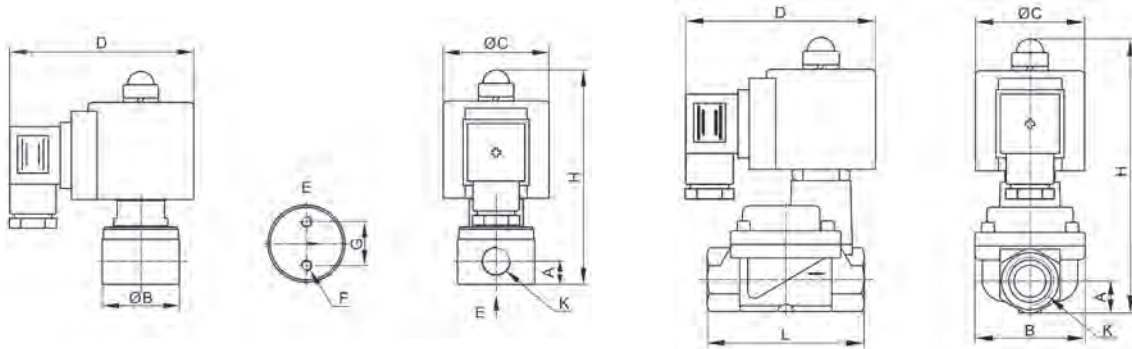

DIMENSIONI - SIZES

| COD | A | ØB | ØC | D | F | G | K | H | L |
|-----------|------|------|----|------|----|----|----------|-----|-----|
| KLS-08 | 10,5 | 35 | 48 | 83,5 | M5 | 20 | G 1/4" | 89 | |
| KLS-08-NO | 10,5 | 35 | 48 | 83,5 | M5 | 20 | G 1/4" | 96 | |
| KLS-10 | 11,5 | 44 | 48 | 83,5 | M5 | 27 | G 3/8" | 93 | |
| KLS-10-NO | 11,5 | 44 | 48 | 83,5 | M5 | 27 | G 3/8" | 100 | |
| KLS-15 | 14 | 48,5 | 48 | 83,5 | | | G 1/2" | 121 | 69 |
| KLS-20 | 18 | 55,5 | 48 | 83,5 | | | G 3/4" | 133 | 79 |
| KLS-25 | 21 | 70 | 48 | 83,5 | | | G 1" | 142 | 96 |
| KLS-32 | 27 | 70 | 48 | 83,5 | | | G 1 1/4" | 152 | 109 |
| KLS-40 | 31 | 95 | 48 | 83,5 | | | G 1 1/2" | 167 | 128 |
| KLS-50 | 38 | 100 | 48 | 83,5 | | | G 2" | 183 | 150 |

PARAMETRI - PARAMETERS

| COD | DN DN | CONNESSIONE PORTE PORT CONNECTION | VISCOSITÀ FLUIDO FLUIDO VISCOSITY | PRESSIONE DI ESERCIZIO WORKING PRESSURE | TEMPERATURA MASSIMA MAX. TEMPERATURE | CORPO VALVOLA BODY | TENUTE SEAL | NA 🛒 | NC 🛒 |
|------------|----------|--|--|--|---|--------------------------|---|---------|---------|
| KLS-08-2 | 2 | 1/4" | 50 CST | 0 + 12 BAR | FPN = 150 °C | AISI 304 | FPN A RICHIESTA PTFE EPDM FPN ON REQUEST PTFE EPDM | 1 | 1 |
| KLS-08-2.5 | 2,5 | 1/4" | | | FPN = 150 °C | | | 1 | 1 |
| KLS-08-3 | 3 | 1/4" | | | FPN = 150 °C | | | 1 | 1 |
| KLS-08-4 | 4 | 1/4" | | | FPN = 150 °C | | | 1 | 1 |
| KLS-08-5 | 5 | 1/4" | | | FPN = 150 °C | | | 1 | 1 |
| KLS-10-2 | 2 | 3/8" | | | EPDM = 120 °C | | | 1 | 1 |
| KLS-10-2.5 | 2,5 | 3/8" | | | EPDM = 120 °C | | | 1 | 1 |
| KLS-10-3 | 3 | 3/8" | | | EPDM = 120 °C | | | 1 | 1 |
| KLS-10-4 | 4 | 3/8" | | | EPDM = 120 °C | | | 1 | 1 |
| KLS-10-5 | 5 | 3/8" | | | EPDM = 120 °C | | | 1 | 1 |
| KLS-15 | 15 | 1/2" | | | PTFE = 180 °C | | | 1 | 1 |
| KLS-20 | 20 | 3/4" | | | PTFE = 180 °C | | | 1 | 1 |
| KLS-25 | 25 | 1" | | | PTFE = 180 °C | | | 1 | 1 |
| KLS-32 | 32 | 1" 1/4" | | | PTFE = 180 °C | | | 1 | 1 |
| KLS-40 | 40 | 1" 1/2" | | | PTFE = 180 °C | | | 1 | 1 |
| KLS-50 | 50 | 2" | PTFE = 180 °C | 1 | 1 | | | | |

VALVOLE IN-LINE - IN-LINE VALVES

MATERIALE:
OTTONE NON NICHELATO

*MATERIAL:
NOT NICKEL PLATED
BRASS*



KLS-08
KLS-10

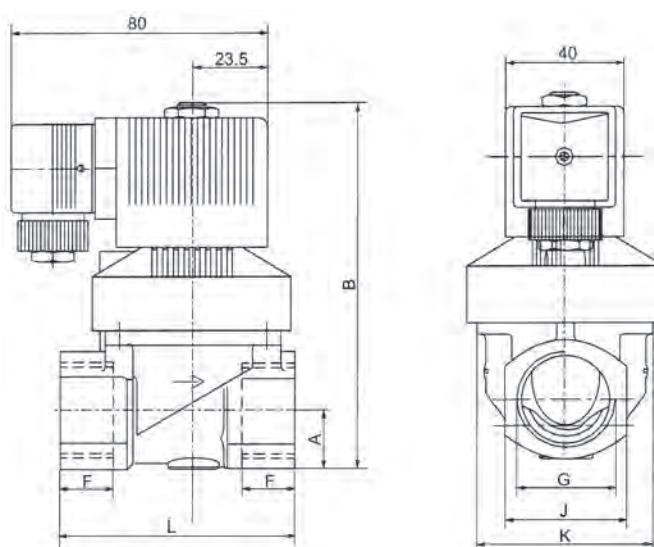

DIMENSIONI - SIZES

| COD | G | F | H | K | L | E | B | A |
|------------|---------|----|----|----|----|----|-----|----|
| KL 5231008 | ZG 1/4" | 12 | 40 | 34 | 64 | 24 | 97 | 16 |
| KL 5231010 | ZG 3/8" | 12 | 40 | 34 | 64 | 24 | 97 | 16 |
| KL 5231015 | ZG 1/2" | 12 | 40 | 34 | 64 | 24 | 97 | 16 |
| KL 5231020 | ZG 3/4" | 16 | 40 | 60 | 92 | 45 | 124 | 20 |
| KL 5231025 | ZG 1" | 18 | 40 | 60 | 92 | 45 | 124 | 20 |

PARAMETRI - PARAMETERS

| COD | DN DN | CONNESSIONE PORTE PORT CONNECTION | VISCOSITÀ FLUIDO VISCOSITY | PRESSIONE DI ESERCIZIO WORKING PRESSURE | TEMPERATURA MASSIMA MAX. TEMPERATURE | CORPO VALVOLA BODY | TENUTE SEAL | NA ☐ | NC ☐ |
|----------|----------|--|-------------------------------|--|---|--------------------------|----------------|---------|---------|
| KLS-H-08 | 13 | 1/4" | 0,01 CST | 3 + 50 BAR | 180 °C | OTTONE - BRASS | PTFE | 1 | 1 |
| KLS-H-10 | 13 | 3/8" | 0,01 CST | 3 + 50 BAR | 180 °C | OTTONE - BRASS | PTFE | 1 | 1 |
| KLS-H-15 | 13 | 1/2" | 0,01 CST | 3 + 50 BAR | 180 °C | OTTONE - BRASS | PTFE | 1 | 1 |
| KLS-H-20 | 25 | 3/4" | 0,01 CST | 3 + 35 BAR | 180 °C | OTTONE - BRASS | PTFE | 1 | 1 |
| KLS-H-25 | 25 | 1" | 0,01 CST | 3 + 35 BAR | 180 °C | OTTONE - BRASS | PTFE | 1 | 1 |

VALVOLE PROPORZIONALI - PROPORTIONAL VALVES



| COD | ATTACCO BSPP BSPP CONNECTION | INGRESSO INLET | USCITA OUTLET | PRESSIONE PRESSURE | CORRENTE POWER SUPPLY | 🛒 |
|----------|---------------------------------|--|---|-----------------------|-----------------------------|---|
| VP-1000 | 1/8" - 1/4" | 4÷20 mA - 0÷20 mA - 0÷5 VDC - 0÷10 VDC | 1÷5 VDC - dig. NPN - dig. PNP - 4÷20 mA | 0÷0,1 MPa | 24 DC | 1 |
| VP-2000 | 1/8" - 3/8" | 4÷20 mA - 0÷20 mA - 0÷5 VDC - 0÷10 VDC | 1÷5 VDC - dig. NPN - dig. PNP - 4÷20 mA | 0÷0,5 MPa | 24 DC | 1 |
| VP-2040* | 3/8" - 1/2" | 4÷20 mA - 0÷20 mA - 0÷5 VDC - 0÷10 VDC | 1÷5 VDC - dig. NPN - dig. PNP - 4÷20 mA | 0÷3,0 MPa | 24 DC | 1 |
| VP-3000 | 1/4" - 1/2" | 4÷20 mA - 0÷20 mA - 0÷5 VDC - 0÷10 VDC | 1÷5 VDC - dig. NPN - dig. PNP - 4÷20 mA | 0÷0,9 MPa | 24 DC | 1 |

DATI TECNICI:

Temperatura di esercizio: max 50 °C
 Gamma di pressioni (a seconda del modello): 0,05 ÷ 3 MPa
 Tolleranza a 25 °C: ± 2%

APPLICAZIONI:

Fluidi: Aria, Gas non corrosivi e incombustibili

SPECIFICHE TECNICHE:

Tensione di alimentazione: da 12 Vdc A 24 VDC ± 10%
 2 uscite digitali: NPN oppure PNP
 Uscite Analogiche: 4 - 20 mA oppure 1 - 5 VDC

1 Bar = 0,1 MPa

TECHNICAL DATA:

Operating temperature: max 50 °C
 Pressure range (depending on the model): 0.05 ÷ 3 MPa
 Tolerance at 25 °C: ± 2%

APPLICATIONS:

Fluids: Air, non-corrosive and incombustible gases

TECHNICAL SPECIFICATIONS:

Power supply voltage: from 12 VDC to 24 VDC ± 10%
 2 digital outputs: NPN or PNP
 Analogic outputs: 4 - 20 mA or 1 - 5 VDC

1 Bar = 0,1 MPa

VALVOLE AUSILIARIE - AUXILIARY VALVES

COME ORDINARE

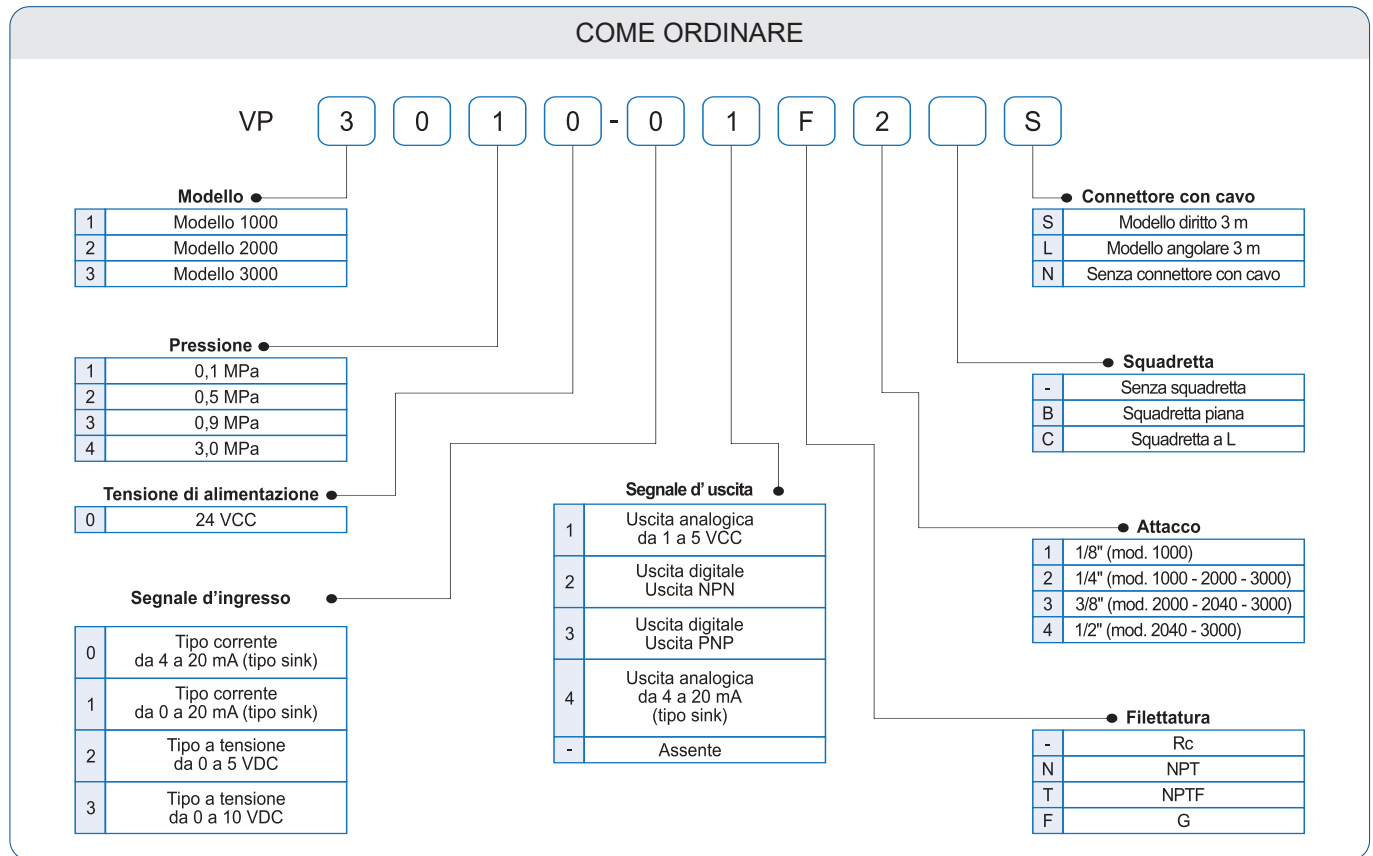

HOW TO ORDER

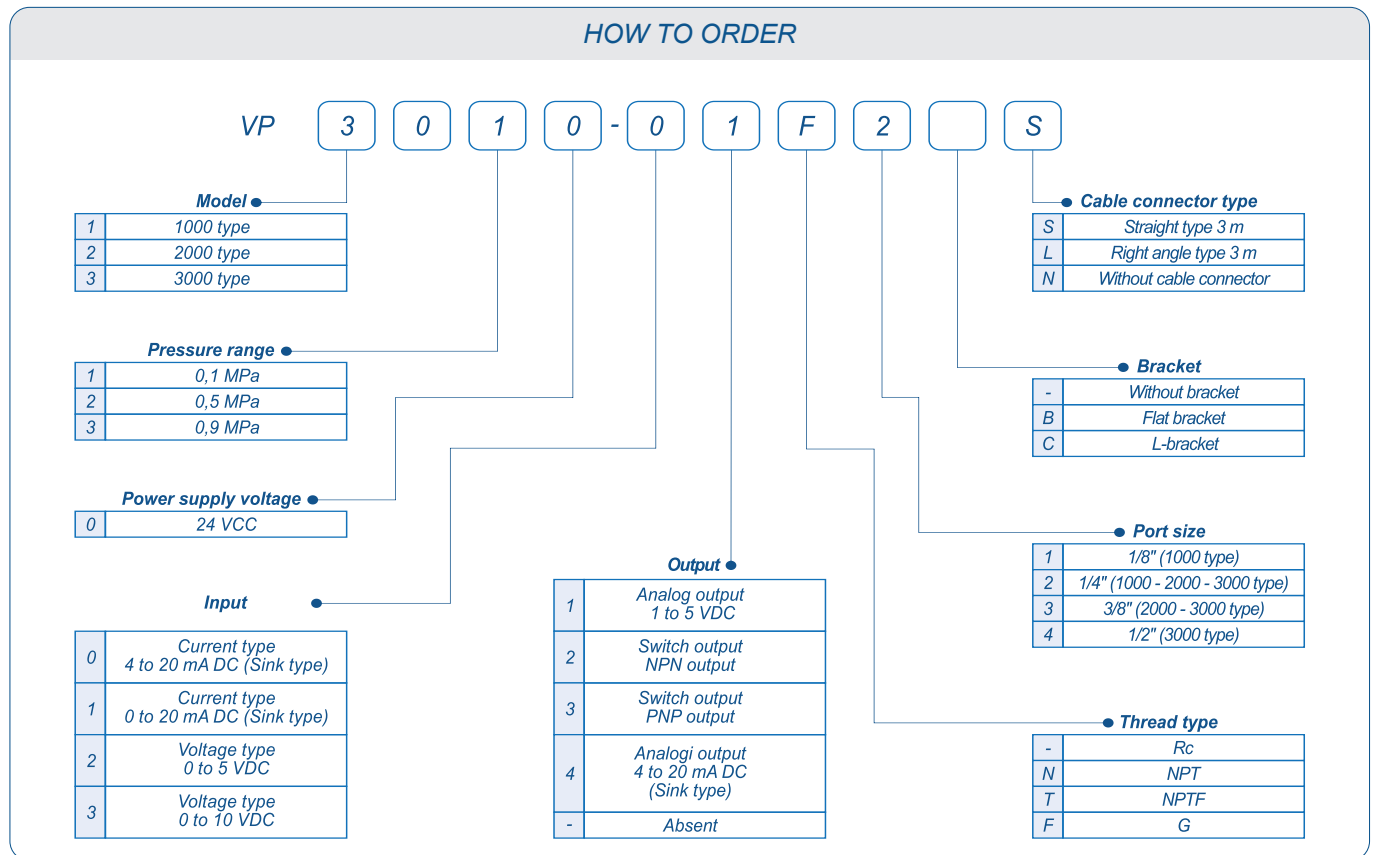

VALVOLE PROPORZIONALI A COMANDO DIRETTO - POPPET PRESSURE REGULATOR VALVES

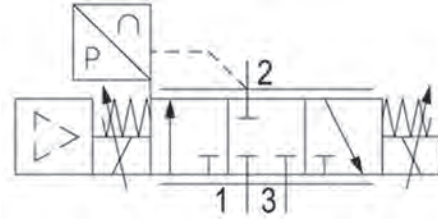

HVP7-2831

| COD | ATTACCO BSPP BSPP CONNECTION | INGRESSO INLET | USCITA OUTLET | PRESSIONE PRESSURE | CORRENTE POWER SUPPLY | 🛒 |
|-------------|---------------------------------|-------------------|------------------|-----------------------|-----------------------------|---|
| HVP7-2831-3 | 3/8" | 0+10 V - 4+20 mA | 0+5 V - 4+20 mA | 0+28 Bar | 24 V | 1 |
| HVP7-2831-4 | 1/2" | 0+10 V - 4+20 mA | 0+5 V - 4+20 mA | 0+28 Bar | 24 V | 1 |

DATI TECNICI:

Temperatura di esercizio: max 50 °C
 Gamma di pressioni (a seconda del modello): 0,05 ÷ 30 MPA
 Tolleranza a 25 °C: ± 2%

APPLICAZIONI: Fluidi: Aria, Gas non corrosivi e incombustibili

SPECIFICHE TECNICHE:

Controllo: Analogico
 Portata nominale: 1300 l/min (input 7 bar - output 6 bar)
 Tensione di alimentazione: 24 VDC

1 Bar = 0,1 MPa

TECHNICAL DATA:

Operating temperature: max 50 °C
 Pressure range (depending on the model): 0.05 ÷ 30 MPA
 Tolerance at 25 °C: ± 2%

APPLICATIONS: Fluids: Air, non-corrosive and incombustible gases

TECHNICAL SPECIFICATIONS:

Control: Analog
 Nominal flow: 1300 l/min (input 7 bar - output 6 bar)
 Operating voltage: 24 VDC

1 Bar = 0,1 MPa

COME ORDINARE

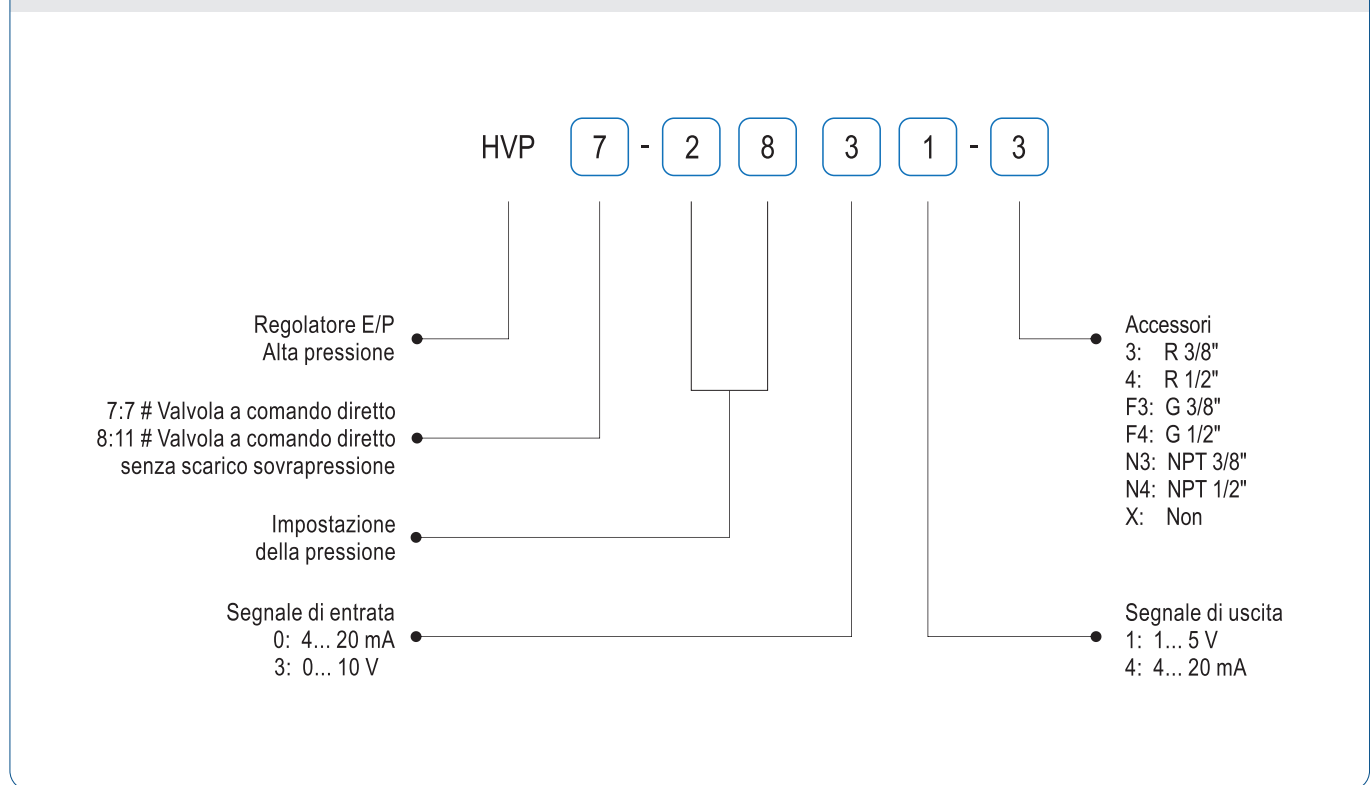

HOW TO ORDER

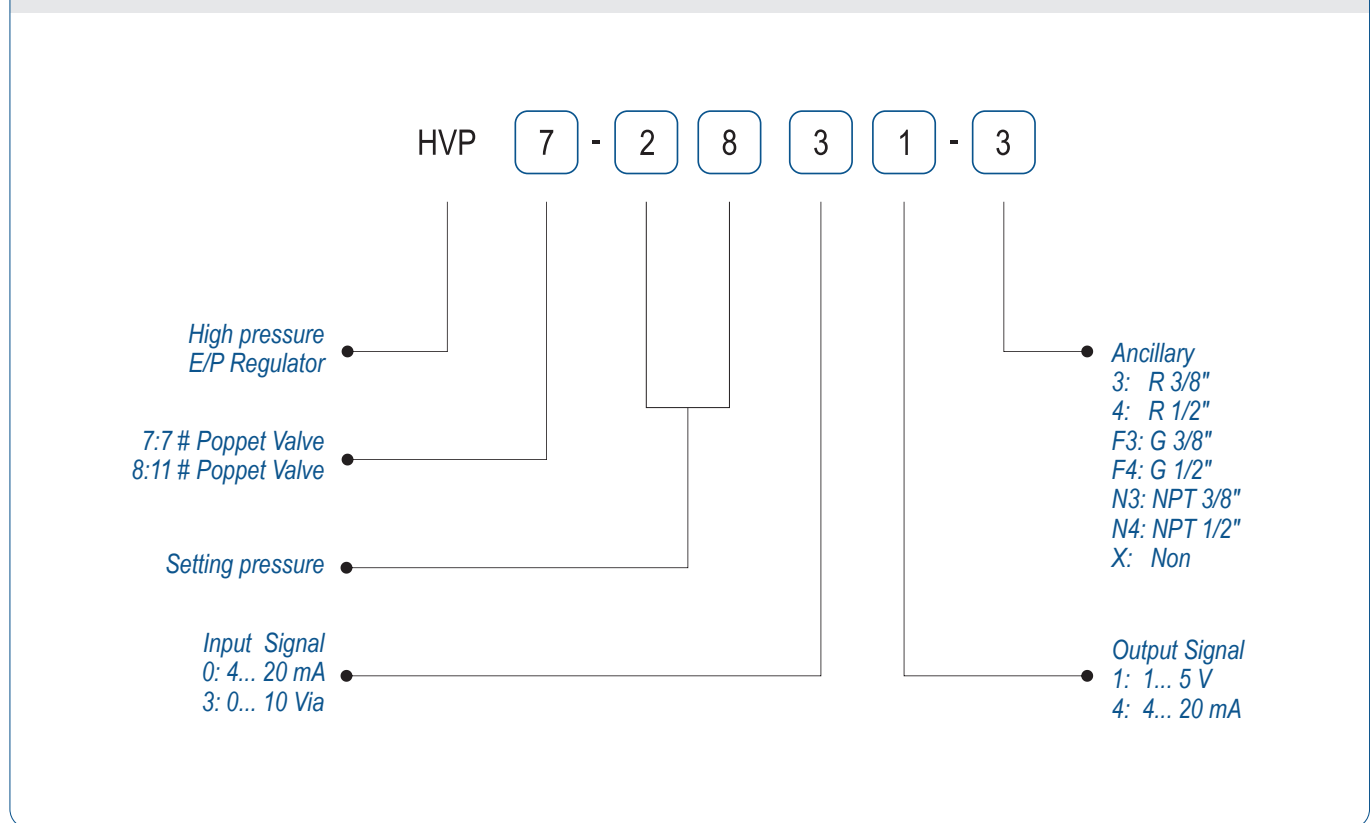

VALVOLE AD ALTA PRESSIONE - HIGH PRESSURE VALVES



MATERIALE: OTTONE NON NICHELATO
 MATERIAL: NOT NICKELLED BRASS

| COD | DESCRIZIONE - DESCRIPTION | |
|-------------|---|---|
| VAP-I-08-40 | Valvola ad alta pressione colore giallo - 3/2 vie - DC 24 V - 0 ÷ 40 bar - Pilotaggio interno High pressure valve yellow color - 3/2 ways - DC 24 V - 0 ÷ 40 bar - Internal pilot | 1 |
| VAP-E-08-24 | Valvola ad alta pressione colore giallo - 3/2 vie - DC 24 V - 0 ÷ 24 bar - Dimensione porta G 1/4" - Pilotaggio esterno High pressure valve yellow color - 3/2 ways - DC 24 V - 0 ÷ 24 bar - Port size G 1/4" - External pilot | 1 |
| VAP-I-15-24 | Valvola ad alta pressione colore giallo - 3/2 vie - DC 24 V - 0 ÷ 24 bar - Dimensione porta G 1/2" - Pilotaggio interno High pressure valve yellow color - 3/2 ways - DC 24 V - 0 ÷ 24 bar - Port size G 1/2" - External pilot | 1 |
| VAP-E-15-24 | Valvola ad alta pressione colore giallo - 3/2 vie - DC 24 V - 0 ÷ 24 bar - Dimensione porta G 1/2" - Pilotaggio esterno High pressure valve yellow color - 3/2 ways - DC 24 V - 0 ÷ 24 bar - Port size G 1/2" - External pilot | 1 |

SCHEDA TECNICA - DATA SHEET

| MODELLO / MODEL | VAP-I-08-40 | VAP-E-08-24 | VAP-I-15-24 | VAP-E-15-24 |
|---|--|----------------------------|----------------------------|----------------------------|
| Passaggio DN | 8 mm | 8 mm | 15 mm | 15 mm |
| Pressione di lavoro Working pressure | 0 ÷ 24 bar (40 Bar versione 8 mm pilotaggio interno) 0 ÷ 24 bar (40 Bar 8 mm version internal piloting) | | | |
| Tempo di commutazione Switching time | ≤ 0,04 s | ≤ 0,04 s | ≤ 0,08 s | ≤ 0,08 s |
| Selezione effettiva Effective sectional area | ≥ 20 mm ² | ≥ 20 mm ² | ≥ 60 mm ² | ≥ 60 mm ² |
| Temperatura massima di servizio Max. working temperature | 55 °C | 55 °C | 55 °C | 55 °C |
| Temperatura media di lavoro Working temperature | -5 °C ÷ 55 °C | -5 °C ÷ 55 °C | -5 °C ÷ 55 °C | -5 °C ÷ 55 °C |
| Durata della valvola Life | > 1.500.000 Cicli - Cycles | > 1.500.000 Cicli - Cycles | > 1.500.000 Cicli - Cycles | > 1.500.000 Cicli - Cycles |

COME ORDINARE - HOW TO ORDER

VAP

TIPO:
Valvola alta pressione
TYPE:
High pressure valve

I

I = Pilotaggio interno
E = Pilotaggio esterno
I = Internal piloting
E = External piloting

08

GRANDEZZA
08 = 8 mm
15 = 15 mm
SIZE
08 = 8 mm
15 = 15 mm

24

PRESSIONE
20 = 24 Bar
40 = 40 Bar
PRESSURE
20 = 24 Bar
40 = 40 Bar

VALVOLE DI PORTATA A REGOLAZIONE ELETTRONICA - FLOW CONTROL ELECTRONIC VALVE



TIPO A - A TYPE

| COD | DN DN | PORTA PORT | FLOW FLOW | 🛒 |
|--------|----------|---------------|--------------|---|
| 2 FCEV | 8 | 1/4" | 700 | 1 |
| 3 FCEV | 10 | 3/8" | 900 | 1 |
| 4 FCEV | 15 | 1/2" | 1800 | 1 |
| 5 FCEV | 20 | 3/4" | 2600 | 1 |
| 6 FCEV | 25 | 1" | 4000 | 1 |

MATERIALE: ACCIAIO INOX 316 L
MATERIAL: 316 L STAINLESS STEEL

DISPONIBILE A RICHIESTA:
IN OTTONE E NELLE VERSIONI A 3 VIE A "T" ED A "L"

AVAILABLE ON REQUEST:
BRASS AND 3 WAYS "T" AND "L" VERSIONS

TIPO B - A COMMUTAZIONE RAPIDA
B TYPE - FAST SWITCHING

| COD | DN DN | PORTA PORT | FLOW FLOW | 🛒 |
|----------|----------|---------------|--------------|---|
| 2 FCEV-R | 8 | 1/4" | 700 | 1 |
| 3 FCEV-R | 10 | 3/8" | 900 | 1 |
| 4 FCEV-R | 15 | 1/2" | 1800 | 1 |
| 5 FCEV-R | 20 | 3/4" | 2600 | 1 |
| 6 FCEV-R | 25 | 1" | 4000 | 1 |

MATERIALE: ACCIAIO INOX 316 L
MATERIAL: 316 L STAINLESS STEEL

DISPONIBILE A RICHIESTA:
IN OTTONE E NELLE VERSIONI A 3 VIE A "T" ED A "L"

AVAILABLE ON REQUEST:
BRASS AND 3 WAYS "T" AND "L" VERSIONS

| VOLTAGGIO VOLTAGE | CORRENTE DI LAVORO WORKING CURRENT | COPIA OUTPUT TORQUE | TEMPO COMMUTAZIONE TIME SWITCHING | SEGNALE DI CONTROLLO CONTROL MODE | PRESSIONE DI LAVORO WORKING PRESSURE | POTENZA POWER | TEMPERATURA DI ESERCIZIO WORKING TEMPERATURE | DIMENSIONI SIZES | GRADO IP IP GRADE | FUNZIONAMENTO OPERATION MODE |
|--------------------------------|---|-------------------------------|--|--|---|-------------------------|---|-------------------------------|---------------------------|--|
| TIPO A A TYPE DC 12÷24 V | TIPO A A TYPE < 200 mA | TIPO A A TYPE Max 10 Nm | TIPO A A TYPE 30 s | TIPO A A TYPE 4-20 mA | TIPO A A TYPE Max 10 Bar | TIPO A A TYPE 5 W | TIPO A A TYPE 0 ÷ 90 °C | TIPO A A TYPE DN 8 - 32 | TIPO A A TYPE IP 65 | TIPO A - A TYPE Automatic / Manuale Automatic mode / Manual mode |
| TIPO B B TYPE DC 12÷24 V | TIPO B B TYPE < 200 mA | TIPO B B TYPE Max 10 Nm | TIPO B B TYPE 5 s | TIPO B B TYPE 4-20 mA | TIPO B B TYPE Max 10 Bar | TIPO B B TYPE 5 W | TIPO B B TYPE 0 ÷ 90 °C | TIPO B B TYPE DN 8 - 32 | TIPO B B TYPE IP 65 | TIPO B - B TYPE Automatic / Manuale Automatic mode / Manual mode |

- Design semplice, dimensioni compatte, regolazione 4-20mA, è il prodotto intermedio che unisce valvole civili e industriali.
- Lo schermo LCD dello stato di funzionamento del prodotto è visibile e ha funzioni di controllo manuale ed elettrico.
- Adotta una trasmissione a ingranaggi interamente in metallo, con una coppia di uscita dalle prestazioni affidabili, fino a 10 Nm.
- Adotta il doppio limite di posizionamento elettrico e meccanico, accurato e alta efficienza.
- La connessione dell'attuatore alla valvola è conforme alla ISO 5211. Flangia di accoppiamento in grado di utilizzare diverse dimensioni di valvole.
- La valvola a sfera adotta la struttura a tenuta flottante, nessuna perdita di caduta, adatta a sporco pesante e lungo periodo di inattività.
- Buone prestazioni di tenuta, il grado di protezione è IP65.
- È possibile l'utilizzo come comando on/off.

- Simple design, compact size, 4-20mA adjustment, is the intermediate product connecting civil and industrial valves.
- The product running state LCD screen is visible and has manual and electric control functions.
- Adopt all-metal gear transmission, with reliable performance output torque, up to 10 Nm.
- Adopt double limit of electrical and mechanical, accurate positioning and high consistency.
- The connection between the actuator and the valve is ISO 5211 standard, and the flange type is F03 and F05, which is convenient for the user to match the valve body.
- The ball valve adopts the floating seal structure, no drop leakage, which is suitable for heavy dirt and long period of no action.
- Good sealing performance, the protection grade is IP65.
- It's possible to use like on/off command.

PRESSOSTATI E MANOMETRI DIGITALI - DIGITAL PRESSURE SWITCHES & PRESSURE GAUGES

PRESSOSTATI DIGITALI - DIGITAL PRESSURE SWITCHES

|  | COD | ATTACCO BSPP INLET | USCITE DIGITALI DIGITAL OUTPUTS | USCITE ANALOGICHE ANALOGIC OUTPUTS | SCALA RANGE | LUNGHEZZA CAVO CABLE LENGHT | Pin |
|---|----------|-----------------------|------------------------------------|---------------------------------------|----------------|--------------------------------|-----|
| | PD-010-P | 1/8" | 2 PNP | 1-5 VDC | 0+10 Bar | 2 mt | 1 |
| PD-030-P | 1/8" | 2 PNP | 1-5 VDC | 0+10 Bar | 2 mt | 1 | |
| PD-011-P | 1/8" | 2 PNP | 4-20 mA | 0+10 Bar | 2 mt | 1 | |
| PD-031-P | 1/8" | 2 PNP | 4-20 mA | 0+10 Bar | 2 mt | 1 | |
| PD-010-C | 1/8" | 2 PNP | 1-5 VDC | -1+1 Bar | 2 mt | 1 | |
| PD-030-C | 1/8" | 2 PNP | 1-5 VDC | -1+1 Bar | 2 mt | 1 | |
| PD-011-C | 1/8" | 2 PNP | 4-20 mA | -1+1 Bar | 2 mt | 1 | |
| PD-031-C | 1/8" | 2 PNP | 4-20 mA | -1+1 Bar | 2 mt | 1 | |
| PD-010-V | 1/8" | 2 PNP | 1-5 VDC | -1+0 Bar | 2 mt | 1 | |
| PD-030-V | 1/8" | 2 PNP | 1-5 VDC | -1+0 Bar | 2 mt | 1 | |
| PD-011-V | 1/8" | 2 PNP | 4-20 mA | -1+0 Bar | 2 mt | 1 | |
| PD-031-V | 1/8" | 2 PNP | 4-20 mA | -1+0 Bar | 2 mt | 1 | |

P = POSITIVO - POSITIVE
N = NEGATIVO - NEGATIVE

DATI TECNICI:

Temperatura di esercizio: max 50 °C
Gamma di pressioni (a seconda del modello): -1 + + 10 Bar
Tolleranza a 25 °C: ± 2%

TECHNICAL DATA:

Operating temperature: max 50 °C
Pressure range (depending on the model): -1 + + 10 Bar
Tolerance at 25 °C: ± 2%

SPECIFICHE TECNICHE:

Tensione di alimentazione: da 12 VDC A 24 VDC ± 10%
2 uscite digitali: NPN oppure PNP
Uscite Analogiche: 4 - 20 mA oppure 1 - 5 VDC
Connessione: Cavo 2 mt
Risoluzione strumento: Kpa, Mpa, Kgt/cm2, Bar, Psi, InHg
Grado di protezione: IP 65

APPLICAZIONI:

Fluidi: Aria, gas non corrosivi e incombustibili

TECHNICAL SPECIFICATIONS:

Voltage: 12 + 24 VDC ± 10%
2 Digital output: NPN or PNP
Analogic outputs: 4 - 20 mA or 1 - 5 VDC
Connection: 2 mt cable
Instrument resolution: Kpa, Mpa, Kgt/cm2, Bar, Psi, InHg
Protection degree: IP 65

APPLICATIONS:

Fluids: Air, non corrosive and incombustible gases

MANOMETRI DIGITALI - DIGITAL PRESSURE GAUGES

|  | COD | SCALA INLET | LUNGHEZZA CAVO CABLE LENGHT | ALIMENTAZIONE POWER SUPPLY | 🛒 |
|---|----------|----------------|---|---|---|
| | MD 60 P | 0+10 Bar | // | Batteria al Litio CR 2032 - Lithium Battery CR 2032 | 1 |
| MD 60 V | -1+0 Bar | // | Batteria al Litio CR 2032 - Lithium Battery CR 2032 | 1 | |
| MD 61 P | 0+10 Bar | 2 mt | 12 + 24 Vdc | 1 | |
| MD 61 V | -1+0 Bar | 2 mt | 12 + 24 Vdc | 1 | |

* PREZZO A RICHIESTA
PRICE ON REQUEST

DATI TECNICI

Temperatura di esercizio: max 50 °C
Gamma di pressioni (a seconda del modello): -1 + + 10 Bar
Tolleranza a 25 °C: ± 2%

TECHNICAL DATA:

Operating temperature: max 50 °C
Pressure range (depending on the model): -1 + + 10 Bar
Tolerance at 25 °C: ± 2%

SPECIFICHE TECNICHE:

Tensione di alimentazione: da 12 VDC A 24 VDC ± 10%
Connessione: CAVO 2 mt
Risoluzione strumento: Kpa, Mpa, Kgt/cm2, Bar, Psi
Grado di protezione: IP 65

TECHNICAL SPECIFICATIONS:

Voltage: 12 + 24 VDC ± 10%
Connection: 2 mt cable
Instrument resolution: Kpa, Mpa, Kgt/cm2, Bar, Psi
Protection degree: IP 65

APPLICAZIONI:

Fluidi: Aria, gas non corrosivi e incombustibili

APPLICATIONS:

Fluids: Air, non corrosive and incombustible gases

ACCESSORI PER IL MONTAGGIO - MOUNTING ACCESSORIES

PRESSOSTATO - PRESSURE SWITCH

| COD | DESCRIZIONE - DESCRIPTION |
|------|---|
| SP-A | STAFFA PER FISSAGGIO A PARETE - WALL FIXING BRACKET |
| SP-B | STAFFA PER FISSAGGIO A PAVIMENTO - FLOOR FIXING BRACKET |
| SP-C | ADATTATORE PER FISSAGGIO A PANNELLO COMPLETO DI PROTEZIONE ADAPTER FOR PANEL MOUNTING (PROTECTION INCLUDED) |

MANOMETRO - PRESSURE GAUGE

| COD | DESCRIZIONE - DESCRIPTION |
|------|---|
| FM-A | CONNETTORE FEMMINA M8 - Cavo 2mt 4 pin FEMALE CONNECTOR M8 - 2mt Cavo (4 pin) |
| FM-B | STAFFA PER FISSAGGIO A PARETE - WALL FIXING BRACKET |
| FM-C | STAFFA PER FISSAGGIO A PAVIMENTO - FLOOR FIXING BRACKET |



Per maggiori chiarimenti e specifiche consultare il relativo Fascicolo Tecnico.
For further clarifications and specifications, consult the relevant Technical File.



SOLENOID & MANUAL VALVES

| | | | | | |
|---|--|-----|--|---|-----|
|  | MONOSTABILE 5/2 5/2 SINGLE SOLENOID VALVES | 203 |  | CONNETTORI CONNECTORS | 207 |
|  | BISTABILE 5/2 5/2 DOUBLE SOLENOID VALVES | 203 |  | BOBINE STANDARD STANDARD COILS | 207 |
|  | BISTABILE 5/3 5/3 DOUBLE SOLENOID VALVES | 203 |  | MONOSTABILE 5/2 5/2 SINGLE SOLENOID VALVES | 208 |
|  | MONOSTABILE NAMUR NAMUR SINGLE SOLENOID VALVES | 203 |  | BISTABILE 5/2 5/2 DOUBLE SOLENOID VALVES | 208 |
|  | BISTABILE NAMUR NAMUR DOUBLE SOLENOID VALVES | 203 |  | MONOSTABILE NAMUR NAMUR 5/2 SINGLE COIL VALVES | 208 |
|  | REGOLATORI DI FLUSSO PER VALVOLE NAMUR FLOW REGULATORS FOR NAMUR VALVES | 204 |  | BISTABILE NAMUR NAMUR 5/2 DOUBLE COIL VALVES | 208 |
|  | MONOSTABILE 5/2 5/2 SINGLE SOLENOID VALVES CERAMIC SPOOL | 206 |  | SOTTOBASI MANIFOLD PER VALVOLE SERIE 4V MANIFOLD TYPE SUB-BASES FOR SERIES 4V VALVES | 209 |
|  | BISTABILE 5/2 5/2 DOUBLE SOLENOID VALVES CERAMIC SPOOL | 206 |  | A SIC. INTRINSECA MONOSTABILE 5/2 INTRINSICALLY SAFE VALVES | 209 |
|  | BISTABILE 5/3 5/3 DOUBLE SOLENOID VALVES CERAMIC SPOOL | 206 |  | A SIC. INTRINSECA BISTABILE 5/2 INTRINSICALLY SAFE VALVES | 209 |
|  | SOTTOBASE SUB-BASE | 206 |  | A SICUREZZA INTRINSECA MONOSTABILE 5/2 NAMUR INTRINSICALLY SAFE VALVES NAMUR 5/2 SINGLE COIL VALVES | 209 |
|  | SOTTOBASE MODULARE MODULAR SUB-BASE | 206 |  | A SICUREZZA INTRINSECA BISTABILE 5/2 NAMUR INTRINSICALLY SAFE VALVES NAMUR 5/2 DOUBLE COIL VALVES | 209 |
|  | BOBINE ATEX - UL ATEX - UL COILS | 207 |  | VALVOLA TIGER MONOSTABILE SINGLE SOLENOID VALVE "TIGER" TYPE | 210 |

| | | | | | |
|---|---|-----|---|--|-----|
|  | VALVOLA TIGER BISTABILE DOUBLE SOLENOID VALVE "TIGER" TYPE | 211 |  | SMOV 01 | 214 |
|  | VALVOLA A COM. PNEUM. MONOSTABILE 5/2 5/2 SINGLE PNEUMATIC PILOT VALES | 212 |  | SMOV 02 | 214 |
|  | VALVOLA A COM. PNEUM. BISTABILE 5/2 5/2 DOUBLE PNEUMATIC PILOT VALES | 212 |  | SMOV 03 | 214 |
|  | VALVOLA A COM. PNEUM. BISTABILE 5/3 5/3 DOUBLE PNEUMATIC PILOT VALES | 212 |  | SMOV 04 | 214 |
|  | LEVA A 90° 90° LEVER | 212 |  | SMSV 321 PB SMSV 322 PB SMSV 521 PB SMSV 522 PB | 215 |
|  | LEVA A TIRO PULL LEVER | 212 |  | SMSV 321 PP SMSV 322 PP SMSV 521 PP SMSV 522 PP | 215 |
|  | SDK | 213 |  | SMSV 321 EB SMSV 322 EB SMSV 521 EB SMSV 522 EB | 215 |
|  | SHV | 213 |  | SMSV 321 PPL SMSV 322 PPL SMSV 521 PPL SMSV 522 PPL | 215 |
|  | SHV | 213 |  | SMSV 321 SMSV 322 SMSV 521 SMSV 522 | 215 |
|  | SJM 05 | 214 |  | SMSV 321 R SMSV 322 R SMSV 521 R SMSV 522 R | 215 |
|  | SJM 06 | 214 |  | SMSV 321 TB SMSV 322 TB SMSV 521 TB SMSV 522 TB | 215 |
|  | SJM 06 A | 214 |  | SMSV 321 LB SMSV 322 LB SMSV 521 LB SMSV 522 LB | 215 |
|  | SJM 07 | 214 |  | VP4F - VP4FM - VPFV VP4F - VP4FM - VPFV | 216 |

ELETTROVALVOLE E VALVOLE MANUALI - SOLENOID AND MANUAL VALVES

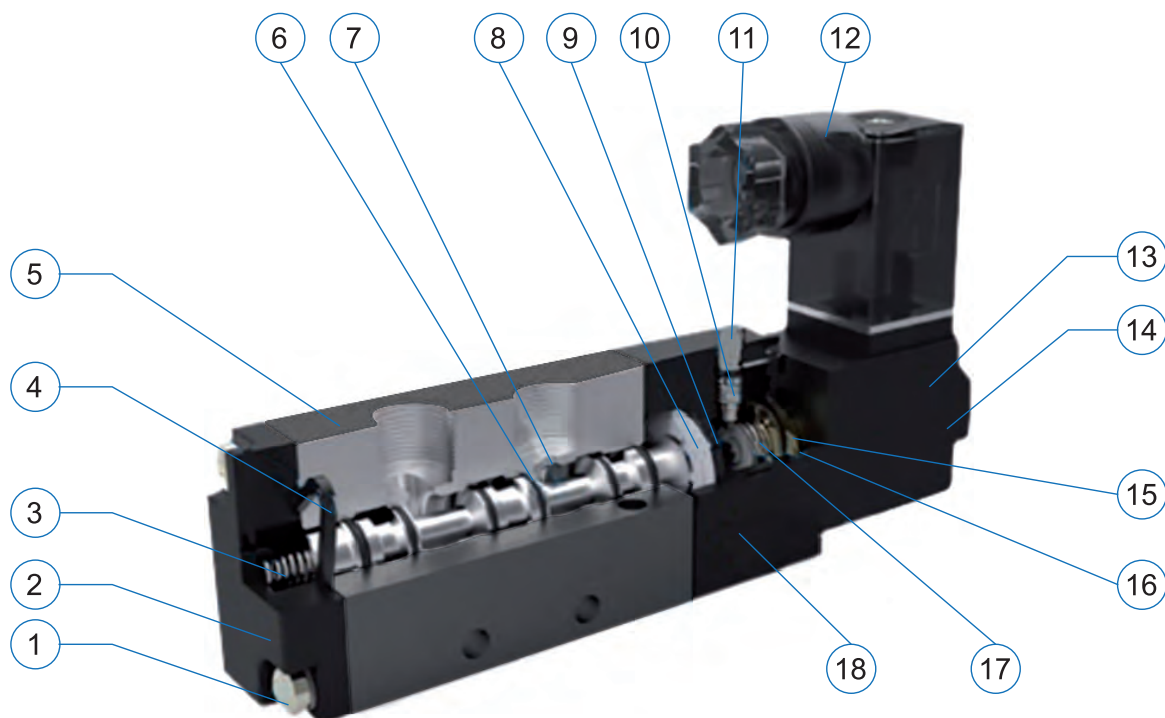

| POSIZIONE POSITION | DENOMINAZIONE | DESCRIPTION | POSIZIONE POSITION | DENOMINAZIONE | DESCRIPTION |
|-----------------------|-------------------|----------------|-----------------------|-----------------------|-------------------|
| 1 | VITE DI FISSAGGIO | FIXING SCREW | 10 | MOLLA OTTURATORE | SHUTTER SPRING |
| 2 | COPERCHIO | COVER | 11 | COMANDO MANUALE | MANUAL CONTROL |
| 3 | MOLLA | SPRING | 12 | CONNETTORE | CONNECTOR |
| 4 | TENUTA POSTERIORE | REAR SEAL | 13 | BOBINA | COIL |
| 5 | CORPO VALVOLA | VALVE BODY | 14 | VITA FISSAGGIO BOBINA | FIXING COIL SCREW |
| 6 | O-RING SPOLA | O-RING SHUTTLE | 15 | BASE BOBINA | COIL BASE |
| 7 | SPOLA | SHUTTLE | 16 | TENUTA BOBINA | COIL SEAL |
| 8 | OTTURATORE PILOTA | PILOT SHUTTER | 17 | DISTANZIALE | SPACER |
| 9 | TENUTA OTTURATORE | SHUTTER SEAL | 18 | PILOTAGGIO VALVOLA | VALVE PILOTING |



COLORE NERO: STANDARD
COLORE BIANCO: A RICHIESTA



BLACK COLOR: STANDARD
WHITE COLOUR: ON REQUEST

MONOSTABILE 5/2 - 5/2 SINGLE SOLENOID VALVES

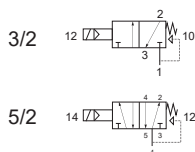

| COD |
|----------|
| 4V110-M5 |
| 4V110-06 |
| 4V210-06 |
| 4V210-08 |
| 4V310-08 |
| 4V310-10 |
| 4V410-15 |

| CARATTERISTICHE - FEATURES |
|--|
| 5/2 pilotaggio interno 5/2 Internal Pilot |
| A RICHIESTA: 3/2 3/2: ON REQUEST |

| DIMENSIONI - SIZES | |
|--------------------|---|
| M5 | 1 |
| 1/8" (P) | 1 |
| 1/8" (G) | 1 |
| 1/4" (P) | 1 |
| 1/4" (G) | 1 |
| 3/8" | 1 |
| 1/2" | 1 |

BISTABILE 5/2 - 5/2 DOUBLE SOLENOID VALVES

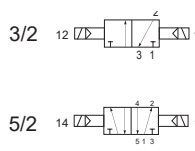

| COD |
|----------|
| 4V120-M5 |
| 4V120-06 |
| 4V220-06 |
| 4V220-08 |
| 4V320-08 |
| 4V320-10 |
| 4V420-15 |

| CARATTERISTICHE - FEATURES |
|--|
| 5/2 pilotaggio interno 5/2 Internal Pilot |
| A RICHIESTA: 3/2 3/2: ON REQUEST |

| DIMENSIONI - SIZES | |
|--------------------|---|
| M5 | 1 |
| 1/8" (P) | 1 |
| 1/8" (G) | 1 |
| 1/4" (P) | 1 |
| 1/4" (G) | 1 |
| 3/8" | 1 |
| 1/2" | 1 |

BISTABILE 5/3 - 5/3 DOUBLE SOLENOID VALVES

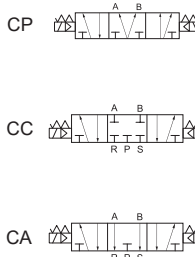

| COD |
|----------|
| 4V130-M5 |
| 4V130-06 |
| 4V230-08 |
| 4V330-10 |
| 4V430-15 |
| 4V140-M5 |
| 4V140-06 |
| 4V240-08 |
| 4V340-10 |
| 4V440-15 |
| 4V150-M5 |
| 4V150-06 |
| 4V250-08 |
| 4V350-10 |
| 4V450-15 |

| CARATTERISTICHE - FEATURES |
|--|
| CENTRI CHIUSI - CLOSED CENTERS |
| CENTRI CHIUSI - CLOSED CENTERS |
| CENTRI CHIUSI - CLOSED CENTERS |
| CENTRI CHIUSI - CLOSED CENTERS |
| CENTRI CHIUSI - CLOSED CENTERS |
| CENTRI IN PRESSIONE - PRESSURE CENTERS |
| CENTRI IN PRESSIONE - PRESSURE CENTERS |
| CENTRI IN PRESSIONE - PRESSURE CENTERS |
| CENTRI IN PRESSIONE - PRESSURE CENTERS |
| CENTRI IN PRESSIONE - PRESSURE CENTERS |
| CENTRI APERTI - EXHAUST CENTERS |
| CENTRI APERTI - EXHAUST CENTERS |
| CENTRI APERTI - EXHAUST CENTERS |
| CENTRI APERTI - EXHAUST CENTERS |
| CENTRI APERTI - EXHAUST CENTERS |

| DIMENSIONI - SIZES | |
|--------------------|---|
| M5 | 1 |
| 1/8" | 1 |
| 1/4" | 1 |
| 3/8" | 1 |
| 1/2" | 1 |
| M5 | 1 |
| 1/8" | 1 |
| 1/4" | 1 |
| 3/8" | 1 |
| 1/2" | 1 |
| M5 | 1 |
| 1/8" | 1 |
| 1/4" | 1 |
| 3/8" | 1 |
| 1/2" | 1 |

MONOSTABILE NAMUR - NAMUR SINGLE SOLENOID VALVES

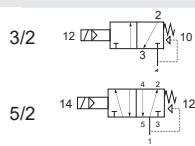

| COD |
|----------|
| 4M210-06 |
| 4M210-08 |
| 4M310-08 |
| 4M310-10 |
| 4M410-15 |

| CARATTERISTICHE - FEATURES |
|--|
| 5/2 pilotaggio interno 5/2 Internal Pilot |
| A RICHIESTA: 3/2 3/2: ON REQUEST |

| DIMENSIONI - SIZES | |
|--------------------|---|
| 1/8" | 1 |
| 1/4" (P) | 1 |
| 1/4" (G) | 1 |
| 3/8" | 1 |
| 1/2" | 1 |

BISTABILE NAMUR - NAMUR DOUBLE SOLENOID VALVES

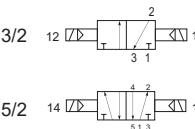

| COD |
|----------|
| 4M220-06 |
| 4M220-08 |
| 4M320-08 |
| 4M320-10 |
| 4M420-15 |

| CARATTERISTICHE - FEATURES |
|--|
| 5/2 pilotaggio interno 5/2 Internal Pilot |
| A RICHIESTA: 3/2 3/2: ON REQUEST |

| DIMENSIONI - SIZES | |
|--------------------|---|
| 1/8" | 1 |
| 1/4" (P) | 1 |
| 1/4" (G) | 1 |
| 3/8" | 1 |
| 1/2" | 1 |

LE ELETTROVALVOLE VENGONO FORNITE SENZA BOBINA. IL PREZZO DELLA BOBINA VIENE COMUNICATO A PARTE.
 VOLTAGGI DISPONIBILI: DC 12V - DC 24V - AC 24V - AC 110V - AC 220V - AC 380V IL VOLTAGGIO È DA SPECIFICARE IN FASE DI ORDINE.
 THE SOLENOID VALVES ARE SUPPLIED WITHOUT COIL. COIL PRICE IS COMMUNICATED SEPARATELY.
 VOLTAGES AVAILABLE: DC 12V - DC 24V - AC 24V - AC 110V - AC 220V - AC 380V. THE VOLTAGE IS TO BE SPECIFIED WHEN ORDERING.

ELETTROVALVOLE A BASSA TEMPERATURA: DISPONIBILI A RICHIESTA - LOW TEMPERATURE SOLENOID VALVE AVAILABLE ON REQUEST.

Cod. M 60025



Cod. M 61025

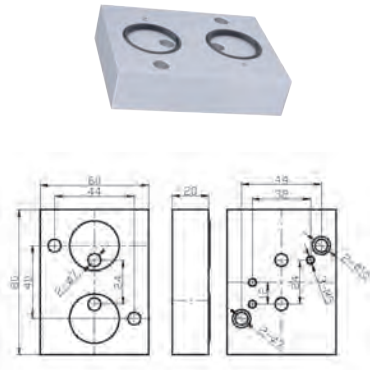

Cod. M 62025

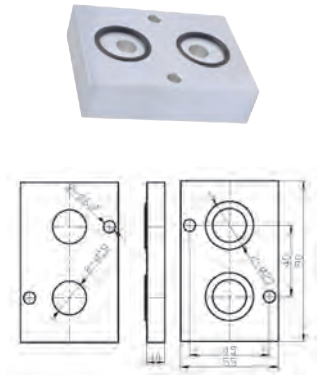

Cod. M 010023

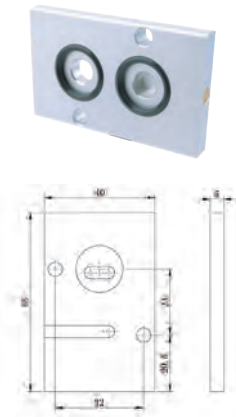

Cod. M 010025

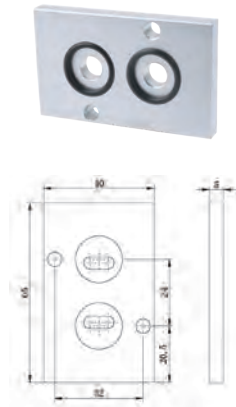

Cod. M 020025

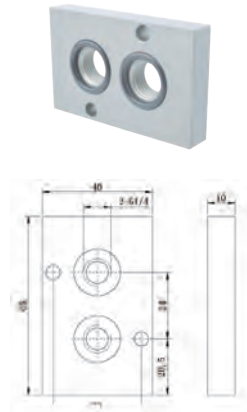

Cod. M 010746

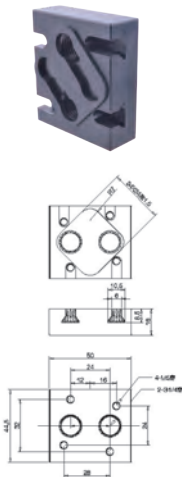

Cod. MT 040025

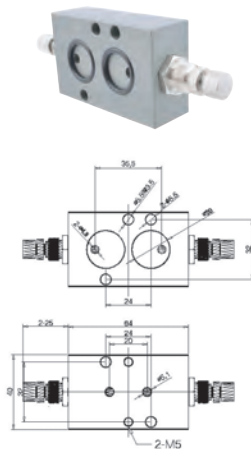

Cod. MT 040023

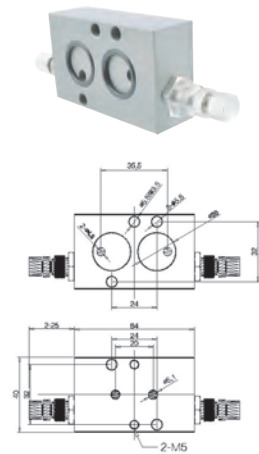

SCHEMA DI MONTAGGIO - *ASSEMBLY DIAGRAM*

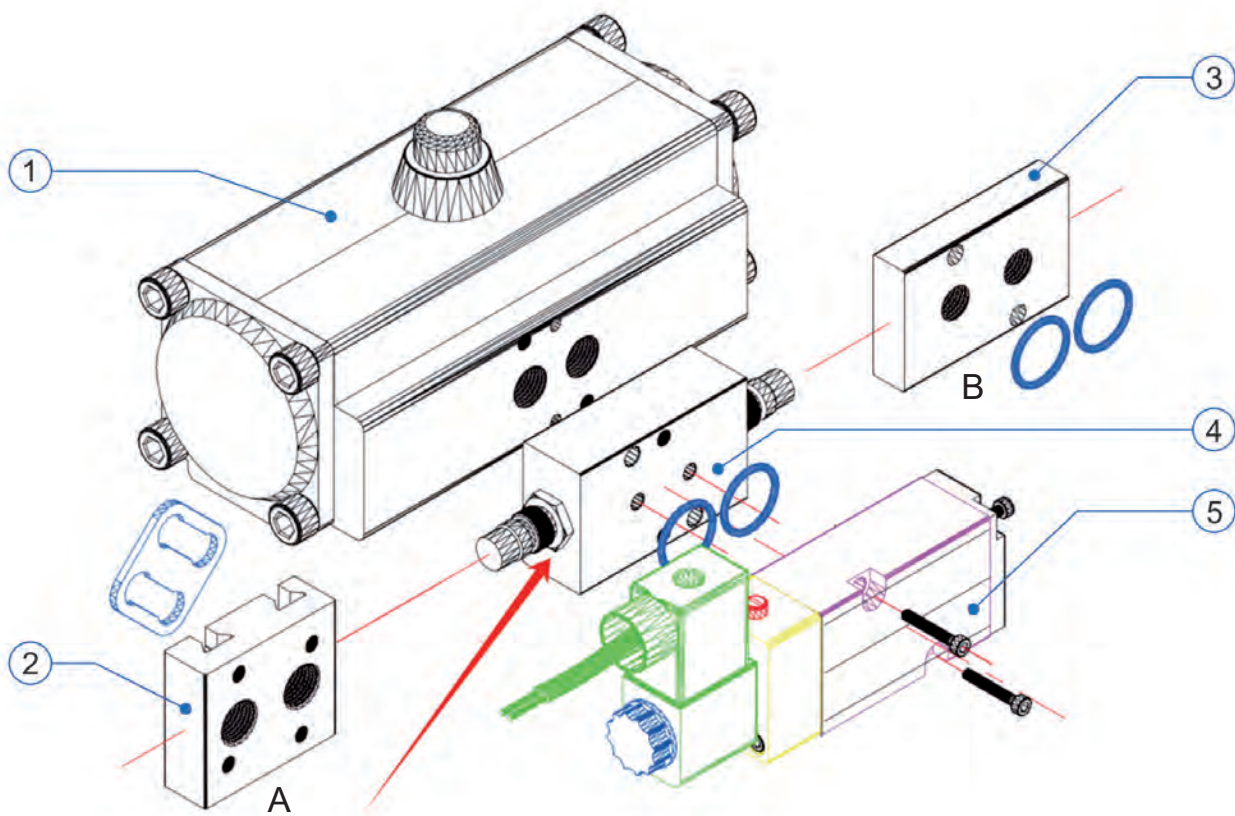

| | DESCRIZIONE | DESCRIPTION |
|---|----------------------|---------------------------|
| 1 | Attuatore Pneumatico | <i>Pneumatic Actuator</i> |
| 2 | Sottobase tipo A | <i>Sub Base A Type</i> |
| 3 | Sottobase tipo B | <i>Sub Base B Type</i> |
| 4 | Regolatore di flusso | <i>Flow Regulator</i> |
| 5 | Valvola Namur | <i>Namur Valve</i> |

Il regolatore di flusso bidirezionale NAMUR viene montato sull'attuatore a sandwich mediante le basette offerte in opzione. Può essere posizionato alla distanza desiderata e, con la basetta per il montaggio a coda di rondine, può essere equipaggiato di ulteriori accessori.
 Può essere 3 vie o 5 vie a seconda dell'esigenza di movimentazione dell'attuatore.

The NAMUR two-way flow regulator is mounted on the sandwich actuator and by means of the optioned sideburns can be placed at the desired distance and with the dovetail mounting board can be equipped with additional accessories. It can be 3-way or 5-way depending on the handling requirement.

MONOSTABILE 5/2 - 5/2 SINGLE SOLENOID VALVES



Ceramic Spool

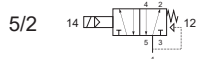

| COD |
|----------|
| SK19114M |
| SK29114M |
| SK39114M |

CARATTERISTICHE - FEATURES
 5/2 pilotaggio interno / esterno elettrico / pneumatico
cassetti in ceramica
 5/2 internal / external electrical / pneumatic pilot
ceramic spool

| DIMENSIONI - SIZES | |
|--------------------|---|
| ISO 1 | 1 |
| ISO 2 | 1 |
| ISO 3 | 1 |

BISTABILE 5/2 - 5/2 DOUBLE SOLENOID VALVES



Ceramic Spool

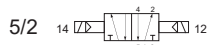

| COD |
|-----------|
| SK191124M |
| SK291124M |
| SK391124M |

CARATTERISTICHE - FEATURES
 5/2 pilotaggio interno / esterno elettrico / pneumatico
cassetti in ceramica
 5/2 internal / external electrical / pneumatic pilot
ceramic spool

| DIMENSIONI - SIZES | |
|--------------------|---|
| ISO 1 | 1 |
| ISO 2 | 1 |
| ISO 3 | 1 |

BISTABILE 5/3 - 5/3 DOUBLE SOLENOID VALVES



Ceramic Spool

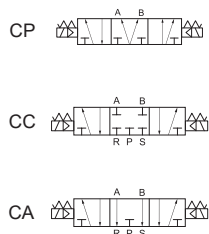

| COD |
|----------|
| SK19134M |
| SK29134M |
| SK39134M |
| SK19144M |
| SK29144M |
| SK39144M |
| SK19154M |
| SK29154M |
| SK39154M |

CARATTERISTICHE - FEATURES
 5/2 pilotaggio interno / esterno elettrico / pneumatico
cassetti in ceramica
 5/2 internal / external electrical / pneumatic pilot
ceramic spool

| DIMENSIONI - SIZES | |
|--------------------|---|
| ISO 1 | 1 |
| ISO 2 | 1 |
| ISO 3 | 1 |
| ISO 1 | 1 |
| ISO 2 | 1 |
| ISO 3 | 1 |
| ISO 1 | 1 |
| ISO 2 | 1 |
| ISO 2 | 1 |

SOTTOBASE - SUB-BASE



| COD |
|-------|
| 19702 |
| 29702 |
| 39703 |

CARATTERISTICHE - FEATURES
 sottobase singola
single sub-base

| DIMENSIONI - SIZES | |
|--------------------|---|
| ISO 1 | 1 |
| ISO 1 | 1 |
| ISO 1 | 1 |

SOTTOBASE MODULARE - MODULAR SUB-BASE



| COD |
|-------|
| 19902 |
| 19906 |
| 29902 |
| 29906 |
| 39902 |
| 39906 |

CARATTERISTICHE - FEATURES
 sottobase manifold - manifold sub-base
 chiusura End Plate - End Plate closure

| DIMENSIONI - SIZES | |
|--------------------|---|
| ISO 1 | 1 |
| ISO 1 | 1 |
| ISO 2 | 1 |
| ISO 2 | 1 |
| ISO 3 | 1 |
| ISO 3 | 1 |

COME ORDINARE

| | | | | |
|--------------------------|--|---|--------------------|---|
| SK | 19 | 114 | M | TF |
| SPEED KING ISO 5599/1 | ISO 1 = 19 ISO 2 = 29 ISO 3 = 39 | PN = 104 MONO = 114 BISTABILE = 124 5/3 CC = 134 5/3 CP = 144 5/3 CA = 154 | COMANDO MANUALE | TF = 24 V DC - 48 V AC S = 60 V DC - 110 AC TL = 110 V DC - 220 AC // = PNEUMATICA TA = 12 V DC - 24 V AC |

HOW TO ORDER

| | | | | |
|--------------------------|--|---|-------------------|--|
| SK | 19 | 114 | M | TF |
| SPEED KING ISO 5599/1 | ISO 1 = 19 ISO 2 = 29 ISO 3 = 39 | PN = 104 MONO = 114 BISTABILE = 124 5/3 CC = 134 5/3 CP = 144 5/3 CA = 154 | MANUAL COMMAND | TF = 24 V DC - 48 V AC S = 60 V DC - 110 AC TL = 110 V DC - 220 AC // = PNEUMATIC TA = 12 V DC - 24 V AC |

BOBINE ATEX - UL - ATEX - UL COILS

| | COD | CARATTERISTICHE FEATURES | 🛒 |
|---|----------|--|----|
|  | BAX-ATEX | Tutti i voltaggi All voltages | 10 |
| | BAX - UL | Disponibile 24 DC Available 24 DC | 10 |
| | BAX-C | Tutti i voltaggi + cavo lungh. 300 mm. All voltages + cable length. 300 mm. | 10 |

CONNETTORI - CONNECTORS

| | COD | CARATTERISTICHE FEATURES | 🛒 |
|---|-----|-------------------------------------|----|
|  | CA | Con pressa cavo With cable gland | 10 |

BOBINE STANDARD - STANDARD COILS

| | COD | CARATTERISTICHE - FEATURES | DIMENSIONI - SIZES | 🛒 |
|---|-----------|----------------------------|--------------------|----|
|  | BA-12 DC | V 12 DC - DC 5,5 W | 22 mm | 10 |
| | BA-24 DC | V 24 DC - DC 5,5 W | 22 mm | 10 |
| | BA-24 AC | V 24 AC - AC 5,5 W | 22 mm | 10 |
| | BA-110 AC | V 110 AC - AC 5,5 W | 22 mm | 10 |
| | BA-220 AC | V 220 AC - AC 5,5 W | 22 mm | 10 |
| | BA-380 AC | V 380 AC - AC 5,5 W | 22 mm | 10 |

VOLTAGGI DISPONIBILI: DC 12V - DC 24V - AC 24 V - AC 110 V - AC 220 V - AC 380 V - IL VOLTAGGIO È DA SPECIFICARE IN FASE DI ORDINE.
 VOLTAGES AVAILABLE: DC 12V - DC 24V - AC 24 V - AC 110 V - AC 220 V - AC 380 V - THE VOLTAGE IS TO BE SPECIFIED WHEN ORDERING.

ELETTROVALVOLE E VALVOLE MANUALI - SOLENOID AND MANUAL VALVES

MONOSTABILE 5/2 - 5/2 STAINLESS STEEL SINGLE SOLENOID VALVES

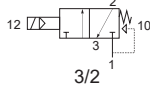
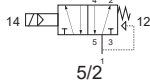
|  AISI 316 L |  3/2 |  5/2 | COD | CARATTERISTICHE - FEATURES | DIMENSIONI - SIZES | 🛒 |
|--|--|--|--|----------------------------|--------------------|---|
| | | | 4V110-M5-X | M5 | 1 | |
| 4V110-06-X | 1/8" (P) | 1 | 5/2 pilotaggio interno 5/2 Internal Pilot | 1/8" (P) | 1 | |
| 4V210-06-X | 1/8" (G) | 1 | A RICHIESTA: 3/2 3/2: ON REQUEST | 1/4" (P) | 1 | |
| 4V210-08-X | 1/4" (P) | 1 | | | | |
| 4V310-08-X | 1/4" (G) | 1 | 3/8" | 1 | | |
| 4V310-10-X | 3/8" | 1 | 1/2" | 1 | | |
| 4V410-15-X | 1/2" | 1 | | | | |

BISTABILE 5/2 - 5/2 STAINLESS STEEL DOUBLE SOLENOID VALVES

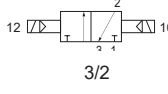
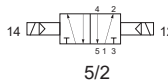
|  AISI 316 L |  3/2 |  5/2 | COD | CARATTERISTICHE - FEATURES | DIMENSIONI - SIZES | 🛒 |
|--|--|--|--|----------------------------|--------------------|---|
| | | | 4V120-M5-X | M5 | 1 | |
| 4V120-06-X | 1/8" (P) | 1 | 5/2 pilotaggio interno 5/2 Internal Pilot | 1/8" (P) | 1 | |
| 4V220-06-X | 1/8" (G) | 1 | A RICHIESTA: 3/2 3/2: ON REQUEST | 1/4" (P) | 1 | |
| 4V220-08-X | 1/4" (P) | 1 | | | | |
| 4V320-08-X | 1/4" (G) | 1 | 3/8" | 1 | | |
| 4V320-10-X | 3/8" | 1 | 1/2" | 1 | | |
| 4V420-15-X | 1/2" | 1 | | | | |

MONOSTABILE NAMUR - NAMUR 5/2 STAINLESS STEEL SINGLE COIL VALVES

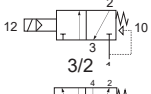
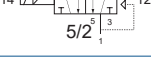
|  AISI 316 L |  3/2 |  5/2 | COD | CARATTERISTICHE - FEATURES | DIMENSIONI - SIZES | 🛒 |
|---|---|--|--|----------------------------|--------------------|---|
| | | | 4M210-06 | 1/8" | 1 | |
| 4M210-08 | 1/4" (P) | 1 | 5/2 pilotaggio interno 5/2 Internal Pilot | 1/4" (P) | 1 | |
| 4M310-08 | 1/4" (G) | 1 | A RICHIESTA: 3/2 3/2: ON REQUEST | 3/8" | 1 | |
| 4M310-10 | 3/8" | 1 | | | | |
| 4M410-15 | 1/2" | 1 | | | | |

BISTABILE NAMUR - NAMUR 5/2 STAINLESS STEEL DOUBLE COIL VALVES

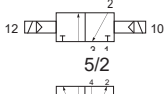
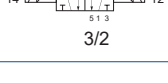
|  AISI 316 L |  5/2 |  3/2 | COD | CARATTERISTICHE - FEATURES | DIMENSIONI - SIZES | 🛒 |
|--|--|--|--|----------------------------|--------------------|---|
| | | | 4M220-06 | 1/8" | 1 | |
| 4M220-08 | 1/4" (P) | 1 | 5/2 pilotaggio interno 5/2 Internal Pilot | 1/4" (P) | 1 | |
| 4M320-08 | 1/4" (G) | 1 | A RICHIESTA: 3/2 3/2: ON REQUEST | 3/8" | 1 | |
| 4M320-10 | 3/8" | 1 | | | | |
| 4M420-15 | 1/2" | 1 | | | | |

BOBINE ATEX - UL - ATEX - UL COILS

| COD | CARATTERISTICHE FEATURES | 🛒 |
|----------|--|----|
| BAX-ATEX | Tutti i voltaggi All voltages | 10 |
| BAX - UL | Disponibile 24 DC Available 24 DC | 10 |
| BAX-C | Tutti i voltaggi + cavo lungh. 300 mm. All voltages + cable length. 300 mm. | 10 |

CONNETTORI - CONNECTORS

| COD | CARATTERISTICHE FEATURES | 🛒 |
|-----|-------------------------------------|----|
| CA | Con pressa cavo With cable gland | 10 |

BOBINE STANDARD - STANDARD COILS

| COD | CARATTERISTICHE - FEATURES | DIMENSIONI - SIZES | 🛒 |
|-----------|----------------------------|--------------------|----|
| BA-12 DC | V 12 DC - DC 5,5 W | 22 mm | 10 |
| BA-24 DC | V 24 DC - DC 5,5 W | 22 mm | 10 |
| BA-24 AC | V 24 AC - AC 5,5 W | 22 mm | 10 |
| BA-110 AC | V 110 AC - AC 5,5 W | 22 mm | 10 |
| BA-220 AC | V 220 AC - AC 5,5 W | 22 mm | 10 |
| BA-380 AC | V 380 AC - AC 5,5 W | 22 mm | 10 |

VOLTAGGI DISPONIBILI: DC 12V - DC 24V - AC 24 V - AC 110 V - AC 220 V - AC 380 V - IL VOLTAGGIO È DA SPECIFICARE IN FASE DI ORDINE.
 VOLTAGES AVAILABLE: DC 12V - DC 24V - AC 24 V - AC 110 V - AC 220 V - AC 380 V - THE VOLTAGE IS TO BE SPECIFIED WHEN ORDERING.

SOTTOBASI TIPO MANIFOLD PER VALVOLE SERIE 4V - MANIFOLD TYPE SUB-BASES FOR SERIES 4V VALVES



| COD | DIMENSIONI SIZES | CARATTERISTICHE FEATURES | (*) DISPONIBILI PER POSIZIONI DA 1 A 6 ELETTROVALVOLE 5/2 A RICHIESTA PER ELETTROVALVOLE 3/2 IL PREZZO SI RIFERISCE ALLA SINGOLA POSIZIONE | 🛒 |
|-----------|---------------------|---|---|---|
| 100 M (*) | 1/8" | MANIFOLD PER SERIE 4V100 MANIFOLD FOR 4V100 SERIES | (*) AVAILABLE FOR POSITIONS FROM 1 TO 6 SOLENOID VALVES ON REQUEST FOR SOLENOID VALVES 3/2 THE PRICE REFERS TO SINGLE POSITION | 1 |
| 200 M (*) | 1/4" | MANIFOLD PER SERIE 4V200 MANIFOLD FOR 4V200 SERIES | | 1 |
| 300 M (*) | 3/8" | MANIFOLD PER SERIE 4V300 MANIFOLD FOR 4V300 SERIES | | 1 |
| 400 M (*) | 1/2" | MANIFOLD PER SERIE 4V400 MANIFOLD FOR 4V400 SERIES | | 1 |

ELETTROVALVOLE A SICUREZZA INTRINSECA - SOLENOID INTRINSICALLY SAFE VALVES

MONOSTABILE 5/2 - 5/2 SINGLE SOLENOID VALVES



ALLUMINIO
ALUMINIUM

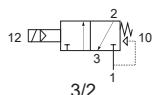

3/2

| COD | CARATTERISTICHE - FEATURES | DIMENSIONI - SIZES | 🛒 |
|-------------|--|--------------------|---|
| 4V-210-EX | 5/2 pilotaggio interno 5/2 Internal Pilot | 1/4" | 1 |
| 4V-210-X-EX | | 1/4" | 1 |

A RICHIESTA: 3/2
3/2: ON REQUEST



AISI 316 L
AISI 316 L

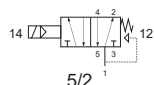

5/2

BISTABILE 5/2 - 5/2 DOUBLE SOLENOID VALVES



ALLUMINIO
ALUMINIUM

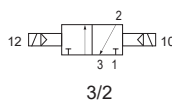

3/2

| COD | CARATTERISTICHE - FEATURES | DIMENSIONI - SIZES | 🛒 |
|-------------|--|--------------------|---|
| 4V-220-EX | 5/2 pilotaggio interno 5/2 Internal Pilot | 1/4" | 1 |
| 4V-220-X-EX | | 1/4" | 1 |

A RICHIESTA: 3/2
3/2: ON REQUEST



AISI 316 L
AISI 316 L

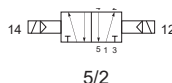

5/2

MONOSTABILE 5/2 NAMUR - NAMUR 5/2 SINGLE COIL VALVES



ALLUMINIO
ALUMINIUM

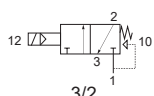

3/2

| COD | CARATTERISTICHE - FEATURES | DIMENSIONI - SIZES | 🛒 |
|-------------|--|--------------------|---|
| 4M-210-EX | 5/2 pilotaggio interno 5/2 Internal Pilot | 1/4" | 1 |
| 4M-210-X-EX | | 1/4" | 1 |

A RICHIESTA: 3/2
3/2: ON REQUEST



AISI 316 L
AISI 316 L

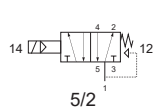

5/2

BISTABILE 5/2 NAMUR - NAMUR 5/2 DOUBLE COIL VALVES



ALLUMINIO
ALUMINIUM

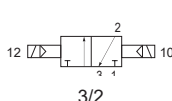

3/2

| COD | CARATTERISTICHE - FEATURES | DIMENSIONI - SIZES | 🛒 |
|-------------|--|--------------------|---|
| 4M-220-EX | 5/2 pilotaggio interno 5/2 Internal Pilot | 1/4" | 1 |
| 4M-220-X-EX | | 1/4" | 1 |

A RICHIESTA: 3/2
3/2: ON REQUEST



AISI 316 L
AISI 316 L

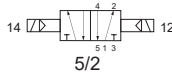

5/2

VALVOLA TIGER MONOSTABILE - *SINGLE SOLENOID VALVE "TIGER" TYPE*



| COD | CARATTERISTICHE - FEATURES | DIMENSIONI - SIZES | 🛒 |
|----------|---|--------------------|---|
| 1 SMFH | | 1/8" | 1 |
| 1 SMFH-S | 5/2 PILOTAGGIO INTERNO ED ESTERNO | 1/8" | 1 |
| 2 SMFH | | 1/4" | 1 |
| 2 SMFH-S | 5/2 INTERNAL AND EXTERNAL PILOT | 1/4" | 1 |
| 3 SMFH | | 1/2" | 1 |
| 4 SMFH-S | | 1/2" | 1 |

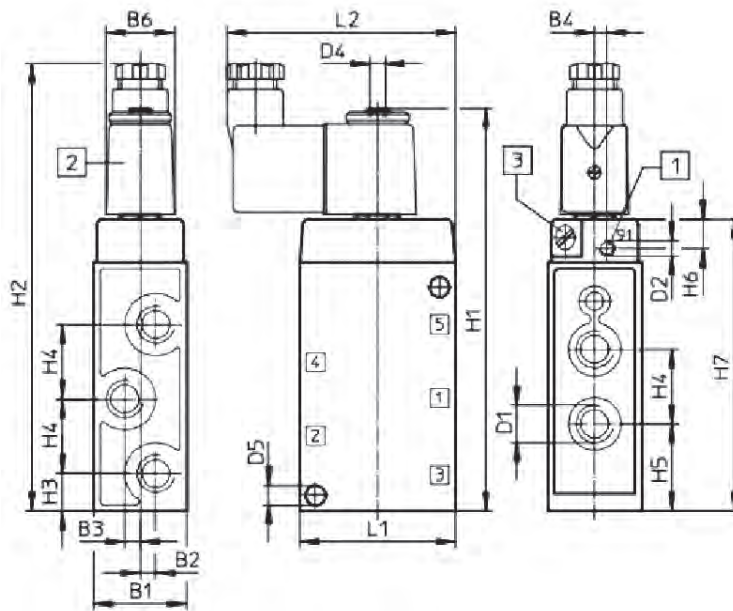

1 Connessione aggiuntiva per pilotaggio esterno.
Additional connection for external pilot.

2 Il pilota può essere ruotato di 360°.
Solenoid coil can be rotated by 360°

3 Il comando manuale può essere ruotato di 180°.
Manual override and be turned by 180°

| COD | B1 | B2 | B3 | B4 | B6 | D1 | D2 | D4 | D5 Ø | H1 | H2 | H3 | H4 | H5 | H6 | H7 | L1 | L2 |
|--------|----------|-----------|-----------|-----|----|--------|--------|----|----------|-----|-------|---------|---------|------------|------|-----|------------|------|
| 1 SMFH | 26±0,2 | 3,15±0,15 | 3,15±0,15 | // | 22 | G 1/8" | M5 | M5 | 5,5 | 117 | 131 | 13,5 | 19 | 23 | // | 83 | 45±0,15 | 71 |
| 1 SMFH | 26±0,2 | 3,5 | 3,5 | 2,7 | 22 | G 1/8" | M5 | M5 | 5,5-6,2 | 117 | 134 | 13,5 | 19±0,15 | 23 | 9,5 | 83 | 45±0,15 | 71,5 |
| 2 SMFH | 30,4±0,1 | // | 5±0,15 | // | 22 | G 1/4" | M5 | M5 | 6,5±0,14 | 128 | 143 | 12 | 24±0,15 | 28±0,1/0,2 | // | 94 | 50±0,4/0,2 | 73,5 |
| 2 SMFH | 30,4±0,1 | // | 5±0,15 | 4 | 22 | G 1/4" | M5 | M5 | Min. 6,5 | 128 | 143 | 12 | 24±0,15 | 28±0,1/0,2 | 9,5 | 94 | 50±0,4/0,2 | 73,5 |
| 3 SMFH | 52±0,15 | // | 8 | // | 22 | G 1/2" | G 1/8" | M5 | 8,5 | 192 | 208,5 | 32±0,15 | 38±0,15 | 51±0,15 | // | 158 | 80±0,4/0,2 | 87,5 |
| 3 SMFH | 52±0,15 | // | 8 | // | 22 | G 1/2" | G 1/8" | M5 | 8,5 | 192 | 208,5 | 32±0,15 | 38±0,15 | 51±0,15 | 10,5 | 158 | 80±0,4/0,2 | 87,5 |

VALVOLA TIGER BISTABILE - DOUBLE SOLENOID VALVE "TIGER" TYPE



| COD | CARATTERISTICHE - FEATURES | DIMENSIONI - SIZES | |
|-----------|----------------------------|--------------------|---|
| 1 SSMFH | | 1/8" | 1 |
| 1 SSMFH-S | 5/2 PILOTAGGIO INTERNO | 1/8" | 1 |
| 2 SSMFH | ED ESTERNO | 1/4" | 1 |
| 2 SSMFH-S | 5/2 INTERNAL AND | 1/4" | 1 |
| 3 SSMFH | EXTERNAL PILOT | 1/2" | 1 |
| 4 SSMFH-S | | 1/2" | 1 |

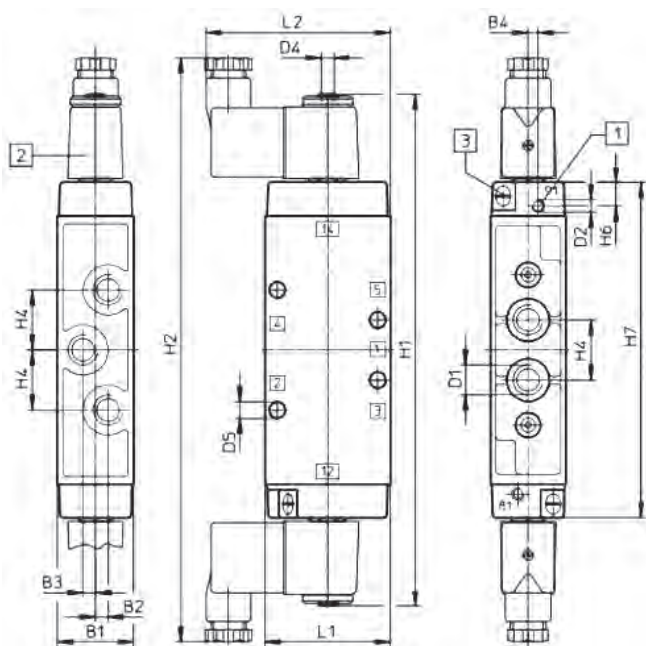

1
Connessione aggiuntiva per pilotaggio esterno.
Additional connection for external pilot.

2
Il pilota può essere ruotato di 360°.
Solenoid coil can be rotated by 360°.

3
Il comando manuale può essere ruotato di 180°.
Manual override and be turned by 180°.

| COD | B1 | B2 | B3 | B4 | D1 | D2 | D4 | D5 Ø | H1 | H2 | H4 | H6 | H7 | L1 | L2 |
|---------|----------|-----------|-----------|-----|--------|--------|----|----------|-----|-----|---------|------|-------|------------|------|
| 1 SSMFH | 26±0,2 | 3,15±0,15 | 3,15±0,15 | // | G 1/8" | // | M5 | 5,5 | 184 | 217 | 19±0,15 | // | 116,5 | 45±0,15 | 71,5 |
| 1 SSMFH | 26±0,2 | 3,15±0,15 | 3,15±0,15 | 2,7 | G 1/8" | M5 | M5 | 5,5 | 184 | 217 | 19±0,15 | 9,5 | 116,5 | 45±0,15 | 71,5 |
| 2 SSMFH | 30,4±0,1 | // | 5 | // | G 1/4" | // | M5 | Min. 6,5 | 202 | 235 | 24±0,3 | // | 134 | 50±0,4/0,2 | 74 |
| 2 SSMFH | 30,4±0,1 | // | 5 | 4 | G 1/4" | M5 | M5 | Min. 6,5 | 202 | 235 | 24±0,3 | 9,5 | 134 | 50±0,4/0,2 | 74 |
| 3 SSMFH | 52±0,15 | // | 8 | // | G 1/2" | // | M5 | 9,6±0,2 | 244 | 272 | 38 | // | 176 | 80 | 88,5 |
| 3 SSMFH | 52±0,15 | // | 8 | // | G 1/2" | G 1/8" | M5 | 8,5 | 244 | 277 | 38±0,1 | 10,5 | 176 | 80±0,4/0,2 | 87,5 |

VALVOLE A COMANDO PNEUMATICO E VALVOLE MANUALI - PNEUMATIC CONTROL VALVES AND MANUAL VALVES

VALVOLA A COMANDO PNEUMATICO MONOSTABILE 5/2 - 5/2 SINGLE PNEUMATIC PILOT VALVES

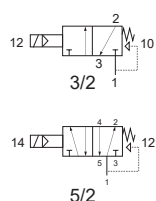
ALLUMINIO
ALUMINIUM

| COD | CARATTERISTICHE - FEATURES | DIMENSIONI - SIZES | 🛒 |
|----------|--|--------------------|---|
| 4V101-M5 | | M5 | 1 |
| 4V101-06 | 5/2 pilotaggio interno 5/2 Internal Pilot | 1/8" (P) | 1 |
| 4V201-06 | | 1/8" (G) | 1 |
| 4V201-08 | A RICHIESTA: 3/2 3/2: ON REQUEST | 1/4" (P) | 1 |
| 4V301-08 | | 1/4" (G) | 1 |
| 4V301-10 | | 3/8" | 1 |
| 4V401-15 | | 1/2" | 1 |

VALVOLA A COMANDO PNEUMATICO BISTABILE 5/2 - 5/2 DOUBLE PNEUMATIC PILOT VALVES

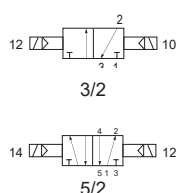
ALLUMINIO
ALUMINIUM

| COD | CARATTERISTICHE - FEATURES | DIMENSIONI - SIZES | 🛒 |
|----------|--|--------------------|---|
| 4V102-M5 | | M5 | 1 |
| 4V102-06 | 5/2 pilotaggio interno 5/2 Internal Pilot | 1/8" (P) | 1 |
| 4V202-06 | | 1/8" (G) | 1 |
| 4V202-08 | A RICHIESTA: 3/2 3/2: ON REQUEST | 1/4" (P) | 1 |
| 4V302-08 | | 1/4" (G) | 1 |
| 4V302-10 | | 3/8" | 1 |
| 4V402-15 | | 1/2" | 1 |

VALVOLA A COMANDO PNEUMATICO BISTABILE 5/3 - 5/3 DOUBLE PNEUMATIC PILOT VALVES

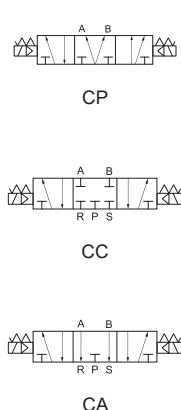
ALLUMINIO
ALUMINIUM

| COD | CARATTERISTICHE - FEATURES | DIMENSIONI - SIZES | 🛒 |
|----------|--|--------------------|---|
| 4V103-M5 | CENTRI CHIUSI - CLOSED CENTERS | M5 | 1 |
| 4V103-06 | CENTRI CHIUSI - CLOSED CENTERS | 1/8" | 1 |
| 4V203-08 | CENTRI CHIUSI - CLOSED CENTERS | 1/4" | 1 |
| 4V303-10 | CENTRI CHIUSI - CLOSED CENTERS | 3/8" | 1 |
| 4V403-15 | CENTRI CHIUSI - CLOSED CENTERS | 1/2" | 1 |
| 4V104-M5 | CENTRI IN PRESSIONE - PRESSURE CENTERS | M5 | 1 |
| 4V104-06 | CENTRI IN PRESSIONE - PRESSURE CENTERS | 1/8" | 1 |
| 4V204-08 | CENTRI IN PRESSIONE - PRESSURE CENTERS | 1/4" | 1 |
| 4V304-10 | CENTRI IN PRESSIONE - PRESSURE CENTERS | 3/8" | 1 |
| 4V404-15 | CENTRI IN PRESSIONE - PRESSURE CENTERS | 1/2" | 1 |
| 4V105-M5 | CENTRI APERTI - EXHAUST CENTERS | M5 | 1 |
| 4V105-06 | CENTRI APERTI - EXHAUST CENTERS | 1/8" | 1 |
| 4V205-08 | CENTRI APERTI - EXHAUST CENTERS | 1/4" | 1 |
| 4V305-10 | CENTRI APERTI - EXHAUST CENTERS | 3/8" | 1 |
| 4V405-15 | CENTRI APERTI - EXHAUST CENTERS | 1/2" | 1 |

VALVOLE MANUALI - MANUAL VALVES

LEVA A 90° - 90° LEVER

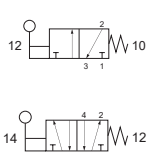

| COD | DIMENSIONI - SIZES | VERSIONE - VERSION | CARATTERISTICHE - FEATURES | 🛒 |
|-----------|--------------------|--------------------|---|---|
| LM-110-90 | 1/8" | 3/2 | | 1 |
| LM-130-90 | 1/8" | 5/2 | MATERIALE: ALLUMINIO PRESSIONE: 0-10 BAR | 1 |
| LM-210-90 | 1/4" | 3/2 | TEMPERATURA: -5°C/+85°C | 1 |
| LM-230-90 | 1/4" | 5/2 | | 1 |
| LM-310-90 | 3/8" | 3/2 | MATERIAL: ALUMINIUM PRESSIONE: 0-10 BAR | 1 |
| LM-330-90 | 3/8" | 5/2 | TEMPERATURA: -5°C/+85°C | 1 |
| LM-410-90 | 1/2" | 3/2 | | 1 |
| LM-430-90 | 1/2" | 5/2 | | 1 |

LEVA A TIRO - PULL LEVER

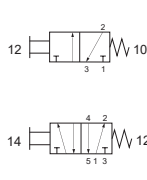

| COD | DIMENSIONI - SIZES | VERSIONE - VERSION | CARATTERISTICHE - FEATURES | 🛒 |
|----------|--------------------|--------------------|---|---|
| LM-110-T | 1/8" | 3/2 | | 1 |
| LM-130-T | 1/8" | 5/2 | MATERIALE: ALLUMINIO PRESSIONE: 0-10 BAR | 1 |
| LM-210-T | 1/4" | 3/2 | TEMPERATURA: -5°C/+85°C | 1 |
| LM-230-T | 1/4" | 5/2 | | 1 |
| LM-310-T | 3/8" | 3/2 | MATERIAL: PRESSIONE: 0-10 BAR | 1 |
| LM-330-T | 3/8" | 5/2 | TEMPERATURA: -5°C/+85°C | 1 |
| LM-410-T | 1/2" | 3/2 | | 1 |
| LM-430-T | 1/2" | 5/2 | | 1 |



SDK

SHV

SMSV

SJM





SMOV





SMSV









| SDK | | | | | |
|-----|-------------|--------------------|-----------------------------|---|---|
| | COD | DIMENSIONI SIZE | CARATTERISTICHE FEATURES | VERSIONE VERSION | 🛒 |
| | SDK 24 L6 | G 1/8" | 4/2 | Attacchi sul corpo <i>Body port</i> | 1 |
| | SDK 24 L6 D | G 1/8" | 4/2 | Attacchi posteriori <i>Botton port</i> | 1 |
| | SDK 24 L8 | G 1/4" | 4/2 | Attacchi sul corpo <i>Body port</i> | 1 |
| | SDK 24 L8 D | G 1/4" | 4/2 | Attacchi posteriori <i>Botton port</i> | 1 |
| | SDK 34 L6 | G 1/8" | 4/3 | Attacchi sul corpo <i>Body port</i> | 1 |
| | SDK 34 L6 D | G 1/8" | 4/3 | Attacchi posteriori <i>Botton port</i> | 1 |
| | SDK 34 L8 | G 1/4" | 4/3 | Attacchi sul corpo <i>Body port</i> | 1 |
| | SDK 34 L8 D | G 1/4" | 4/3 | Attacchi posteriori <i>Botton port</i> | 1 |

| SHV | | | | | |
|-----|---------|--------------------|-----------------------------|--------------------------|---|
| | COD | DIMENSIONI SIZE | CARATTERISTICHE FEATURES | VERSIONE VERSION | 🛒 |
| | SHV 200 | G 1/4" | 4/2 | Maniglia - <i>Handle</i> | 1 |
| | SHV 02 | G 1/4" | 4/2 | Pomello - <i>Knob</i> | 1 |
| | SHV 300 | G 3/8" | 4/2 | Maniglia - <i>Handle</i> | 1 |
| | SHV 03 | G 3/8" | 4/2 | Pomello - <i>Knob</i> | 1 |
| | SHV 400 | G 1/2" | 4/2 | Maniglia - <i>Handle</i> | 1 |
| | SHV 04 | G 1/2" | 4/2 | Pomello - <i>Knob</i> | 1 |
| | SHV 06 | G 3/4" | 4/2 | Pomello - <i>Knob</i> | 1 |
| | SHV 08 | G 1" | 4/2 | Pomello - <i>Knob</i> | 1 |
| | SHV 021 | G 1/4" | 4/3 | Pomello - <i>Knob</i> | 1 |
| | SHV 031 | G 3/8" | 4/3 | Pomello - <i>Knob</i> | 1 |
| | SHV 041 | G 1/2" | 4/3 | Pomello - <i>Knob</i> | 1 |
| | SHV 061 | G 3/4" | 4/3 | Pomello - <i>Knob</i> | 1 |
| | SHV 081 | G 1" | 4/3 | Pomello - <i>Knob</i> | 1 |

VALVOLE MANUALI - MANUAL VALVES

| SJM | | | | | | |
|--|---|----------|--------------------|-----------------------------|-----------------------------------|---|
| | | COD | DIMENSIONI SIZE | CARATTERISTICHE FEATURES | VERSIONE VERSION |  |
|  | Nero Black | SJM 05 | 1/8" | 3/2 | Selettore Selector knob | 1 |
|  | Nero Black Rosso Red Verde Green | SJM 06 | 1/8" | 3/2 | Fungo Mushroom head botton | 1 |
|  | Nero Black Rosso Red Verde Green | SJM 06 A | 1/8" | 3/2 | Pulsante rialzato Rised button | 1 |
|  | | SJM 07 | 1/8" | 3/2 | Rullino Roller | 1 |

| SMOV | | | | | | |
|---|---|---------|--------------------|-----------------------------|--|---|
| | | COD | DIMENSIONI SIZE | CARATTERISTICHE FEATURES | VERSIONE VERSION |  |
|  | Nero Black | SMOV 01 | 1/8" | 2/2 | Selettore Selective knob | 1 |
|  | | SMOV 02 | 1/8" | 2/2 | Pulsante di emergenza Emergency push button | 1 |
|  | Nero Black Rosso Red Verde Green | SMOV 03 | 1/8" | 2/2 | Pulsante rialzato Rised button | 1 |
|  | | SMOV 04 | 1/8" | 2/2 | Rullino Roller | 1 |

| SMSV | | | | | | |
|---|--|--------------|---------------------------|------------------------------------|---|---|
| | | COD | DIMENSIONI <i>SIZE</i> | CARATTERISTICHE <i>FEATURES</i> | VERSIONE <i>VERSION</i> |  |
|  | Nero <i>Black</i> Rosso <i>Red</i> Verde <i>Green</i> | SMSV 321 PB | 1/8" | 3/2 | Fungo <i>Mushroom head botton</i> | 1 |
| | | SMSV 322 PB | 1/4" | 3/2 | Fungo <i>Mushroom head botton</i> | 1 |
| | | SMSV 521 PB | 1/8" | 5/2 | Fungo <i>Mushroom head botton</i> | 1 |
| | | SMSV 522 PB | 1/4" | 5/2 | Fungo <i>Mushroom head botton</i> | 1 |
|  | Nero <i>Black</i> Rosso <i>Red</i> Verde <i>Green</i> | SMSV 321 PP | 1/8" | 3/2 | Pulsante a filo <i>Push button</i> | 1 |
| | | SMSV 322 PP | 1/4" | 3/2 | Pulsante a filo <i>Push button</i> | 1 |
| | | SMSV 521 PP | 1/8" | 5/2 | Pulsante a filo <i>Push button</i> | 1 |
| | | SMSV 522 PP | 1/4" | 5/2 | Pulsante a filo <i>Push button</i> | 1 |
|  | | SMSV 321 EB | 1/8" | 3/2 | Pulsante di emergenza <i>Emergency push button</i> | 1 |
| | | SMSV 322 EB | 1/4" | 3/2 | Pulsante di emergenza <i>Emergency push button</i> | 1 |
| | | SMSV 521 EB | 1/8" | 5/2 | Pulsante di emergenza <i>Emergency push button</i> | 1 |
| | | SMSV 522 EB | 1/4" | 5/2 | Pulsante di emergenza <i>Emergency push button</i> | 1 |
|  | Nero <i>Black</i> Rosso <i>Red</i> Verde <i>Green</i> | SMSV 321 PPL | 1/8" | 3/2 | Pulsante rialzato <i>Rised button</i> | 1 |
| | | SMSV 322 PPL | 1/4" | 3/2 | Pulsante rialzato <i>Rised button</i> | 1 |
| | | SMSV 521 PPL | 1/8" | 5/2 | Pulsante rialzato <i>Rised button</i> | 1 |
| | | SMSV 522 PPL | 1/4" | 5/2 | Pulsante rialzato <i>Rised button</i> | 1 |
|  | | SMSV 321 | 1/8" | 3/2 | Puntalino <i>Plunger</i> | 1 |
| | | SMSV 322 | 1/4" | 3/2 | Puntalino <i>Plunger</i> | 1 |
| | | SMSV 521 | 1/8" | 5/2 | Puntalino <i>Plunger</i> | 1 |
| | | SMSV 522 | 1/4" | 5/2 | Puntalino <i>Plunger</i> | 1 |
|  | | SMSV 321 R | 1/8" | 3/2 | Rullino <i>Roller</i> | 1 |
| | | SMSV 322 R | 1/4" | 3/2 | Rullino <i>Roller</i> | 1 |
| | | SMSV 521 R | 1/8" | 5/2 | Rullino <i>Roller</i> | 1 |
| | | SMSV 522 R | 1/4" | 5/2 | Rullino <i>Roller</i> | 1 |
|  | Nero <i>Black</i> | SMSV 321 TB | 1/8" | 3/2 | Selettore <i>Selector Knob</i> | 1 |
| | | SMSV 322 TB | 1/4" | 3/2 | Selettore <i>Selector Knob</i> | 1 |
| | | SMSV 521 TB | 1/8" | 5/2 | Selettore <i>Selector Knob</i> | 1 |
| | | SMSV 522 TB | 1/4" | 5/2 | Selettore <i>Selector Knob</i> | 1 |
|  | Nero <i>Black</i> | SMSV 321 LB | 1/8" | 3/2 | Selettore lungo <i>Long Selector Knob</i> | 1 |
| | | SMSV 322 LB | 1/4" | 3/2 | Selettore lungo <i>Long Selector Knob</i> | 1 |
| | | SMSV 521 LB | 1/8" | 5/2 | Selettore lungo <i>Long Selector Knob</i> | 1 |
| | | SMSV 522 LB | 1/4" | 5/2 | Selettore lungo <i>Long Selector Knob</i> | 1 |

SERIE VP4F - VP4FM - VPFV - VP4F - VP4FM - VPFV SERIES



VP4F210-08



VP4F210-08-L



VP3F210-08



VP4F210-08-G



VPFV420-08



VPFV320-08

| COD | VP4F210-08 | VP4F210-08L | VP4F210-08G | VP4F210-08LG | VP3F210-08 | VPFV420 | VPFV320 |
|---|--|-------------|-------------|--------------|------------|---|---------|
| Mezzo di lavoro <i>Working medium</i> | Aria filtrata a 40 micron - 40 Micron Filtered Air | | | | | | |
| Posizione e modalità NO. <i>Position and Way NO.</i> | | 5/2 | | | 3/2 | 4/2 | 3/2 |
| Modello di movimento <i>Motion Pattern</i> | Tipo di trasmissione diretta - Direct Drive Type | | | | | | |
| Dimensioni della porta <i>Port Size</i> | Ingresso aria = Uscita aria = Scarico = G 1/4" <i>Air Inlet = Air Outlet = Exhaust = G 1/4"</i> | | | | | Ingresso - Inlet = Aria - Air Uscita - Outlet = G 1/4" Scarico - Exhaust = G 1/8" | |
| Gamma di pressione del lavoro <i>Working Pressure Range</i> | 0 ~ 0,8 Mpa | | | | | | |
| Intervallo di temperatura di esercizio <i>Operatin Temperature Range</i> | 0 ~ 60 °C | | | | | | |

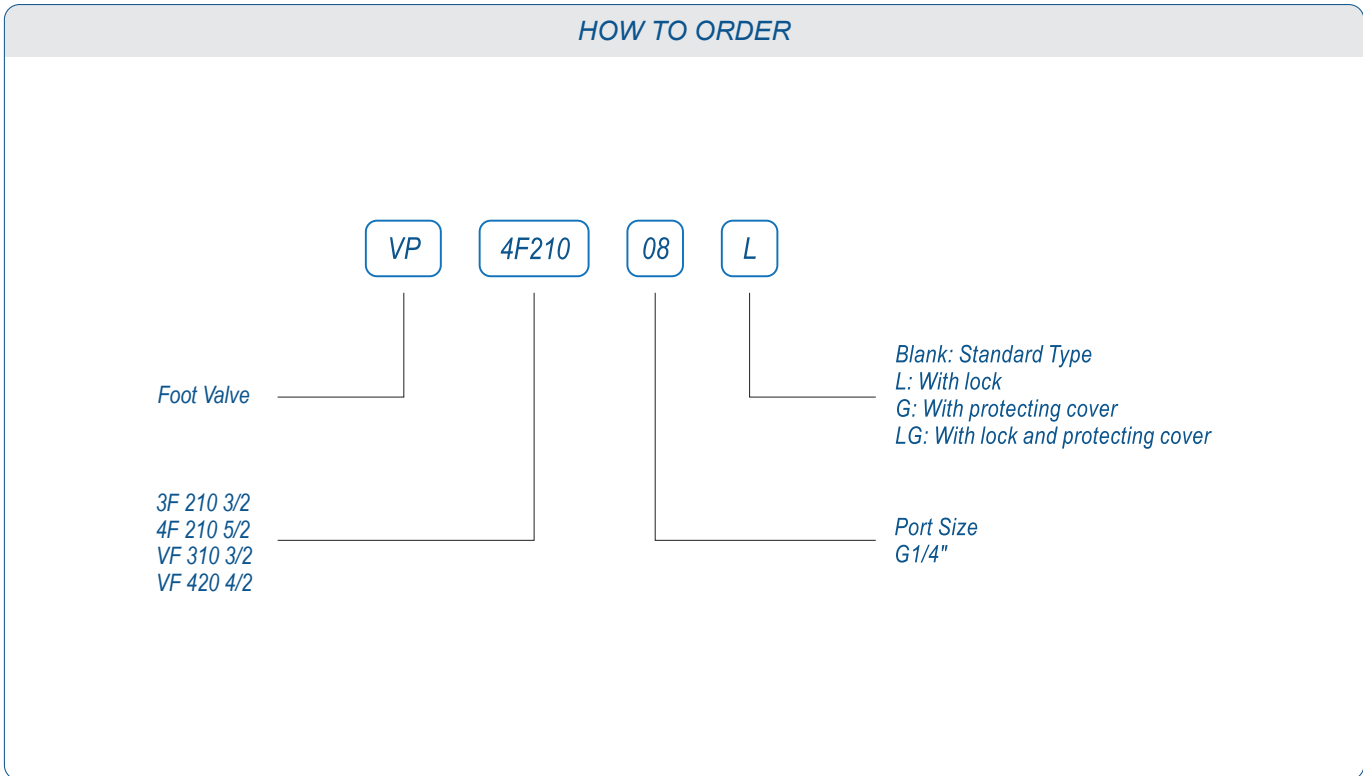
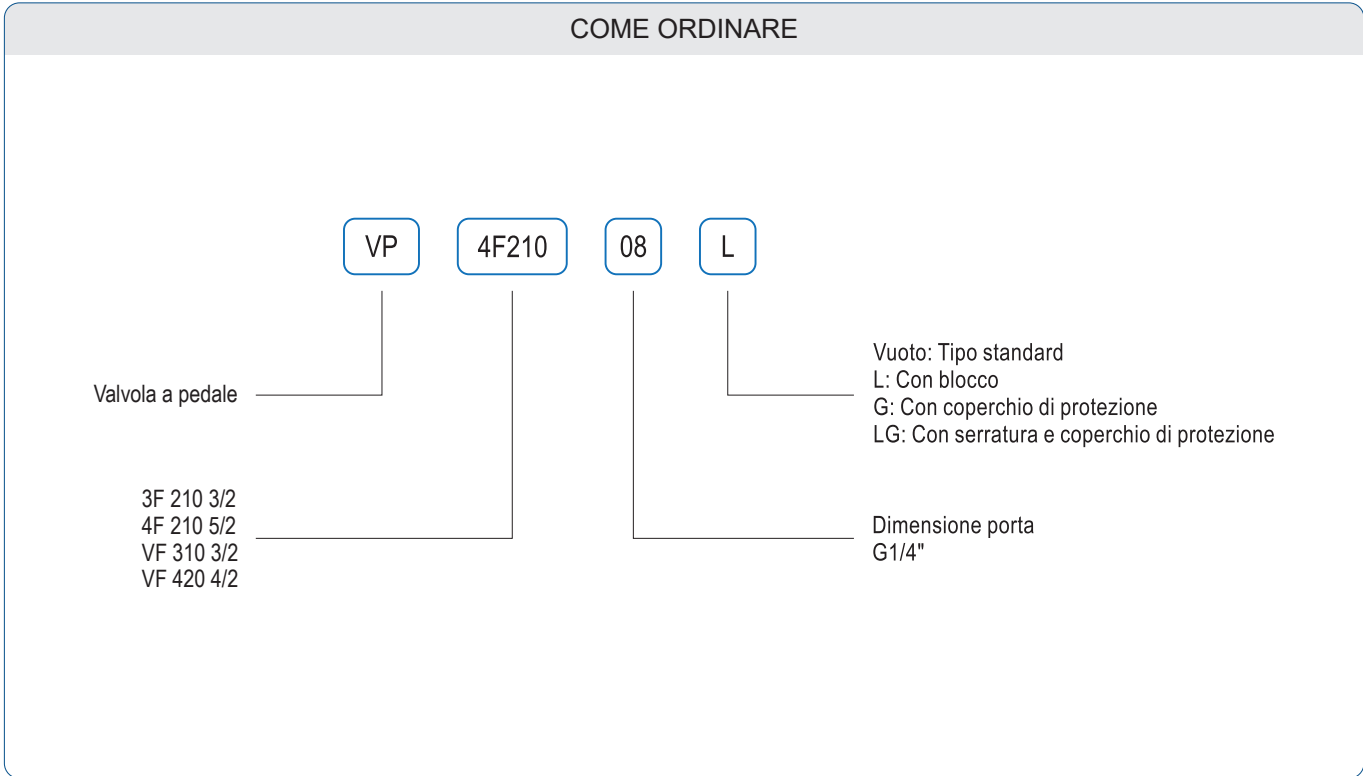

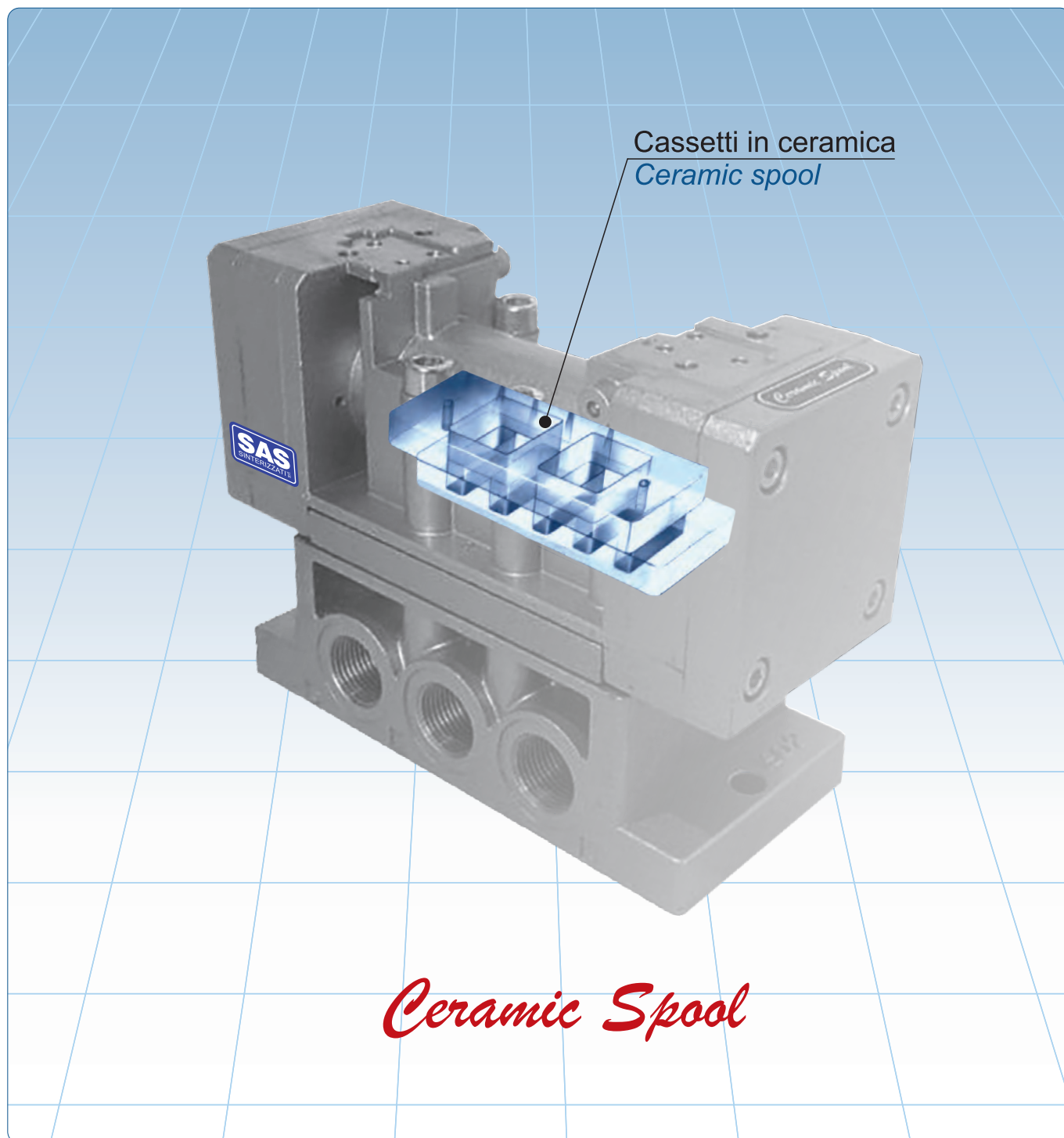

Per maggiori chiarimenti e specifiche consultare il relativo Fascicolo Tecnico.
For further clarifications and specifications, consult the relevant Technical File.

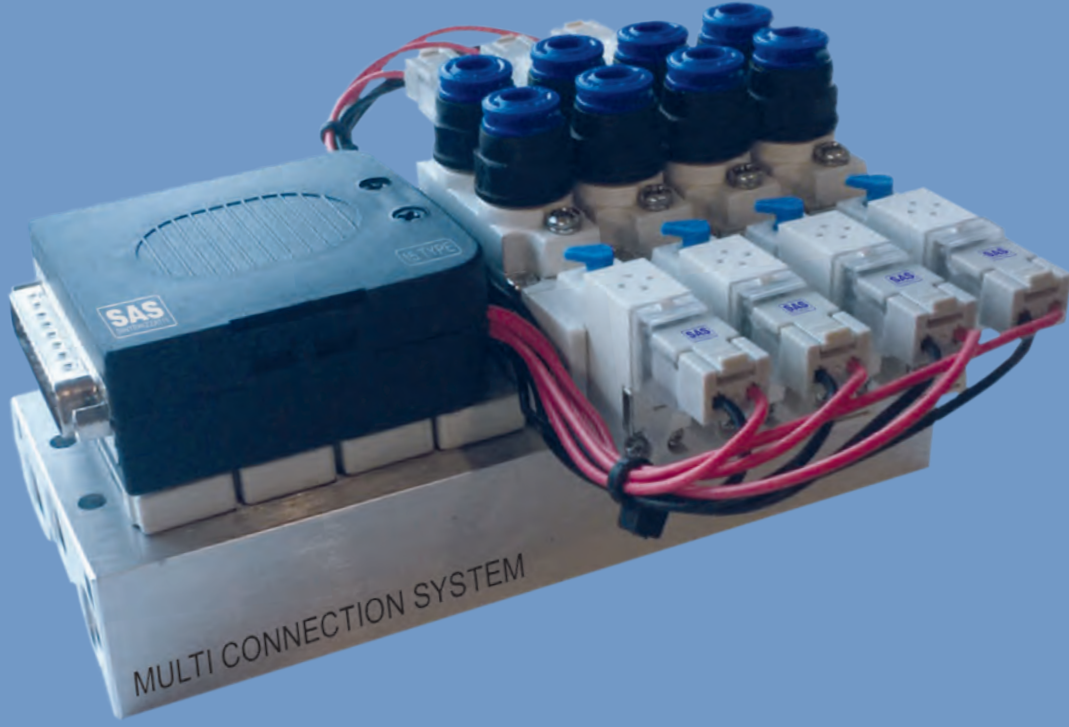

PLUG-IN TYPE SOLENOID VALVES ISLANDS

VALVOLE MULTIPOLARI - PLUG-IN TYPE SOLENOID VALVES ISLANDS

| | | | | | |
|---|---|------------|--|--------------------------------------|-----|
|  | PLUG-IN 10 | 221 |  | PLUG-IN 10 S | 223 |
|  | PLUG-IN 15 | 221 |  | PLUG-IN 15 S | 223 |
|  | PLUG-IN 18 | 221 |  | PLUG-IN 18 S | 223 |
|  | PLUG-IN 22 | 221 |  | PLUG-IN 22 S | 223 |
|  | 3 PT | 222 224 |  | M | 224 |
|  | 5 PT | 222 224 |  | PC | 224 |
|  | SCM | 222 224 |  | PLUG-IN 10 L | 225 |
|  | SCB | 222 224 |  | PLUG-IN 15 L | 225 |
|  | SCE/C/P 10 | 222 224 |  | MONOSTABILE MONOSTABLE | 226 |
|  | M | 222 224 |  | BISTABILE BISTABLE | 226 |
|  | PC | 222 224 |  | 5/3 | 226 |
|  | BOX PLUG-IN BOX PLUG-IN | 222 224 |  | MONOSTABILE MONOSTABLE PLUG IN | 226 |
|  | CAVO DI COLLEGAMENTO CONNECTION CABLE | 222 224 |  | BISTABILE BISTABLE PLUG IN | 226 |

VALVOLE MULTIPOLARI - PLUG-IN TYPE SOLENOID VALVES ISLANDS

PLUG-IN 10



PLUG-IN 15



PLUG-IN 18



PLUG-IN 22



DATI TECNICI - TECHNICAL DATA

| | SERIE - SERIES | PLUG-IN 10 | PLUG-IN 15 | PLUG-IN 18 | PLUG-IN 22 |
|--|---|---|--|------------|------------|
| FLUIDO - FLUID | | | Aria - Air | | |
| Pilotaggio interno Pressione di esercizio (MPa) <i>Internal pilot Operating pressure range (MPa)</i> | 5/2 monostabile - <i>2 position single</i> 5/2 bistabile - <i>2 position double</i> 5/3 - <i>3 position</i> | | da 1,5 a 7 Bar - <i>1.5 to 7 Bar</i> da 1 a 7 Bar - <i>1 to 7 Bar</i> da 2 a 7 Bar - <i>2 to 7 Bar</i> | | |
| Temperatura ambiente (°C) - <i>Ambient and fluid temperature (°C)</i> | | | -10 °C to +50 °C - <i>-10 °C to +50 °C</i> | | |
| Frequenza (Hz) <i>Max operating frequency (Hz)</i> | 5/2 - <i>2 position single, double</i> 5/3 - <i>3 position single</i> | 10 3 | 5 3 | 5 3 | 5 3 |
| Comando manuale <i>Manual override (Manual operation)</i> | | Senza - <i>Non-locking push type.</i> Bloccabile - <i>Push-tum locking slotted type, Push-tum locking lever type</i> | | | |
| Tipo di pilotaggio <i>Pilot exhaust method</i> | | Molla pneumatica <i>Common exhaust type for main and pilot valve</i> | | | |
| Lubrificazione <i>Lubrication</i> | | Non richiesta <i>Not required</i> | | | |

COME ORDINARE - HOW TO ORDER

PLUG-IN

15

M5

B3

E1

C3

P1

BP1

PT1/8

24 DC

DIMENSIONI - SIZES

FUNZIONE - FUNCTION

TIPO
CONNESSIONI
PORT TYPEVOLTAGGIO
VOLTAGE

| | | | | |
|----|--|--|--------|---------|
| 10 | M = monostabile - <i>single solenoid</i> | <input type="checkbox"/> = numero di valvole - <i>number of valves</i> | M5 | 12 V DC |
| 15 | B = bistabile - <i>double solenoid</i> | <input type="checkbox"/> = numero di valvole - <i>number of valves</i> | G 1/8" | 24 V DC |
| 18 | E = 5/3 CA - <i>5/3 e.c.</i> | <input type="checkbox"/> = numero di valvole - <i>number of valves</i> | G 1/4" | |
| 22 | C = 5/3 CC - <i>5/3 c.c.</i> | <input type="checkbox"/> = numero di valvole - <i>number of valves</i> | Ø 4 | |
| | P = 5/3 CP - <i>5/3 p.c.</i> | <input type="checkbox"/> = numero di valvole - <i>number of valves</i> | Ø 6 | |
| | BP = posto vuoto - <i>blank p.</i> | <input type="checkbox"/> = numero di valvole - <i>number of valves</i> | Ø 8 | |
| | | <input type="checkbox"/> = numero di valvole - <i>number of valves</i> | Ø 10 | |

VALVOLE MULTIPOLARI - PLUG-IN TYPE SOLENOID VALVES ISLANDS

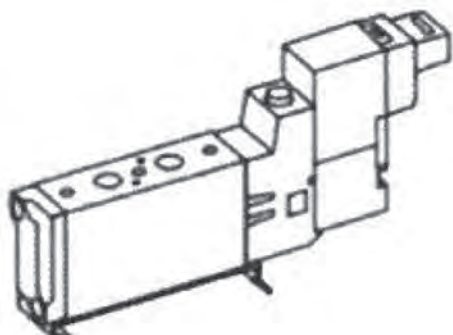

TRE VIE - THREE WAYS

| COD | 🛒 |
|-----------|---|
| 3 PT10-4 | 1 |
| 3 PT15-6 | 1 |
| 3 PT18-8 | 1 |
| 3 PT22-10 | 1 |

CINQUE VIE - FIVE WAYS

| COD | 🛒 |
|------------|---|
| 5 PT 10-4 | 1 |
| 5 PT 15-6 | 1 |
| 5 PT 18-8 | 1 |
| 5 PT 22-10 | 1 |

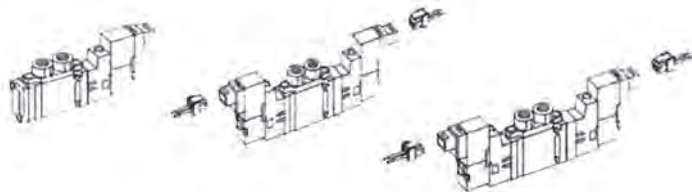

MONOSTABILE
SINGLE SOLENOID

| COD | 🛒 |
|--------|---|
| SCM 10 | 1 |
| SCM 15 | 1 |
| SCM 18 | 1 |
| SCM 22 | 1 |

BISTABILE
DOUBLE SOLENOID

| COD | 🛒 |
|--------|---|
| SCB 10 | 1 |
| SCB 15 | 1 |
| SCB 18 | 1 |
| SCB 22 | 1 |

5/3 EC-CC-PC
5/3 EC-CC-PC

| COD | 🛒 |
|------------|---|
| SCE/C/P 10 | 1 |
| SCE/C/P 15 | 1 |
| SCE/C/P 18 | 1 |
| SCE/C/P 22 | 1 |

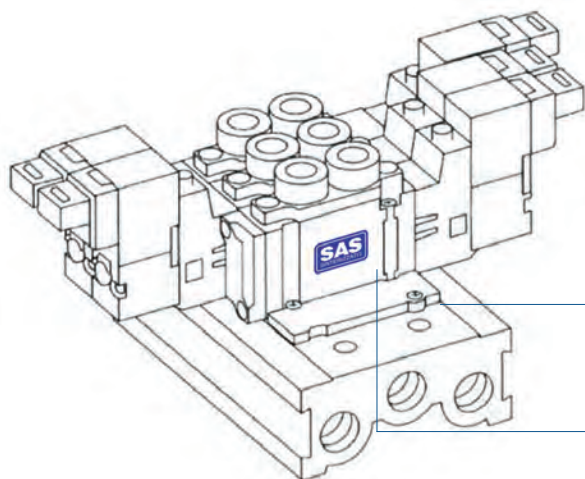

MANIFOLD - MANIFOLD

| COD | 4 | 6 | 8 | 10 | 12 |
|------|---|---|---|----|----|
| M 10 | | | | | |
| M 15 | | | | | |
| M 18 | | | | | |
| M 22 | | | | | |

| COD | 🛒 |
|-------|---|
| PC 10 | 1 |
| PC 15 | 1 |
| PC 18 | 1 |
| PC 22 | 1 |

BOX PLUG-IN - BOX PLUG-IN

| COD | 🛒 |
|-----|---|
| BOX | 1 |



CAVO DI COLLEGAMENTO - CONNECTION CABLE

| COD | NO. POLI POLES | IP | LUNGH. LENGTH | 🛒 |
|--------|-------------------|----|------------------|---|
| CAVO 1 | 25 | 44 | 3 mt | 1 |
| CAVO 2 | 25 | 44 | 5 mt | 1 |
| CAVO 3 | 25 | 44 | 10 mt | 1 |
| CAVO 4 | 25 | 65 | 3 mt | 1 |
| CAVO 5 | 25 | 65 | 5 mt | 1 |
| CAVO 6 | 25 | 65 | 10 mt | 1 |

PREZZI A RICHIESTA - PRICES ON REQUEST



PLUG-IN 10 S

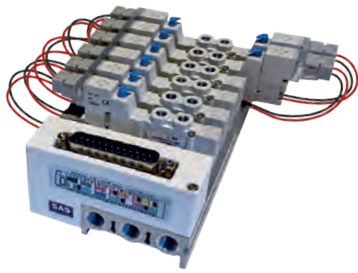

PLUG-IN 15 S

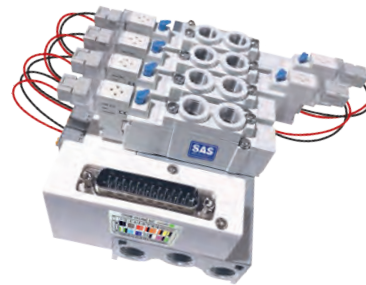

PLUG-IN 18 S

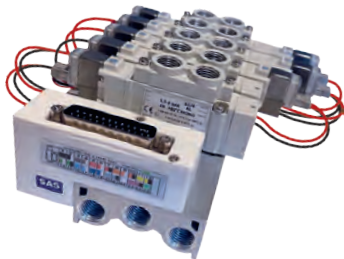

PLUG-IN 22 S



DATI TECNICI - TECHNICAL DATA

| SERIE - SERIES | PLUG-IN 10 S | PLUG-IN 15 S | PLUG-IN 18 S | PLUG-IN 22 S |
|--|-------------------------------------|---|------------------|--------------|
| FLUIDO - FLUID | | Aria - Air | | |
| Pilotaggio interno Pressione di esercizio (MPa) <i>Internal pilot Operating pressure range (MPa)</i> | 5/2 monostabile - 2 position single | da 1,5 a 7 Bar - 1,5 to 7 Bar | | |
| | 5/2 bistabile - 2 position double | da 1 a 7 Bar - 1 to 7 Bar | | |
| | 5/3 - 3 position | da 2 a 7 Bar - 2 to 7 Bar | | |
| Temperatura ambiente (°C) - Ambient and fluid temperature (°C) | | -10 °C to +50 °C | -10 °C to +50 °C | |
| Frequenza (Hz) <i>Max operating frequency (Hz)</i> | 5/2 - 2 position single, double | 10 | 5 | 5 |
| | 5/3 - 3 position single | 3 | 3 | 3 |
| Comando manuale <i>Manual override (Manual operation)</i> | | Senza - Non-locking push type. Bloccabile - Push-turn locking slotted type, Push-turn locking lever type | | |
| Tipo di pilotaggio <i>Pilot exhaust method</i> | | Molla pneumatica Common exhaust type for main and pilot valve | | |
| Lubrificazione <i>Lubrication</i> | | Non richiesta Not required | | |

COME ORDINARE - HOW TO ORDER

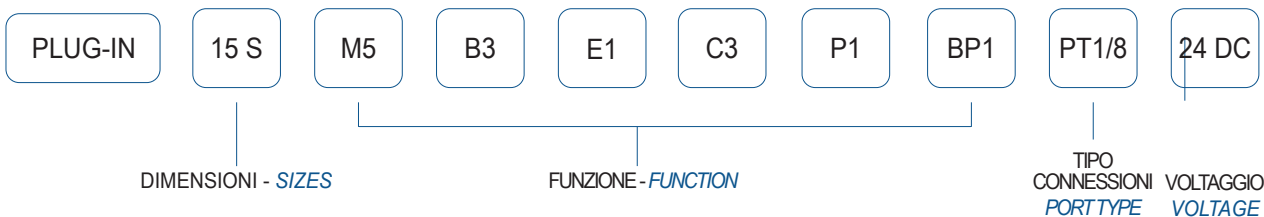

VALVOLE MULTIPOLARI - PLUG-IN TYPE SOLENOID VALVES ISLANDS

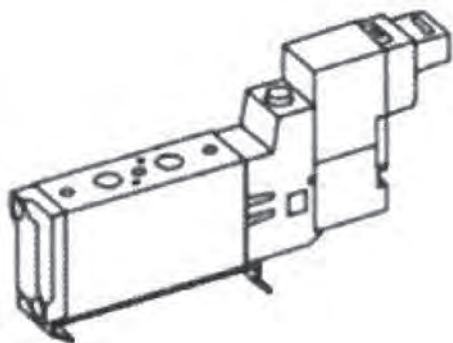

TRE VIE - THREE WAYS

| COD | 🛒 |
|-----------|---|
| 3 PT10-4 | 1 |
| 3 PT15-6 | 1 |
| 3 PT18-8 | 1 |
| 3 PT22-10 | 1 |

CINQUE VIE - FIVE WAYS

| COD | 🛒 |
|------------|---|
| 5 PT 10-4 | 1 |
| 5 PT 15-6 | 1 |
| 5 PT 18-8 | 1 |
| 5 PT 22-10 | 1 |

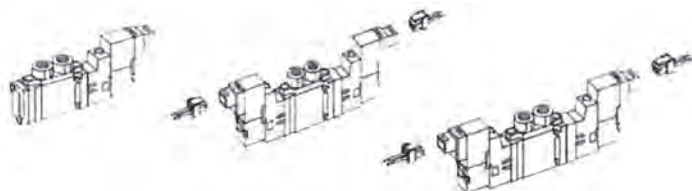

MONOSTABILE
SINGLE SOLENOID

| COD | 🛒 |
|--------|---|
| SCM 10 | 1 |
| SCM 15 | 1 |
| SCM 18 | 1 |
| SCM 22 | 1 |

BISTABILE
DOUBLE SOLENOID

| COD | 🛒 |
|--------|---|
| SCB 10 | 1 |
| SCB 15 | 1 |
| SCB 18 | 1 |
| SCB 22 | 1 |

5/3 EC-CC-PC
5/3 EC-CC-PC

| COD | 🛒 |
|------------|---|
| SCE/C/P 10 | 1 |
| SCE/C/P 15 | 1 |
| SCE/C/P 18 | 1 |
| SCE/C/P 22 | 1 |

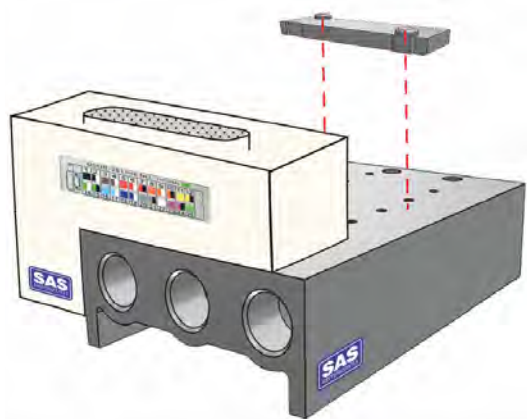

MANIFOLD PLUG-IN - MANIFOLD PLUG-IN

| COD | 4 | 6 | 8 | 10 | 12 |
|--------|---|---|---|----|----|
| M 10 S | | | | | |
| M 15 S | | | | | |
| M 18 S | | | | | |
| M 22 S | | | | | |

| COD | 🛒 |
|-------|---|
| PC 10 | 1 |
| PC 15 | 1 |
| PC 18 | 1 |
| PC 22 | 1 |

CAVO DI COLLEGAMENTO - CONNECTION CABLE

| COD | NO. POLI POLES | IP | LUNGH. LENGTH | 🛒 |
|--------|-------------------|----|------------------|---|
| CAVO 1 | 25 | 44 | 3 mt | 1 |
| CAVO 2 | 25 | 44 | 5 mt | 1 |
| CAVO 3 | 25 | 44 | 10 mt | 1 |
| CAVO 4 | 25 | 65 | 3 mt | 1 |
| CAVO 5 | 25 | 65 | 5 mt | 1 |
| CAVO 6 | 25 | 65 | 10 mt | 1 |

PREZZI A RICHIESTA - PRICES ON REQUEST



PLUG-IN 10 L - PLUG-IN 10 L TYPE

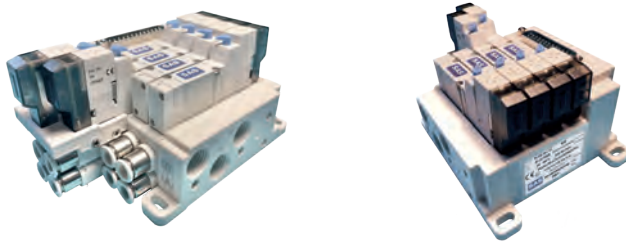

| | | | |
|---|--------------|-------------|-------------|
| MODEL | PLUG-IN L 10 | PORT SIZE | M5 |
| PRESS. | 0+8 BAR | MATERIAL | AL + PA |
| TEMP. | -20 + +80°C | STANDARD | 400 NI/min. |
| PLUG-IN-L10-C1B1M2PT6 II 3D EXH IIIC T85°C Dc | | | |
| ASSEMBLED IN ITALY SAS SINTERIZZATI SRL ITALY | | SERIAL NBR. | 0001 |
| | | YEAR | 2022 |

PLUG-IN 15 L - PLUG-IN 15 L TYPE



| | | | |
|---|--------------|-------------|-------------|
| MODEL | PLUG-IN L 15 | PORT SIZE | 6 mm |
| PRESS. | 0+16 BAR | MATERIAL | AL + PA |
| TEMP. | -20 + +80°C | STANDARD | 750 NI/min. |
| PLUG-IN-L15 B2 M4PT6 24 DC II 3D EXH IIIC T85°C Dc | | | |
| ASSEMBLED IN ITALY SAS SINTERIZZATI SRL ITALY | | SERIAL NBR. | 0001 |
| | | YEAR | 2022 |

DATI TECNICI - TECHNICAL DATA

| SERIE - SERIES | | PLUG-IN 10 L - PLUG-IN 15 L | | | |
|--|--|---|--------|--------|--------|
| FLUIDO - FLUID | | Aria - Air | | | |
| Pilotaggio interno Pressione di esercizio (MPa) <i>Internal pilot Operating pressure range (MPa)</i> | 5/2 monostabile - 2 position single 5/2 bistabile - 2 position double 5/3 - 3 position | da 1,5 a 7 Bar - 1,5 to 7 Bar da 1 a 7 Bar - 1 to 7 Bar da 2 a 7 Bar - 2 to 7 Bar | | | |
| Temperatura ambiente (°C) - Ambient and fluid temperature (°C) | | -10 °C to +50 °C -10 °C to +50 °C | | | |
| Frequenza (Hz) <i>Max operating frequency (Hz)</i> | 5/2 - 2 position single, double 5/3 - 3 position single | 10 3 | 5 3 | 5 3 | 5 3 |
| Comando manuale <i>Manual override (Manual operation)</i> | | Senza - Non-locking push type. Bloccabile - Push-turn locking slotted type, Push-turn locking lever type | | | |
| Tipo di pilotaggio <i>Pilot exhaust method</i> | | Molla pneumatica Common exhaust type for main and pilot valve | | | |
| Lubrificazione <i>Lubrication</i> | | Non richiesta Not required | | | |

COME ORDINARE - HOW TO ORDER

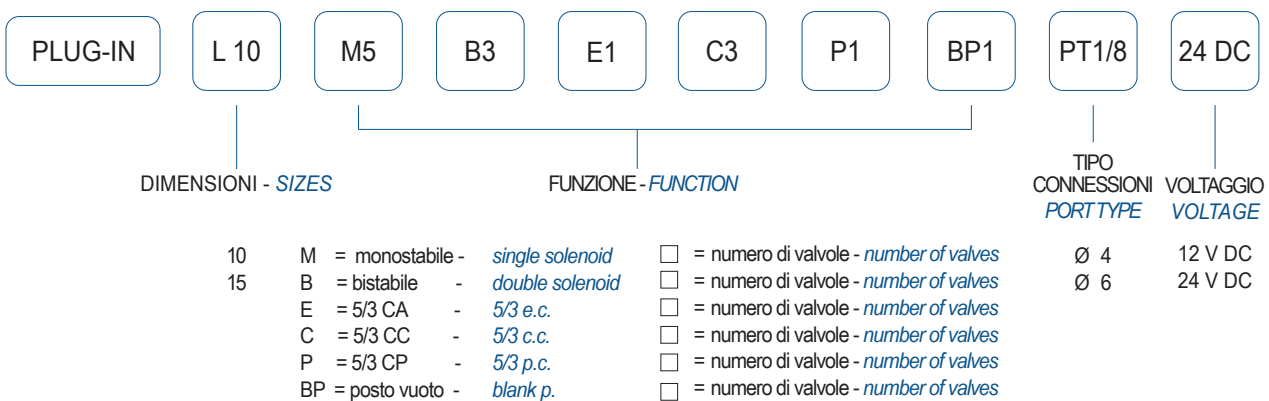

VALVOLE MULTIPOLARI - PLUG-IN TYPE SOLENOID VALVES ISLANDS



MONOSTABILE - MONOSTABLE

| DIMENSIONI - SIZES | 🛒 |
|--------------------|---|
| 10 | 1 |
| 15 | 1 |



BISTABILE - BISTABLE

| DIMENSIONI - SIZES | 🛒 |
|--------------------|---|
| 10 | 1 |
| 15 | 1 |



5/3

| DIMENSIONI - SIZES | 🛒 |
|--------------------|---|
| 10 | 1 |
| 15 | 1 |



MONOSTABILE - MONOSTABLE

| COD | 🛒 |
|-----------------|---|
| PLUG-IN □ L M2 | 1 |
| PLUG-IN □ L M3 | 1 |
| PLUG-IN □ L M4 | 1 |
| PLUG-IN □ L M5 | 1 |
| PLUG-IN □ L M6 | 1 |
| PLUG-IN □ L M7 | 1 |
| PLUG-IN □ L M8 | 1 |
| PLUG-IN □ L M9 | 1 |
| PLUG-IN □ L M10 | 1 |
| PLUG-IN □ L M11 | 1 |
| PLUG-IN □ L M12 | 1 |



BISTABILE - BISTABLE

| COD | 🛒 |
|-----------------|---|
| PLUG-IN □ L B2 | 1 |
| PLUG-IN □ L B3 | 1 |
| PLUG-IN □ L B4 | 1 |
| PLUG-IN □ L B5 | 1 |
| PLUG-IN □ L B6 | 1 |
| PLUG-IN □ L B7 | 1 |
| PLUG-IN □ L B8 | 1 |
| PLUG-IN □ L B9 | 1 |
| PLUG-IN □ L B10 | 1 |
| PLUG-IN □ L B11 | 1 |
| PLUG-IN □ L B12 | 1 |

CAVO DI COLLEGAMENTO - CONNECTION CABLE

| COD | NO. POLI POLES | IP | LUNGH. LENGTH | 🛒 | € |
|--------|-------------------|----|------------------|---|---|
| CAVO 1 | 25 | 44 | 3 mt | 1 | |
| CAVO 2 | 25 | 44 | 5 mt | 1 | |
| CAVO 3 | 25 | 44 | 10 mt | 1 | |
| CAVO 4 | 25 | 65 | 3 mt | 1 | |
| CAVO 5 | 25 | 65 | 5 mt | 1 | |
| CAVO 6 | 25 | 65 | 10 mt | 1 | |

PREZZI A RICHIESTA - PRICES ON REQUEST





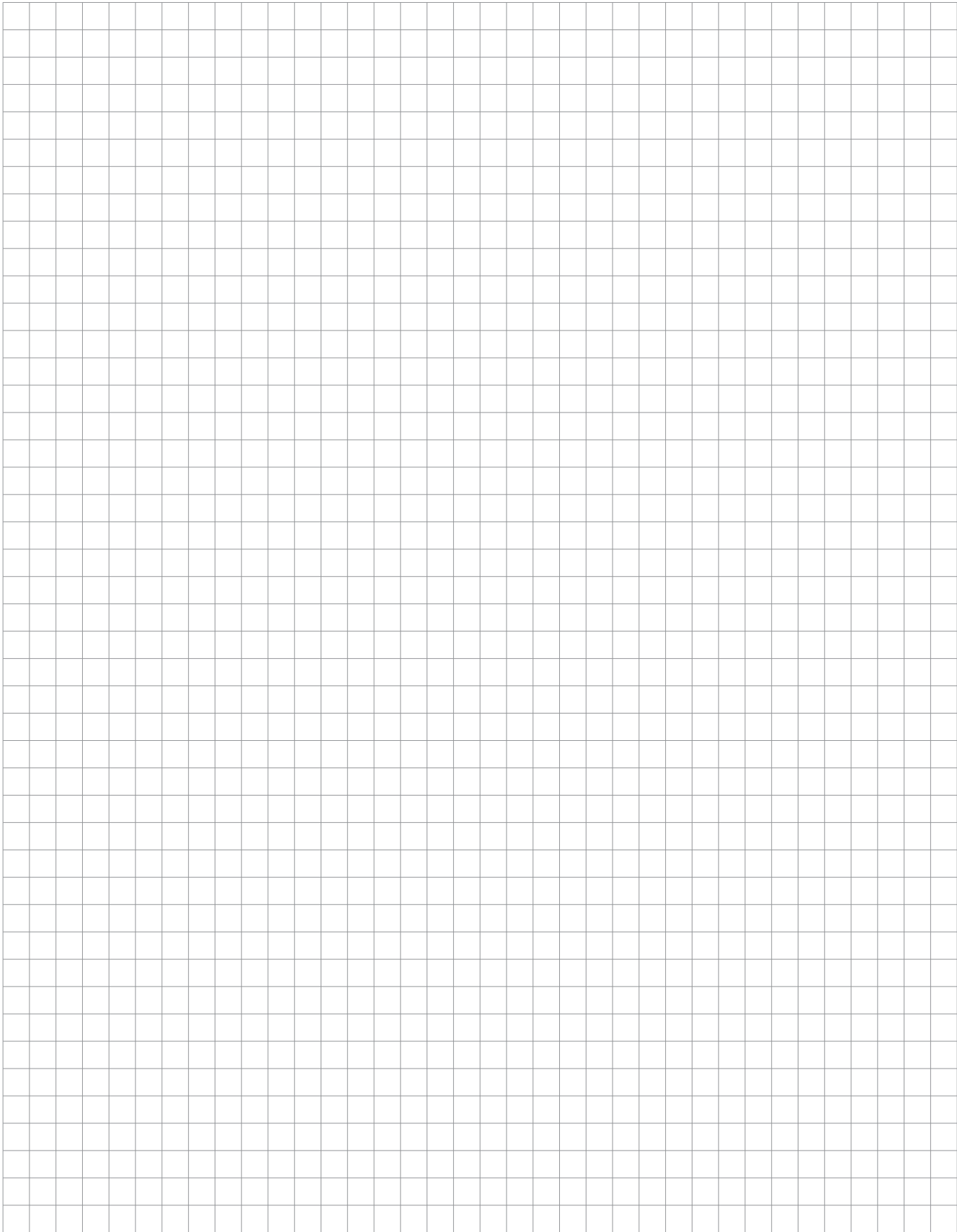



PROFINET: A RICHIESTA - PROFINET: ON REQUEST





CYLINDERS

| | | | | | |
|---|--|-----|--|---|-----|
|  | CILINDRI COMPATTI ISO 21287 ISO 21287 COMPACT CYLINDERS | 232 |  | T VERSIONE ALLUMINIO ALUMINIUM VERSION | 235 |
|  | CILINDRI COMPATTI I SO 21287 ANTI ROTAZIONE ISO 21287 ANTI ROTATION COMPACT CYLINDERS | 232 |  | ALESAGGIO Ø 25 BORE SIZE Ø 25 | 236 |
|  | MINICILINDRI ISO 6432 ALLUMINIO ISO 6432 ALLUMINIUM MINI CYLINDERS | 233 |  | ALESAGGIO Ø 32 - 40 - 50 - 63 BORE SIZES Ø 32 - 40 - 50 - 63 | 236 |
|  | MINICILINDRI ISO 6432 INOX ISO 6432 STAINLESS STEEL MINI CYLINDERS | 233 |  | UNITÀ DI GUIDA TIPO H CON BOCCOLE DI SCORRIMENTO H PROFILE GUIDING UNIT WITH SINTERED BRONZE GUIDE | 237 |
|  | CILINDRI STANDARD ALLUMINIO ISO 15552 ISO 15552 ALUMINIUM STANDARD CYLINDERS | 234 |  | UNITÀ DI GUIDA TIPO H CON MANICOTTO A SFERE H PROFILE GUIDING UNIT WITH RECIRCULATING BALL SLEEVES | 237 |
|  | KIT PER CILINDRI ALLUMINIO ISO 15552 ISO 15552 ALUMINIUM STANDARD CYLINDERS MOUNTING KIT | 234 |  | UNITÀ DI GUIDA TIPO U CON BOCCOLE DI SCORRIMENTO U PROFILE GUIDING UNIT WITH SINTERED BRONZE GUIDE | 237 |
|  | CILINDRI STANDARD INOX ISO 15552 ISO 15552 INOX STANDARD CYLINDERS | 235 |  | KIT UNITÀ DI GUIDA TIPO H H PROFILE GUIDING KIT | 237 |
|  | # VERSIONE ALLUMINIO ALUMINIUM VERSION | 235 |  | KIT UNITÀ DI GUIDA TIPO U U PROFILE GUIDING KIT | 237 |

| | | | | | |
|---|----------|-----|--|--|-----|
|  | CSS - M0 | 238 |  | SZK | 240 |
|  | CSS - M1 | 238 |  | SZF | 240 |
|  | CSS - M2 | 238 |  | SZFK | 241 |
|  | CSS - M3 | 238 |  | SZFF | 241 |
|  | CSS - P0 | 239 |  | DECELERATORI SERIE AC SHOCK ABSORBERS AC SERIES | 240 |
|  | CSS - P1 | 239 |  | DECELERATORI SERIE AD SHOCK ABSORBERS AD SERIES | 243 |
|  | CSS - P2 | 239 | | | |
|  | SZS | 240 | | | |

CILINDRI PNEUMATICI - PNEUMATIC CYLINDERS

CILINDRI COMPATTI ISO 21287 - ISO 21287 COMPACT CYLINDERS

Cilindri compatti ISO 21287 Ø 20 - 100 mm
 Pressione di esercizio bar 1,5 ÷ 10
 Temperatura ambiente °C -20 ÷ + 80

ISO 21287 Compact Cylinders Ø 20 - 100 mm
 Operating pressure bar 1,5 ÷ 10
 Operating temperature °C -20 ÷ + 80



Serie C2B
 I codici dei nostri prodotti seguono la seguente regola:
 C2B - Ø - C
 C2B = sigla modello
 Ø = diametro cilindro
 C = corsa standard
 Es: C2B - 2040 = serie C2B con Ø 20 corsa 40
 Sensore magnetico tipo SMAP

C 2B Series
 The codes of our products follow these rule:
 C2B - Ø - C
 C2B = model
 Ø = bore size
 C = standard stroke
 Ex: C2B - 2040 = C2B series (Ø 20 stroke 40)
 Magnetic Sensor: SMAP type

ALESAGGIO
 BORE SIZES

CORSE STANDARD - STANDARD STROKES

| | Ø 16 | Ø 20 | Ø 25 | Ø 32 | Ø 40 | Ø 50 | Ø 63 | Ø 80 |
|-----------------------|------|------|------|---------------------------------|------|------|------|------|
| Ø 16 | | | | 5 - 10 - 15 - 20 - 25 - 30 - 50 | | | | |
| Ø 20 | | | | 5 - 10 - 15 - 20 - 25 - 30 - 50 | | | | |
| Ø 25 | | | | 5 - 10 - 15 - 20 - 25 - 30 - 50 | | | | |
| Ø 32 | | | | 5 - 10 - 15 - 20 - 25 - 30 - 50 | | | | |
| Ø 40 | | | | 5 - 10 - 15 - 20 - 25 - 30 - 50 | | | | |
| Ø 50 | | | | 10 - 15 - 20 - 25 - 30 - 50 | | | | |
| Ø 63 | | | | 10 - 15 - 20 - 25 - 30 - 50 | | | | |
| Ø 80 | | | | 10 - 15 - 20 - 25 - 30 - 50 | | | | |
| ALESAGGIO - BORE SIZE | | | | | | | | |
| CORSA STROKE mm | Ø 16 | Ø 20 | Ø 25 | Ø 32 | Ø 40 | Ø 50 | Ø 63 | Ø 80 |
| 5mm | 1 | 1 | 1 | 1 | 1 | 1 | 1 | 1 |
| 10mm | 1 | 1 | 1 | 1 | 1 | 1 | 1 | 1 |
| 15mm | 1 | 1 | 1 | 1 | 1 | 1 | 1 | 1 |
| 20mm | 1 | 1 | 1 | 1 | 1 | 1 | 1 | 1 |
| 25mm | 1 | 1 | 1 | 1 | 1 | 1 | 1 | 1 |
| 30mm | 1 | 1 | 1 | 1 | 1 | 1 | 1 | 1 |
| 35mm | 1 | 1 | 1 | 1 | 1 | 1 | 1 | 1 |
| 40mm | 1 | 1 | 1 | 1 | 1 | 1 | 1 | 1 |
| 50mm | 1 | 1 | 1 | 1 | 1 | 1 | 1 | 1 |

CILINDRI COMPATTI ISO 21287 ANTI ROTAZIONE - ISO 21287 ANTI ROTATION COMPACT CYLINDERS

Cilindri compatti ISO 21287 AR Ø 20 - 100 mm
 Pressione di esercizio bar 1,5 ÷ 10
 Temperatura ambiente °C -20 ÷ + 80

ISO 21287 AR Compact Cylinders Ø 20 - 100 mm
 Operating pressure bar 1,5 ÷ 10
 Operating temperature °C -20 ÷ + 80



Serie C 2B - AR
 I codici dei nostri prodotti seguono la seguente regola:
 C2B AR - Ø - C
 C2B AR = sigla modello
 Ø = diametro cilindro
 C = corsa standard
 Es: C2B AR - 2040 = serie C2B AR con Ø 20 corsa 40

C 2B - AR Series
 The codes of our products follow these rule:
 C2B AR - Ø - C
 C2B AR = model
 Ø = bore size
 C = standard stroke
 Ex: C2B AR - 2040 = C2B AR series (Ø 20 stroke 40)

ALESAGGIO
 BORE SIZES

CORSE STANDARD - STANDARD STROKES

| | Ø 16 | Ø 20 | Ø 25 | Ø 32 | Ø 40 | Ø 50 | Ø 63 | Ø 80 |
|-----------------------|------|------|------|---------------------------------|------|------|------|------|
| Ø 16 | | | | 5 - 10 - 15 - 20 - 25 - 30 - 50 | | | | |
| Ø 20 | | | | 5 - 10 - 15 - 20 - 25 - 30 - 50 | | | | |
| Ø 25 | | | | 5 - 10 - 15 - 20 - 25 - 30 - 50 | | | | |
| Ø 32 | | | | 5 - 10 - 15 - 20 - 25 - 30 - 50 | | | | |
| Ø 40 | | | | 5 - 10 - 15 - 20 - 25 - 30 - 50 | | | | |
| Ø 50 | | | | 10 - 15 - 20 - 25 - 30 - 50 | | | | |
| Ø 63 | | | | 10 - 15 - 20 - 25 - 30 - 50 | | | | |
| Ø 80 | | | | 10 - 15 - 20 - 25 - 30 - 50 | | | | |
| ALESAGGIO - BORE SIZE | | | | | | | | |
| CORSA STROKE mm | Ø 16 | Ø 20 | Ø 25 | Ø 32 | Ø 40 | Ø 50 | Ø 63 | Ø 80 |
| 5 mm | 1 | 1 | 1 | 1 | 1 | 1 | 1 | 1 |
| 10 mm | 1 | 1 | 1 | 1 | 1 | 1 | 1 | 1 |
| 15 mm | 1 | 1 | 1 | 1 | 1 | 1 | 1 | 1 |
| 20 mm | 1 | 1 | 1 | 1 | 1 | 1 | 1 | 1 |
| 25 mm | 1 | 1 | 1 | 1 | 1 | 1 | 1 | 1 |
| 30 mm | 1 | 1 | 1 | 1 | 1 | 1 | 1 | 1 |
| 35 mm | 1 | 1 | 1 | 1 | 1 | 1 | 1 | 1 |
| 40 mm | 1 | 1 | 1 | 1 | 1 | 1 | 1 | 1 |
| 45 mm | 1 | 1 | 1 | 1 | 1 | 1 | 1 | 1 |
| 50 mm | 1 | 1 | 1 | 1 | 1 | 1 | 1 | 1 |

MINICILINDRI ISO 6432 ALLUMINIO - ISO 6432 ALLUMINIUM MINI CYLINDERS

Minicilindri ISO 6432 Ø 10-25 mm
 Pressione di esercizio bar 1,5 ÷ 10
 Temperatura ambiente °C -20 ÷ 80
 Fluido aria filtrata, lubrificata o non
 Camicia acciaio inox AISI 304
 Testate alluminio (cianfrinate)
 Stelo acciaio inox AISI 303
 Pistone Ø 10 ÷ 16 in ottone; Ø 20 ÷ 25 alluminio
 Guarnizioni gomma nitrilica

ISO 6432 Mini Cylinders Ø 10-25 mm
 Working pressure bar 1,5 ÷ 10
 Working temperature °C -20 ÷ 80
 Fluid filtered air (lubricated or not)
 Barrel stainless steel AISI 304
 Caps aluminium
 Piston rod stainless steel AISI 303
 Piston Ø 10 ÷ 16 brass - Ø 20 ÷ 25 aluminium
 Seals NBR



Serie M
 Questi cilindri, privi di spigoli e molto lineari, sono particolarmente indicati dove viene richiesta, unitamente ad un'elevata affidabilità, una facile pulizia (settore alimentare, farmaceutico, ecc.)
 Codifica
 I codici dei nostri prodotti seguono la seguente regola: M - Ø - C
 M = sigla modello Ø = diametro cilindro C = corsa standard
 Es: M - 1040 = serie M con Ø 10 corsa 40
 Sensore magnetico tipo SMAP

M SERIES
 These cylinders, without edges, are particularly suitable when high reliability and easy cleaning are required. (Food and pharmaceutical sectors).
 The codes of our products follow these rule:
 M - Ø - C
 M = model Ø = bore size C = standard stroke
 Ex: M - 1040 = M series (Ø 10 - stroke 40)
 Magnetic sensor: SMAP Type

| ALESAGGIO | | CORSE STANDARD - STANDARD STROKES | | | | |
|------------|--|--|--|--|--|--|
| BORE SIZES | | | | | | |
| Ø 10 | | 25 - 50 - 75 - 100 - 125 - 150 - 175 - 200 - 225 - 250 - 275 - 300 | | | | |
| Ø 12 | | 25 - 50 - 75 - 100 - 125 - 150 - 175 - 200 - 225 - 250 - 275 - 300 | | | | |
| Ø 16 | | 25 - 50 - 75 - 100 - 125 - 150 - 175 - 200 - 225 - 250 - 275 - 300 | | | | |
| Ø 20 | | 25 - 50 - 75 - 100 - 125 - 150 - 175 - 200 - 225 - 250 - 275 - 300 | | | | |
| Ø 25 | | 25 - 50 - 75 - 100 - 125 - 150 - 175 - 200 - 225 - 250 - 275 - 300 | | | | |

| CORSIA | | ALESAGGIO - BORE SIZE | | | | |
|--------|--|-----------------------|------|------|------|------|
| STROKE | | Ø 10 | Ø 12 | Ø 16 | Ø 20 | Ø 25 |
| mm | | ☐ | ☐ | ☐ | ☐ | ☐ |
| 25 mm | | 1 | 1 | 1 | 1 | 1 |
| 50 mm | | 1 | 1 | 1 | 1 | 1 |
| 75 mm | | 1 | 1 | 1 | 1 | 1 |
| 100 mm | | 1 | 1 | 1 | 1 | 1 |
| 125 mm | | 1 | 1 | 1 | 1 | 1 |
| 150 mm | | 1 | 1 | 1 | 1 | 1 |
| 175 mm | | 1 | 1 | 1 | 1 | 1 |
| 200 mm | | 1 | 1 | 1 | 1 | 1 |
| 225 mm | | 1 | 1 | 1 | 1 | 1 |
| 250 mm | | 1 | 1 | 1 | 1 | 1 |
| 275 mm | | 1 | 1 | 1 | 1 | 1 |
| 300 mm | | 1 | 1 | 1 | 1 | 1 |
| +50 mm | | 1 | 1 | 1 | 1 | 1 |

MINICILINDRI ISO 6432 INOX - ISO 6432 STAINLESS STEEL MINI CYLINDERS

Minicilindri ISO 6432 INOX Ø 10-25 mm
 Pressione di esercizio bar 1,5 ÷ 10
 Temperatura ambiente °C -20 ÷ +80
 Fluido aria filtrata, lubrificata o non
 Camicia acciaio inox AISI 304
 Testate acciaio inox AISI 304
 Stelo acciaio inox AISI 303
 Pistone Ø 10 ÷ 16 AISI 30 - Ø 20 ÷ 25 AISI 304
 Guarnizioni gomma nitrilica

ISO 6432 Stainless Steel Mini Cylinders Ø 10-25 mm
 Working pressure bar 1,5 ÷ 10
 Working temperature °C -20 ÷ 80
 Fluid filtered air (lubricated or not)
 Barrel stainless steel (SS) AISI 304
 Caps stainless steel (SS) AISI 304
 Piston rod stainless steel (SS) AISI 303
 Piston Ø 10 ÷ SS AISI 304 - Ø 20 ÷ 25 SS AISI 304
 Seals NBR



Serie M X
 Questi cilindri, privi di spigoli e molto lineari, sono particolarmente indicati dove viene richiesta, unitamente ad un'elevata affidabilità, una facile pulizia (settore alimentare, farmaceutico, ecc.)
 Codifica
 I codici dei nostri prodotti seguono la seguente regola: M X - Ø - C
 M X = sigla modello Ø = diametro cilindro C = corsa standard
 Es: M X - 1040 = serie M X con Ø 10 corsa 40
 Sensore magnetico tipo SMAP

MX SERIES
 These cylinders, without edges, are particularly suitable when high reliability and easy cleaning are required. (Food and pharmaceutical sectors).
 The codes of our products follow these rule:
 MX - Ø - C MX = model Ø = bore size C = standard stroke
 Ex: MX - 1040 = MX series (Ø 10 - stroke 40)
 Magnetic sensor: SMAP Type

| ALESAGGIO | | CORSE STANDARD - STANDARD STROKES | | | | |
|------------|--|--|--|--|--|--|
| BORE SIZES | | | | | | |
| Ø 10 | | 25 - 50 - 75 - 100 - 125 - 150 - 175 - 200 - 225 - 250 - 275 - 300 | | | | |
| Ø 12 | | 25 - 50 - 75 - 100 - 125 - 150 - 175 - 200 - 225 - 250 - 275 - 300 | | | | |
| Ø 16 | | 25 - 50 - 75 - 100 - 125 - 150 - 175 - 200 - 225 - 250 - 275 - 300 | | | | |
| Ø 20 | | 25 - 50 - 75 - 100 - 125 - 150 - 175 - 200 - 225 - 250 - 275 - 300 | | | | |
| Ø 25 | | 25 - 50 - 75 - 100 - 125 - 150 - 175 - 200 - 225 - 250 - 275 - 300 | | | | |

| CORSIA | | ALESAGGIO - BORE SIZE | | | | |
|--------|--|-----------------------|------|------|------|--|
| STROKE | | Ø 10 | Ø 12 | Ø 16 | Ø 20 | |
| mm | | ☐ | ☐ | ☐ | ☐ | |
| 25 mm | | 1 | 1 | 1 | 1 | |
| 50 mm | | 1 | 1 | 1 | 1 | |
| 75 mm | | 1 | 1 | 1 | 1 | |
| 100 mm | | 1 | 1 | 1 | 1 | |
| 125 mm | | 1 | 1 | 1 | 1 | |
| 150 mm | | 1 | 1 | 1 | 1 | |
| 175 mm | | 1 | 1 | 1 | 1 | |
| 200 mm | | 1 | 1 | 1 | 1 | |
| 225 mm | | 1 | 1 | 1 | 1 | |
| 250 mm | | 1 | 1 | 1 | 1 | |
| 275 mm | | 1 | 1 | 1 | 1 | |
| 300 mm | | 1 | 1 | 1 | 1 | |
| +50 mm | | 1 | 1 | 1 | 1 | |

CILINDRI PNEUMATICI - PNEUMATIC CYLINDERS

CILINDRI STANDARD ALLUMINIO ISO 15552 - ISO 15552 ALUMINIUM STANDARD CYLINDERS

Cilindri standard ISO 15552 Ammortizzati D.E. Ø 32 - 125 mm
 Pressione di esercizio bar 1 ÷ 10
 Temperatura ambiente °C -15 ÷ 80
 Fluido aria filtrata, lubrificata o non
 Carnicia alluminio
 Testate alluminio
 Stelo acciaio inox AISI 303
 Pistone alluminio
 Guarnizioni gomma nitrilica

ISO 15552 Standard Cushioned Double Acting Cylinders Ø 32-125 mm
 Working pressure bar 1,5 ÷ 10
 Working temperature °C -20 ÷ 80
 Fluid Filtered air (lubricated or not)
 Barrel Aluminium
 Caps Die cast aluminium
 Piston rod Stainless Steel AISI 303
 Piston Aluminium
 Seals NBR



Serie C
 Codifica
 I codici dei nostri prodotti seguono la seguente regola:
 C - Ø - CS
 C = sigla modello Ø = diametro cilindro CS = corsa
 standardEs: C - 32125 = serie C con Ø 32 corsa 125
 Sensore magnetico tipo SMAP
 C SERIES
 The codes of our products follow these rule:
 C - Ø - CS
 C = model Ø = bore size CS = standard stroke
 Ex: C-32125 = C series (Ø 32 stroke 125)
 Magnetic Sensor: SMAP type

| CORSA STROKE mm | ALESAGGIO - BORE | | | | | | |
|-----------------------|------------------|------|------|------|------|-------|-------|
| | Ø 32 | Ø 40 | Ø 50 | Ø 63 | Ø 80 | Ø 100 | Ø 125 |
| 25 | 1 | 1 | 1 | 1 | 1 | 1 | 1 |
| 50 | 1 | 1 | 1 | 1 | 1 | 1 | 1 |
| 75 | 1 | 1 | 1 | 1 | 1 | 1 | 1 |
| 100 | 1 | 1 | 1 | 1 | 1 | 1 | 1 |
| 125 | 1 | 1 | 1 | 1 | 1 | 1 | 1 |
| 150 | 1 | 1 | 1 | 1 | 1 | 1 | 1 |
| 200 | 1 | 1 | 1 | 1 | 1 | 1 | 1 |
| 250 | 1 | 1 | 1 | 1 | 1 | 1 | 1 |
| 300 | 1 | 1 | 1 | 1 | 1 | 1 | 1 |
| 350 | 1 | 1 | 1 | 1 | 1 | 1 | 1 |
| 400 | 1 | 1 | 1 | 1 | 1 | 1 | 1 |
| 450 | 1 | 1 | 1 | 1 | 1 | 1 | 1 |
| 500 | 1 | 1 | 1 | 1 | 1 | 1 | 1 |
| 550 | 1 | 1 | 1 | 1 | 1 | 1 | 1 |
| 600 | 1 | 1 | 1 | 1 | 1 | 1 | 1 |
| 650 | 1 | 1 | 1 | 1 | 1 | 1 | 1 |
| 700 | 1 | 1 | 1 | 1 | 1 | 1 | 1 |
| 750 | 1 | 1 | 1 | 1 | 1 | 1 | 1 |
| 800 | 1 | 1 | 1 | 1 | 1 | 1 | 1 |
| 850 | 1 | 1 | 1 | 1 | 1 | 1 | 1 |
| 900 | 1 | 1 | 1 | 1 | 1 | 1 | 1 |
| 950 | 1 | 1 | 1 | 1 | 1 | 1 | 1 |
| 1000 | 1 | 1 | 1 | 1 | 1 | 1 | 1 |

KIT PER CILINDRI ALLUMINIO ISO 15552 - ISO 15552 ALUMINIUM STANDARD CYLINDERS MOUNTING KIT

| AMMORTIZZATI - CUSHIONED | | |
|--------------------------|------------------|---|
| COD | ALESAGGIO - BORE | ☒ |
| CDE 32 | Ø 32 | 1 |
| CDE 40 | Ø 40 | 1 |
| CDE 50 | Ø 50 | 1 |
| CDE 63 | Ø 63 | 1 |
| CDE 80 | Ø 80 | 1 |
| CDE 100 | Ø 100 | 1 |
| CDE 125 | Ø 125 | 1 |

| MAGNETICI AMMORTIZZATI - MAGNETIC CUSHIONED | | |
|---|------------------|---|
| COD | ALESAGGIO - BORE | ☒ |
| CDEM 32 | Ø 32 | 1 |
| CDEM 40 | Ø 40 | 1 |
| CDEM 50 | Ø 50 | 1 |
| CDEM 63 | Ø 63 | 1 |
| CDEM 80 | Ø 80 | 1 |
| CDEM 100 | Ø 100 | 1 |
| CDEM 125 | Ø 125 | 1 |

Kit cilindri a doppio effetto ammortizzati Ø 32 - 125 mm
 Pressione di esercizio bar 3 ÷ 10
 Temperatura ambiente °C -20 ÷ 80
 Testate alluminio presso fuso
 Pistone alluminio
 Guarnizioni gomma nitrilica
 Magnetico a richiesta

Mounting kit for double acting cushioned cylinders Ø 32 - 125 mm
 Working pressure bar 3 ÷ 10
 Working temperature °C -20 ÷ 80
 Caps Die cast Aluminium
 Piston Aluminium
 Seals NBR

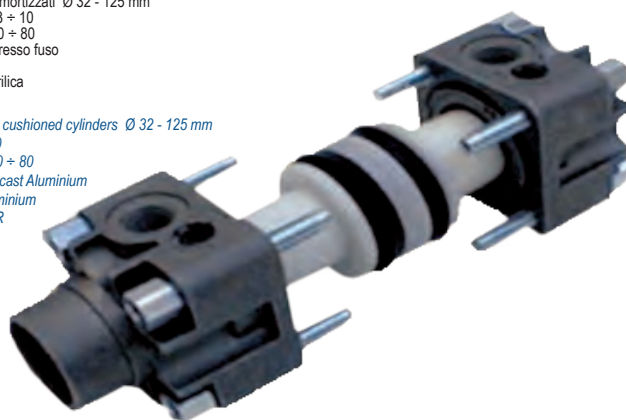

CILINDRI STANDARD INOX ISO 15552 - ISO 15552 INOX STANDARD CYLINDERS

Cilindri standard Inox ISO 15552 Ammortizzati D.E. Ø 32 - 125 mm
 Pressione di esercizio bar 1 ÷ 10
 Temperatura ambiente °C -15 ÷ 80
 Fluido Aria filtrata, lubrificata o non
 Camicia Alluminio - Acciaio Inox AISI 304
 Testate Alluminio - Acciaio Inox AISI 304
 Stelo Acciaio inox AISI 316
 Pistone Monoblocco
 Guarnizioni NBR - Viton

ISO 15552 Inox Standard Cushioned Double Acting Cylinders Ø 32-125 mm
 Working pressure bar 1 ÷ 10
 Working temperature °C -15 ÷ 80
 Fluid Filtered air (lubricated or not)
 Barrel Aluminium - Stainless steel AISI 304
 Caps Aluminium - Stainless steel AISI 304
 Piston rod Stainless Steel AISI 316
 Piston Monobloc
 Seals NBR - Viton



TX
 AISI 304 - 316

| CORSA STROKE mm | ALESAGGIO - BORE | | | | | | | | | | | | | | | | | | | | |
|-----------------------|------------------|---|----|------|---|----|------|---|----|------|---|----|------|---|----|-------|---|----|-------|---|----|
| | Ø 32 | | | Ø 40 | | | Ø 50 | | | Ø 63 | | | Ø 80 | | | Ø 100 | | | Ø 125 | | |
| | # | T | TX | # | T | TX | # | T | TX | # | T | TX | # | T | TX | # | T | TX | # | T | TX |
| 25 | 1 | 1 | 1 | 1 | 1 | 1 | 1 | 1 | 1 | 1 | 1 | 1 | 1 | 1 | 1 | 1 | 1 | 1 | 1 | 1 | 1 |
| 50 | 1 | 1 | 1 | 1 | 1 | 1 | 1 | 1 | 1 | 1 | 1 | 1 | 1 | 1 | 1 | 1 | 1 | 1 | 1 | 1 | 1 |
| 75 | 1 | 1 | 1 | 1 | 1 | 1 | 1 | 1 | 1 | 1 | 1 | 1 | 1 | 1 | 1 | 1 | 1 | 1 | 1 | 1 | 1 |
| 100 | 1 | 1 | 1 | 1 | 1 | 1 | 1 | 1 | 1 | 1 | 1 | 1 | 1 | 1 | 1 | 1 | 1 | 1 | 1 | 1 | 1 |
| 125 | 1 | 1 | 1 | 1 | 1 | 1 | 1 | 1 | 1 | 1 | 1 | 1 | 1 | 1 | 1 | 1 | 1 | 1 | 1 | 1 | 1 |
| 150 | 1 | 1 | 1 | 1 | 1 | 1 | 1 | 1 | 1 | 1 | 1 | 1 | 1 | 1 | 1 | 1 | 1 | 1 | 1 | 1 | 1 |
| 200 | 1 | 1 | 1 | 1 | 1 | 1 | 1 | 1 | 1 | 1 | 1 | 1 | 1 | 1 | 1 | 1 | 1 | 1 | 1 | 1 | 1 |
| 250 | 1 | 1 | 1 | 1 | 1 | 1 | 1 | 1 | 1 | 1 | 1 | 1 | 1 | 1 | 1 | 1 | 1 | 1 | 1 | 1 | 1 |
| 300 | 1 | 1 | 1 | 1 | 1 | 1 | 1 | 1 | 1 | 1 | 1 | 1 | 1 | 1 | 1 | 1 | 1 | 1 | 1 | 1 | 1 |
| 350 | 1 | 1 | 1 | 1 | 1 | 1 | 1 | 1 | 1 | 1 | 1 | 1 | 1 | 1 | 1 | 1 | 1 | 1 | 1 | 1 | 1 |
| 400 | 1 | 1 | 1 | 1 | 1 | 1 | 1 | 1 | 1 | 1 | 1 | 1 | 1 | 1 | 1 | 1 | 1 | 1 | 1 | 1 | 1 |
| 450 | 1 | 1 | 1 | 1 | 1 | 1 | 1 | 1 | 1 | 1 | 1 | 1 | 1 | 1 | 1 | 1 | 1 | 1 | 1 | 1 | 1 |
| 500 | 1 | 1 | 1 | 1 | 1 | 1 | 1 | 1 | 1 | 1 | 1 | 1 | 1 | 1 | 1 | 1 | 1 | 1 | 1 | 1 | 1 |
| 550 | 1 | 1 | 1 | 1 | 1 | 1 | 1 | 1 | 1 | 1 | 1 | 1 | 1 | 1 | 1 | 1 | 1 | 1 | 1 | 1 | 1 |
| 600 | 1 | 1 | 1 | 1 | 1 | 1 | 1 | 1 | 1 | 1 | 1 | 1 | 1 | 1 | 1 | 1 | 1 | 1 | 1 | 1 | 1 |
| 650 | 1 | 1 | 1 | 1 | 1 | 1 | 1 | 1 | 1 | 1 | 1 | 1 | 1 | 1 | 1 | 1 | 1 | 1 | 1 | 1 | 1 |
| 700 | 1 | 1 | 1 | 1 | 1 | 1 | 1 | 1 | 1 | 1 | 1 | 1 | 1 | 1 | 1 | 1 | 1 | 1 | 1 | 1 | 1 |
| 750 | 1 | 1 | 1 | 1 | 1 | 1 | 1 | 1 | 1 | 1 | 1 | 1 | 1 | 1 | 1 | 1 | 1 | 1 | 1 | 1 | 1 |
| 800 | 1 | 1 | 1 | 1 | 1 | 1 | 1 | 1 | 1 | 1 | 1 | 1 | 1 | 1 | 1 | 1 | 1 | 1 | 1 | 1 | 1 |
| 850 | 1 | 1 | 1 | 1 | 1 | 1 | 1 | 1 | 1 | 1 | 1 | 1 | 1 | 1 | 1 | 1 | 1 | 1 | 1 | 1 | 1 |
| 900 | 1 | 1 | 1 | 1 | 1 | 1 | 1 | 1 | 1 | 1 | 1 | 1 | 1 | 1 | 1 | 1 | 1 | 1 | 1 | 1 | 1 |

P 1 E T X

| VERSIONE - VERSION | |
|---------------------------------|--|
| Tubo estruso - Profile | |
| T Tiranti - Tie rod line | |
| TX Tutto Inox - Stainless steel | |

0 3 2

| ALESAGGIO - BORE | |
|------------------|--------------------------|
| 032 | |
| 040 | |
| 050 | |
| 063 | |
| 080 | |
| 100 | |
| 125 | |
| 160 | A richiesta - On request |
| 200 | A richiesta - On request |
| 250 | A richiesta - On request |
| 320 | A richiesta - On request |

M

| FUNZIONE - FUNCTION | |
|---------------------|--|
| M | Doppio effetto Double effect |
| F | Stelo passante ** Through piston rod and simple acting: on request ** |
| S | Semplice effetto ** Simple effect ** |

D

| GUARNIZIONI - SEALS | |
|---------------------|-----|
| D | NBR |
| S | FKM |

A

| PISTONE - PISTON | |
|------------------|------------------------------|
| A | Magnetico - Magnetic |
| S | Non magnetico - Non magnetic |

0 0 7 5

| CORSA - STROKE | |
|------------------------|--|
| Standard: 10 + 1000 mm | |

** Stelo passante e semplice effetto: a richiesta
 ** Through piston rod and simple effect: on request

PER TUTTE LE TIPOLOGIE
 E LE DIMENSIONI
 FOR ALL TYPES
 AND DIMENSIONS

= 1

VERSIONE IN ALLUMINIO - ALUMINIUM VERSION

Alluminio / Aluminium

T
Alluminio / Aluminium

CILINDRI CON STELO FORATO - PNEUMATIC CYLINDERS WITH HOLLOW ROD

ALESAGGIO Ø 25 - BORE SIZE Ø 25

Pressione d'esercizio Max. 10 Bar
 Temperatura d'esercizio - 35 °C ++ 80 °C
 Fluido Aria compressa lubrificata e non lubrificata
 Working pressure Max. 10 Bar
 Working temperature - 35 °C ++ 80 °C
 Fluid Filtered air (lubricated or not)

Testate Alluminio anodizzato
 Guarnizioni Poliuretano
 Tubo Acciaio Inox AISI 304
 Bronzina Bronzo sinterizzato
 O'ring NBR
 Pistone Alluminio
 Magnete Plastroferrite
 Asta Acciaio C45 cromato

Caps Anodized aluminium
 Seals Polyurethane
 Bazzel Stainless steel AISI 304
 Bushing Sintered bronze
 OR NBR
 Piston Aluminium
 Magnet Plastic-ferrite
 Rod C45 Chromed steel



Serie MCSF
 Codifica:
 I codici dei nostri prodotti seguono la seguente regola:
 MCSF - Ø - CS
 MCSF = Sigla modello Ø = diametro cilindro CS = corsa standard
 Esempio:
 MCSF-2525 = serie MCSF con Ø 25 e corsa 25
 MCSF Series
 The codes of our products follow these rule:
 MCSF - Ø - CS
 MCSF = model Ø = bore size CS = standard stroke
 Example:
 MCSF-2525 = MCSF Series (Ø 25 - stroke 25)

VERSIONE ANTI ROTAZIONE A RICHIESTA (SERIE MCSF-A)
 ANTI-ROTATION VERSION ON REQUEST (MCSF-A SERIES)

ALESAGGIO Ø 32 - 40 - 50 - 63 - BORE SIZES Ø 32 - 40 - 50 - 63

Pressione d'esercizio Max. 10 Bar
 Temperatura d'esercizio - 35 °C ++ 80 °C
 Fluido Aria compressa lubrificata e non lubrificata
 Working pressure Max. 10 Bar
 Working temperature - 35 °C ++ 80 °C
 Fluid Filtered air (lubricated or not)

Testate Alluminio pressofuso
 Guarnizioni Poliuretano
 Tubo Alluminio anodizzato
 Bronzina Bronzo sinterizzato
 O'ring NBR
 Pistone Alluminio pressofuso
 Magnete Plastroferrite
 Asta Acciaio C45 cromato

Caps Anodized aluminium
 Seals Polyurethane
 Bazzel Stainless steel AISI 304
 Bushing Sintered bronze
 OR NBR
 Piston Aluminium
 Magnet Plastic-ferrite
 Rod C45 Chromed steel



Serie CSF
 Codifica:
 I codici dei nostri prodotti seguono la seguente regola:
 CSF - Ø - CS
 CSF = Sigla modello Ø = diametro cilindro CS = corsa standard
 Esempio:
 CSF-3225 = serie CSF con Ø 32 e corsa 25
 CSF Series
 The codes of our products follow these rule:
 CSF - Ø - CS
 CSF = model Ø = bore size CS = standard stroke
 Example:
 CSF-3225 = CSF Series (Ø 32 - stroke 25)

ALESAGGIO - BORE SIZE

| CORSIA STROKE mm | COD | Ø 25 | | | | | Ø 32 | | | | | Ø 40 | | | | | Ø 50 | | | | | Ø 63 | | | | |
|------------------------|------------|----------------|----------|----------------|---------|----------------|------|----------------|------|----------------|------|----------------|------|----------------|------|----------------|------|----------------|------|----------------|------|------|--|--|--|--|
| | | ANTI ROTAZIONE | Ø 25 | ANTI ROTAZIONE | Ø 25 | ANTI ROTAZIONE | Ø 32 | ANTI ROTAZIONE | Ø 32 | ANTI ROTAZIONE | Ø 40 | ANTI ROTAZIONE | Ø 40 | ANTI ROTAZIONE | Ø 50 | ANTI ROTAZIONE | Ø 50 | ANTI ROTAZIONE | Ø 63 | ANTI ROTAZIONE | Ø 63 | | | | | |
| 25 | MCSF-A-25 | 1 | MCSF-25 | 1 | CSF-25 | 1 | 1 | 1 | 1 | 1 | 1 | 1 | 1 | 1 | 1 | 1 | 1 | 1 | 1 | 1 | | | | | | |
| 50 | MCSF-A-50 | 1 | MCSF-50 | 1 | CSF-50 | 1 | 1 | 1 | 1 | 1 | 1 | 1 | 1 | 1 | 1 | 1 | 1 | 1 | 1 | 1 | | | | | | |
| 75 | MCSF-A-75 | 1 | MCSF-75 | 1 | CSF-75 | 1 | 1 | 1 | 1 | 1 | 1 | 1 | 1 | 1 | 1 | 1 | 1 | 1 | 1 | 1 | | | | | | |
| 100 | MCSF-A-100 | 1 | MCSF-100 | 1 | CSF-100 | 1 | 1 | 1 | 1 | 1 | 1 | 1 | 1 | 1 | 1 | 1 | 1 | 1 | 1 | 1 | | | | | | |
| 125 | MCSF-A-125 | 1 | MCSF-125 | 1 | CSF-125 | 1 | 1 | 1 | 1 | 1 | 1 | 1 | 1 | 1 | 1 | 1 | 1 | 1 | 1 | 1 | | | | | | |
| 150 | MCSF-A-150 | 1 | MCSF-150 | 1 | CSF-150 | 1 | 1 | 1 | 1 | 1 | 1 | 1 | 1 | 1 | 1 | 1 | 1 | 1 | 1 | 1 | | | | | | |
| 175 | MCSF-A-175 | 1 | MCSF-175 | 1 | CSF-175 | 1 | 1 | 1 | 1 | 1 | 1 | 1 | 1 | 1 | 1 | 1 | 1 | 1 | 1 | 1 | | | | | | |
| 200 | MCSF-A-200 | 1 | MCSF-200 | 1 | CSF-200 | 1 | 1 | 1 | 1 | 1 | 1 | 1 | 1 | 1 | 1 | 1 | 1 | 1 | 1 | 1 | | | | | | |
| 225 | MCSF-A-225 | 1 | MCSF-225 | 1 | CSF-225 | 1 | 1 | 1 | 1 | 1 | 1 | 1 | 1 | 1 | 1 | 1 | 1 | 1 | 1 | 1 | | | | | | |
| 250 | MCSF-A-250 | 1 | MCSF-250 | 1 | CSF-250 | 1 | 1 | 1 | 1 | 1 | 1 | 1 | 1 | 1 | 1 | 1 | 1 | 1 | 1 | 1 | | | | | | |
| 275 | MCSF-A-275 | 1 | MCSF-275 | 1 | CSF-275 | 1 | 1 | 1 | 1 | 1 | 1 | 1 | 1 | 1 | 1 | 1 | 1 | 1 | 1 | 1 | | | | | | |
| 300 | MCSF-A-300 | 1 | MCSF-300 | 1 | CSF-300 | 1 | 1 | 1 | 1 | 1 | 1 | 1 | 1 | 1 | 1 | 1 | 1 | 1 | 1 | 1 | | | | | | |
| 325 | MCSF-A-225 | 1 | MCSF-225 | 1 | CSF-225 | 1 | 1 | 1 | 1 | 1 | 1 | 1 | 1 | 1 | 1 | 1 | 1 | 1 | 1 | 1 | | | | | | |

N.B. PER GLI ALESAGGI Ø 40 - 50 - 63 IL PREZZO DI LISTINO VIENE FORNITO SU RICHIESTA - FOR BORE SIZES Ø 40 - 50 - 63 PRICE LIST ON REQUEST.

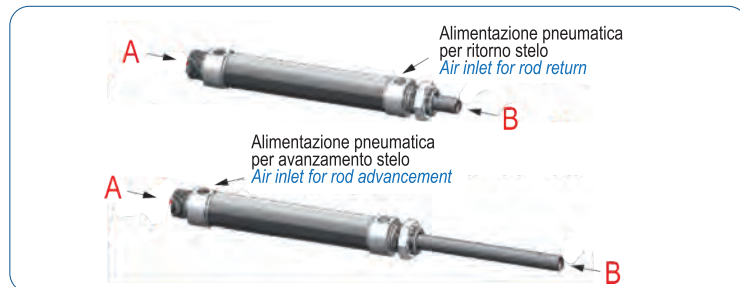

I cilindri con stelo forato (ad asta cava) hanno la caratteristica di permettere il passaggio dell'aria dalla zona posteriore (A) alla zona anteriore (B) consentendo il montaggio diretto sullo stelo di eventuali accessori pneumatici. Questo risulta particolarmente utile nel caso di utilizzo nel settore del vuoto.

Pneumatic cylinders with hollow rod allow the passage of air from the rear area A to the front area B, allowing direct mounting for any pneumatic device on the rod. This is particularly useful when used in the vacuum sector.

UNITÀ DI GUIDA - GUIDING UNITS FOR CYLINDERS



UNITÀ DI GUIDA TIPO H CON BOCCOLE DI SCORRIMENTO - H PROFILE GUIDING UNIT WITH SINTERED BRONZE GUIDE

| CORSA | Ø 16 | Ø 20 - 25 | Ø 32 | Ø 40 | Ø 50 | Ø 63 | Ø 80 | Ø 100 |
|---------------|------|-----------|------|------|------|------|------|-------|
| STROKE | 🛒 | 🛒 | 🛒 | 🛒 | 🛒 | 🛒 | 🛒 | 🛒 |
| 50 | 1 | 1 | 1 | 1 | 1 | 1 | 1 | 1 |
| 100 | 1 | 1 | 1 | 1 | 1 | 1 | 1 | 1 |
| 160 | 1 | 1 | 1 | 1 | 1 | 1 | 1 | 1 |
| 200 | 1 | 1 | 1 | 1 | 1 | 1 | 1 | 1 |
| 250 | 1 | 1 | 1 | 1 | 1 | 1 | 1 | 1 |
| 320 | 1 | 1 | 1 | 1 | 1 | 1 | 1 | 1 |
| 400 | 1 | 1 | 1 | 1 | 1 | 1 | 1 | 1 |
| 500 | 1 | 1 | 1 | 1 | 1 | 1 | 1 | 1 |

Materiale:
Alluminio di alta qualità AG3 (ENAC-51100) adatto per l'industria chimica ed alimentare.
Material:
High quality Aluminium AG3 (ENAC-51100) suitable for chemical and food industry.



UNITÀ DI GUIDA TIPO H CON MANICOTTO A SFERE - H PROFILE GUIDING UNIT WITH RECIRCULATING BALL SLEEVES

| CORSA | Ø 16 | Ø 20 - 25 | Ø 32 | Ø 40 | Ø 50 | Ø 63 | Ø 80 | Ø 100 |
|---------------|------|-----------|------|------|------|------|------|-------|
| STROKE | 🛒 | 🛒 | 🛒 | 🛒 | 🛒 | 🛒 | 🛒 | 🛒 |
| 50 | 1 | 1 | 1 | 1 | 1 | 1 | 1 | 1 |
| 100 | 1 | 1 | 1 | 1 | 1 | 1 | 1 | 1 |
| 160 | 1 | 1 | 1 | 1 | 1 | 1 | 1 | 1 |
| 200 | 1 | 1 | 1 | 1 | 1 | 1 | 1 | 1 |
| 250 | 1 | 1 | 1 | 1 | 1 | 1 | 1 | 1 |
| 320 | 1 | 1 | 1 | 1 | 1 | 1 | 1 | 1 |
| 400 | 1 | 1 | 1 | 1 | 1 | 1 | 1 | 1 |
| 500 | 1 | 1 | 1 | 1 | 1 | 1 | 1 | 1 |

Materiale:
Alluminio di alta qualità AG3 (ENAC-51100) adatto per l'industria chimica ed alimentare.
Material:
High quality Aluminium AG3 (ENAC-51100) suitable for chemical and food industry.



UNITÀ DI GUIDA TIPO U CON BOCCOLE DI SCORRIMENTO - U PROFILE GUIDING UNIT WITH SINTERED BRONZE GUIDE

| CORSA | Ø 16 | Ø 20 - 25 | Ø 32 | Ø 40 | Ø 50 | Ø 63 | Ø 80 | Ø 100 |
|---------------|------|-----------|------|------|------|------|------|-------|
| STROKE | 🛒 | 🛒 | 🛒 | 🛒 | 🛒 | 🛒 | 🛒 | 🛒 |
| 50 | 1 | 1 | 1 | 1 | 1 | 1 | 1 | 1 |
| 100 | 1 | 1 | 1 | 1 | 1 | 1 | 1 | 1 |
| 160 | 1 | 1 | 1 | 1 | 1 | 1 | 1 | 1 |
| 200 | 1 | 1 | 1 | 1 | 1 | 1 | 1 | 1 |
| 250 | 1 | 1 | 1 | 1 | 1 | 1 | 1 | 1 |
| 320 | 1 | 1 | 1 | 1 | 1 | 1 | 1 | 1 |
| 400 | 1 | 1 | 1 | 1 | 1 | 1 | 1 | 1 |
| 500 | 1 | 1 | 1 | 1 | 1 | 1 | 1 | 1 |

Materiale:
Alluminio di alta qualità AG3 (ENAC-51100) adatto per l'industria chimica ed alimentare.
Material:
High quality Aluminium AG3 (ENAC-51100) suitable for chemical and food industry.



KIT UNITÀ DI GUIDA TIPO H - H PROFILE GUIDING KIT **KIT UNITÀ DI GUIDA TIPO U - U PROFILE GUIDING KIT**

| Ø CILINDRO CYLINDER | CON BOCCOLE DI SCORRIMENTO WITH SINTERED BRONZE GUIDE | CON MANICOTTO A SFERE WITH RECIRCULATING BALL SLEEVES | Ø CILINDRO CYLINDER | CON BOCCOLE DI SCORRIMENTO WITH SINTERED BRONZE GUIDE |
|------------------------|--|--|------------------------|--|
| 16 | 🛒 | 🛒 | 16 | 🛒 |
| 20 | 1 | 1 | 20 | 1 |
| 25 | 1 | 1 | 25 | 1 |
| 32 | 1 | 1 | 32 | 1 |
| 40 | 1 | 1 | 40 | 1 |
| 50 | 1 | 1 | 50 | 1 |
| 63 | 1 | 1 | 63 | 1 |
| 80 | 1 | 1 | 80 | 1 |
| 100 | 1 | 1 | 100 | 1 |

Materiale:
Alluminio di alta qualità AG3 (ENAC-51100) adatto per l'industria chimica ed industriale.
Material:
High quality Aluminium AG3 (ENAC-51100) suitable for chemical and food industry.

PREZZO AL METRO - PRICE PER METER

| Ø CILINDRO CYLINDER | BARRA CROMATA - CHROME BAR | | BARRA TEMPRATA - HARDENED BAR | |
|------------------------|----------------------------|--|-------------------------------|--|
| | Ø A | CON BOCCOLE DI SCORRIMENTO WITH SINTERED BRONZE GUIDE | Ø A | CON MANICOTTO A SFERE WITH RECIRCULATING BALL SLEEVES |
| | | 🛒 | | 🛒 |
| 16 | 10 | 1 | 8 | 1 |
| 20 | 12 | 1 | 10 | 1 |
| 25 | 12 | 1 | 10 | 1 |
| 32 | 16 | 1 | 12 | 1 |
| 40 | 16 | 1 | 16 | 1 |
| 50 | 20 | 1 | 20 | 1 |
| 63 | 20 | 1 | 20 | 1 |
| 80 | 25 | 1 | 25 | 1 |
| 100 | 25 | 1 | 25 | 1 |

L: 1000 MM

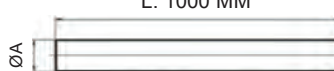

VERSIONE INOX SU RICHIESTA - STAINLESS STEEL ON REQUEST

CILINDRI SENZA STELO MAGNETICI - *MAGNETIC RODLESS CYLINDERS*

CSS - M0

ALESAGGIO - BORE SIZE

| | 10 | 15 | 20 | 25 | 32 | 40 |
|-----|----|----|----|----|----|----|
| mm | ☒ | ☒ | ☒ | ☒ | ☒ | ☒ |
| 100 | 1 | 1 | 1 | 1 | 1 | 1 |
| 200 | 1 | 1 | 1 | 1 | 1 | 1 |
| 300 | 1 | 1 | 1 | 1 | 1 | 1 |
| 400 | 1 | 1 | 1 | 1 | 1 | 1 |
| 500 | 1 | 1 | 1 | 1 | 1 | 1 |



CSS-0

CARATTERISTICHE:
 Cilindro senza stele ad accoppiamento magnetico
 Versione base
 Massima pressione di esercizio: 7 bar
 VERSIONI SPECIALI A RICHIESTA

FEATURES:
Magnetic rodless cylinder
 Basic type
 Maximum operating pressure: 7 Bar
 SPECIAL VERSIONS ON REQUEST

CSS - M1

ALESAGGIO - BORE SIZE

| | 10 | 15 | 20 | 25 | 32 | 40 |
|-----|----|----|----|----|----|----|
| mm | ☒ | ☒ | ☒ | ☒ | ☒ | ☒ |
| 100 | 1 | 1 | 1 | 1 | 1 | 1 |
| 200 | 1 | 1 | 1 | 1 | 1 | 1 |
| 300 | 1 | 1 | 1 | 1 | 1 | 1 |
| 400 | 1 | 1 | 1 | 1 | 1 | 1 |
| 500 | 1 | 1 | 1 | 1 | 1 | 1 |



CSS-1

CARATTERISTICHE:
 Cilindro senza stele ad accoppiamento magnetico
 Versione diretta
 Massima pressione di esercizio: 7 bar
 VERSIONI SPECIALI A RICHIESTA

FEATURES:
Magnetic rodless cylinder
 Direct type
 Maximum operating pressure: 7 Bar
 SPECIAL VERSIONS ON REQUEST

CSS - M2

ALESAGGIO - BORE SIZE

| | 10 | 15 | 20 | 25 | 32 | 40 |
|-----|----|----|----|----|----|----|
| mm | ☒ | ☒ | ☒ | ☒ | ☒ | ☒ |
| 100 | 1 | 1 | 1 | 1 | 1 | 1 |
| 200 | 1 | 1 | 1 | 1 | 1 | 1 |
| 300 | 1 | 1 | 1 | 1 | 1 | 1 |
| 400 | 1 | 1 | 1 | 1 | 1 | 1 |
| 500 | 1 | 1 | 1 | 1 | 1 | 1 |



CSS-2

CARATTERISTICHE:
 Cilindro senza stele ad accoppiamento magnetico
 Boccia scorrevole
 Massima pressione di esercizio: 7 bar
 SENSORE MAGNETICO HX - 31
 VERSIONI SPECIALI A RICHIESTA

FEATURES:
Magnetic rodless cylinder
 Slide bushing type
 Maximum operating pressure: 7 Bar
 Magnetic sensor: HX-31 Type
 SPECIAL VERSIONS ON REQUEST

CSS - M3

ALESAGGIO - BORE SIZE

| | 10 | 15 | 20 | 25 | 32 | 40 |
|-----|----|----|----|----|----|----|
| mm | ☒ | ☒ | ☒ | ☒ | ☒ | ☒ |
| 100 | 1 | 1 | 1 | 1 | 1 | 1 |
| 200 | 1 | 1 | 1 | 1 | 1 | 1 |
| 300 | 1 | 1 | 1 | 1 | 1 | 1 |
| 400 | 1 | 1 | 1 | 1 | 1 | 1 |
| 500 | 1 | 1 | 1 | 1 | 1 | 1 |



CSS-3

CARATTERISTICHE:
 Cilindro senza stele ad accoppiamento magnetico
 Versione con cuscinetto a sfera
 Massima pressione di esercizio: 7 bar
 SENSORE MAGNETICO HX - 31
 VERSIONI SPECIALI A RICHIESTA

FEATURES:
Magnetic rodless cylinder
 Ball Bearing type
 Maximum operating pressure: 7 Bar
 Magnetic sensor: HX-31 Type
 SPECIAL VERSIONS ON REQUEST

CSS - P0

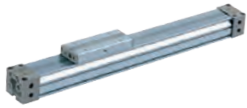

CARATTERISTICHE:
 Cilindro senza stelo pneumatico
 Versione base
 Massima pressione di esercizio: 8 bar
 VERSIONI SPECIALI A RICHIESTA
 SENSORE TIPO AL - 30
FEATURES:
 Pneumatic Rodless Cylinder
 Basic Type
 Maximum operating pressure: 8 bar
 Magnetic sensor: AL-30 Type
 SPECIAL TYPE: ON REQUEST

| mm | ALESAGGIO - BORE SIZE | | | | | |
|------------|-----------------------|----|----|----|----|----|
| | 16 | 20 | 25 | 32 | 40 | 50 |
| 1 - 100 | 1 | 1 | 1 | 1 | 1 | 1 |
| 101 - 200 | 1 | 1 | 1 | 1 | 1 | 1 |
| 201 - 300 | 1 | 1 | 1 | 1 | 1 | 1 |
| 301 - 400 | 1 | 1 | 1 | 1 | 1 | 1 |
| 401 - 500 | 1 | 1 | 1 | 1 | 1 | 1 |
| 501 - 600 | 1 | 1 | 1 | 1 | 1 | 1 |
| 601 - 700 | 1 | 1 | 1 | 1 | 1 | 1 |
| 701 - 800 | 1 | 1 | 1 | 1 | 1 | 1 |
| 801 - 900 | 1 | 1 | 1 | 1 | 1 | 1 |
| 901 - 1000 | 1 | 1 | 1 | 1 | 1 | 1 |

CSS - P1

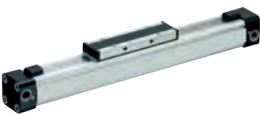

CARATTERISTICHE:
 Cilindro senza stelo pneumatico
 Versione per servizi pesanti
 Massima pressione di esercizio: 8 bar
 VERSIONI SPECIALI A RICHIESTA
 SENSORE TIPO AL - 30
FEATURES:
 Pneumatic Rodless Cylinder
 Heavy Duty Type
 Maximum operating pressure: 8 bar
 Magnetic sensor: AL-30 Type
 SPECIAL TYPE: ON REQUEST

| mm | ALESAGGIO - BORE SIZE | | |
|------------|-----------------------|----|----|
| | 20 | 32 | 40 |
| 1 - 100 | 1 | 1 | 1 |
| 101 - 200 | 1 | 1 | 1 |
| 201 - 300 | 1 | 1 | 1 |
| 301 - 400 | 1 | 1 | 1 |
| 401 - 500 | 1 | 1 | 1 |
| 501 - 600 | 1 | 1 | 1 |
| 601 - 700 | 1 | 1 | 1 |
| 701 - 800 | 1 | 1 | 1 |
| 801 - 900 | 1 | 1 | 1 |
| 901 - 1000 | 1 | 1 | 1 |

CSS - P2



CARATTERISTICHE:
 Cilindro senza stelo pneumatico
 Versione con guida lineare incorporata
 Massima pressione di esercizio: 8 bar
 VERSIONI SPECIALI A RICHIESTA
 SENSORE TIPO AL - 30
FEATURES:
 Pneumatic Rodless Cylinder
 Linear Guide Type
 Maximum operating pressure: 8 bar
 Magnetic sensor: AL-30 Type
 SPECIAL TYPE: ON REQUEST

| mm | ALESAGGIO - BORE SIZE | | |
|------------|-----------------------|----|----|
| | 16 | 20 | 25 |
| 1 - 100 | 1 | 1 | 1 |
| 101 - 200 | 1 | 1 | 1 |
| 201 - 300 | 1 | 1 | 1 |
| 301 - 400 | 1 | 1 | 1 |
| 401 - 500 | 1 | 1 | 1 |
| 501 - 600 | 1 | 1 | 1 |
| 601 - 700 | 1 | 1 | 1 |
| 701 - 800 | 1 | 1 | 1 |
| 801 - 900 | 1 | 1 | 1 |
| 901 - 1000 | 1 | 1 | 1 |

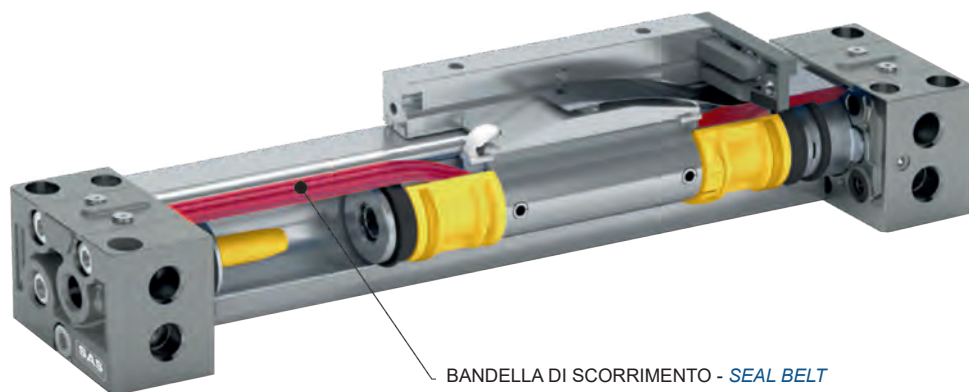

BANDELLA DI SCORRIMENTO - SEAL BELT

CILINDRI SENZA STELO PNEUMATICI EUROPEAN DESIGN - EUROPEAN DESIGN TYPE RODLESS CYLINDERS

SZS



| mm | ALESAGGIO - BORE SIZE | | | | | |
|------------|-----------------------|----|----|----|----|----|
| | 18 | 25 | 32 | 40 | 50 | 63 |
| 1 - 100 | 1 | 1 | 1 | 1 | 1 | 1 |
| 101 - 200 | 1 | 1 | 1 | 1 | 1 | 1 |
| 201 - 300 | 1 | 1 | 1 | 1 | 1 | 1 |
| 310 - 400 | 1 | 1 | 1 | 1 | 1 | 1 |
| 401 - 500 | 1 | 1 | 1 | 1 | 1 | 1 |
| 501 - 600 | 1 | 1 | 1 | 1 | 1 | 1 |
| 601 - 700 | 1 | 1 | 1 | 1 | 1 | 1 |
| 701 - 800 | 1 | 1 | 1 | 1 | 1 | 1 |
| 801 - 900 | 1 | 1 | 1 | 1 | 1 | 1 |
| 901 - 1000 | 1 | 1 | 1 | 1 | 1 | 1 |

CARATTERISTICHE:
 Cilindro senza stelo pneumatico
 Carrello standard
 Massima pressione di esercizio: 8 bar
 VERSIONI SPECIALI A RICHIESTA
 SENSORE TIPO T o TIPO C
 con connettore M8 o 1 - 2 mt. di cavo

FEATURES:
 Pneumatic rodless cylinder
 Standard carriage
 Maximum operating pressure: 8 bar
 SPECIAL VERSIONS ON REQUEST
 TYPE T or TYPE C SENSOR
 with M8 or 1 - 2 mt connector of cable

SZK



| mm | ALESAGGIO - BORE SIZE | | | | | |
|------------|-----------------------|----|----|----|----|----|
| | 18 | 25 | 32 | 40 | 50 | 63 |
| 1 - 100 | 1 | 1 | 1 | 1 | 1 | 1 |
| 101 - 200 | 1 | 1 | 1 | 1 | 1 | 1 |
| 201 - 300 | 1 | 1 | 1 | 1 | 1 | 1 |
| 310 - 400 | 1 | 1 | 1 | 1 | 1 | 1 |
| 401 - 500 | 1 | 1 | 1 | 1 | 1 | 1 |
| 501 - 600 | 1 | 1 | 1 | 1 | 1 | 1 |
| 601 - 700 | 1 | 1 | 1 | 1 | 1 | 1 |
| 701 - 800 | 1 | 1 | 1 | 1 | 1 | 1 |
| 801 - 900 | 1 | 1 | 1 | 1 | 1 | 1 |
| 901 - 1000 | 1 | 1 | 1 | 1 | 1 | 1 |

CARATTERISTICHE:
 Cilindro senza stelo pneumatico
 Carrello kompakt
 Massima pressione di esercizio: 8 bar
 VERSIONI SPECIALI A RICHIESTA
 SENSORE TIPO T o TIPO C
 con connettore M8 o 1 - 2 mt. di cavo

FEATURES:
 Pneumatic rodless cylinder
 Kompact carriage
 Maximum operating pressure: 8 bar
 SPECIAL VERSIONS ON REQUEST
 TYPE T or TYPE C SENSOR
 with M8 or 1 - 2 mt connector of cable

SZF



| mm | ALESAGGIO - BORE SIZE | | | | | |
|------------|-----------------------|----|----|----|----|----|
| | 18 | 25 | 32 | 40 | 50 | 63 |
| 1 - 100 | 1 | 1 | 1 | 1 | 1 | 1 |
| 101 - 200 | 1 | 1 | 1 | 1 | 1 | 1 |
| 201 - 300 | 1 | 1 | 1 | 1 | 1 | 1 |
| 310 - 400 | 1 | 1 | 1 | 1 | 1 | 1 |
| 401 - 500 | 1 | 1 | 1 | 1 | 1 | 1 |
| 501 - 600 | 1 | 1 | 1 | 1 | 1 | 1 |
| 601 - 700 | 1 | 1 | 1 | 1 | 1 | 1 |
| 701 - 800 | 1 | 1 | 1 | 1 | 1 | 1 |
| 801 - 900 | 1 | 1 | 1 | 1 | 1 | 1 |
| 901 - 1000 | 1 | 1 | 1 | 1 | 1 | 1 |

CARATTERISTICHE:
 Cilindro senza stelo pneumatico
 Carrello standard con guida a ricircolo di sfere su un lato
 Massima pressione di esercizio: 8 bar
 VERSIONI SPECIALI A RICHIESTA
 SENSORE TIPO T o TIPO C
 con connettore M8 o 1 - 2 mt. di cavo

FEATURES:
 Pneumatic rodless cylinder
 Standard carriage with recirculation guide of spheres on one side
 Maximum operating pressure: 8 bar
 SPECIAL VERSIONS ON REQUEST
 TYPE T or TYPE C SENSOR
 with M8 or 1 - 2 mt connector of cable

SZFK



| mm | ALESAGGIO - BORE SIZE | | | | | |
|------------|-----------------------|----|----|----|----|----|
| | 18 | 25 | 32 | 40 | 50 | 63 |
| 1 - 100 | 1 | 1 | 1 | 1 | 1 | 1 |
| 101 - 200 | 1 | 1 | 1 | 1 | 1 | 1 |
| 201 - 300 | 1 | 1 | 1 | 1 | 1 | 1 |
| 310 - 400 | 1 | 1 | 1 | 1 | 1 | 1 |
| 401 - 500 | 1 | 1 | 1 | 1 | 1 | 1 |
| 501 - 600 | 1 | 1 | 1 | 1 | 1 | 1 |
| 601 - 700 | 1 | 1 | 1 | 1 | 1 | 1 |
| 701 - 800 | 1 | 1 | 1 | 1 | 1 | 1 |
| 801 - 900 | 1 | 1 | 1 | 1 | 1 | 1 |
| 901 - 1000 | 1 | 1 | 1 | 1 | 1 | 1 |

CARATTERISTICHE:
 Cilindro senza stelo pneumatico
 Carrello standard con guida a ricircolo di sfere su un lato
 Massima pressione di esercizio: 8 bar
 VERSIONI SPECIALI A RICHIESTA
 SENSORE TIPO T o TIPO C
 con connettore M8 o 1 - 2 mt. di cavo

FEATURES:
 Pneumatic rodless cylinder
 Standard carriage with recirculation guide of spheres on one side
 Maximum operating pressure: 8 bar
 SPECIAL VERSIONS ON REQUEST
 TYPE T or TYPE C SENSOR
 with M8 or 1 - 2 mt connector of cable

SZFF



| mm | ALESAGGIO - BORE SIZE | | | | | |
|------------|-----------------------|----|----|----|----|----|
| | 18 | 25 | 32 | 40 | 50 | 63 |
| 1 - 100 | 1 | 1 | 1 | 1 | 1 | 1 |
| 101 - 200 | 1 | 1 | 1 | 1 | 1 | 1 |
| 201 - 300 | 1 | 1 | 1 | 1 | 1 | 1 |
| 310 - 400 | 1 | 1 | 1 | 1 | 1 | 1 |
| 401 - 500 | 1 | 1 | 1 | 1 | 1 | 1 |
| 501 - 600 | 1 | 1 | 1 | 1 | 1 | 1 |
| 601 - 700 | 1 | 1 | 1 | 1 | 1 | 1 |
| 701 - 800 | 1 | 1 | 1 | 1 | 1 | 1 |
| 801 - 900 | 1 | 1 | 1 | 1 | 1 | 1 |
| 901 - 1000 | 1 | 1 | 1 | 1 | 1 | 1 |

CARATTERISTICHE:
 Cilindro senza stelo pneumatico
 Carrello standard con guida a ricircolo di sfere su entrambi i lati
 Massima pressione di esercizio: 8 bar
 VERSIONI SPECIALI A RICHIESTA
 SENSORE TIPO T o TIPO C
 con connettore M8 o 1 - 2 mt. di cavo

FEATURES:
 Pneumatic rodless cylinder
 Standard carriage with recirculation guide of spheres on both sides
 Maximum operating pressure: 8 bar
 VERSIONI SPECIALI A RICHIESTA
 TYPE T or TYPE C SENSOR
 with M8 or 1 - 2 mt connector of cable

DECELERATORI SERIE AC - SHOCK ABSORBERS - AC SERIES

COME ORDINARE - HOW TO ORDER



AC

25

25

1



AC: Tipo senza regolazione
ACD: Doppia regolazione
con ammortizzo

AC: Without adjustable type
ACD: Double adjustment
with cushion

Diametro
Bore Size

Corsa
Stroke

1: Alta velocità di impatto
2: Media velocità di impatto
3: Bassa velocità di impatto

1: High impact speed
2: Medium impact speed
3: Low impact speed

Bianco: con cappuccio
N: senza cappuccio
White: with hood
N: without hood

Esempio: AC 2525-1 - Tipo non regolabile - Alta velocità di impatto - Con cappuccio
Example: AC 2525-1 - Without adjustable type - High impact speed - With hood

| COD | CORSA STROKE | ENERGIA MAX ASSORBIBILE PER CICLO MAX. ASSORBABLE ENERGY PER CYCLE (NM) | ENERGIA MAX ASSORBIBILE PER ORA MAX. ASSORBABLE ENERGY PER HOUR (NM/hr) | PESO MAX MAX WEIGHT (Kg) | MAX VELOCITÀ DI IMPATTO MAX IMPACT SPEED (m/s) | TEMPERATURA DI ESERCIZIO WORKING TEMPERATURE (°C) | 🛒 |
|------------|-----------------|--|--|--------------------------------|--|---|---|
| AC-0806-1 | 6 | 2 | 7200 | 0,5 | 2,0 | - 10 ~ + 85 | 1 |
| AC-0806-2 | 6 | 2 | 7200 | 2,0 | 1,0 | - 10 ~ + 85 | 1 |
| AC-0806-3 | 6 | 2 | 7200 | 6,0 | 0,5 | - 10 ~ + 85 | 1 |
| AC-1005-1 | 5 | 3 | 10800 | 1 | 3,0 | - 10 ~ + 85 | 1 |
| AC-1005-2 | 5 | 3 | 10800 | 3 | 1,5 | - 10 ~ + 85 | 1 |
| AC-1005-3 | 5 | 3 | 10800 | 7 | 0,8 | - 10 ~ + 85 | 1 |
| AC-1008-1 | 8 | 4 | 14400 | 2 | 3,0 | - 10 ~ + 85 | 1 |
| AC-1008-2 | 8 | 4 | 14400 | 4 | 1,5 | - 10 ~ + 85 | 1 |
| AC-1008-3 | 8 | 4 | 14400 | 9 | 0,8 | - 10 ~ + 85 | 1 |
| AC-1210-1 | 10 | 5 | 18000 | 5 | 3,0 | - 10 ~ + 85 | 1 |
| AC-1210-2 | 10 | 5 | 18000 | 10 | 1,5 | - 10 ~ + 85 | 1 |
| AC-1210-3 | 10 | 5 | 18000 | 30 | 0,8 | - 10 ~ + 85 | 1 |
| AC-1412-1 | 12 | 15 | 36000 | 8 | 3,0 | - 10 ~ + 85 | 1 |
| AC-1412-2 | 12 | 15 | 36000 | 50 | 1,5 | - 10 ~ + 85 | 1 |
| AC-1412-3 | 12 | 15 | 36000 | 100 | 0,8 | - 10 ~ + 85 | 1 |
| AC-1416-1 | 16 | 20 | 40000 | 10 | 3,0 | - 10 ~ + 85 | 1 |
| AC-1416-1 | 16 | 20 | 40000 | 70 | 1,5 | - 10 ~ + 85 | 1 |
| AC-1416-1 | 16 | 20 | 40000 | 150 | 0,8 | - 10 ~ + 85 | 1 |
| AC-1420-1 | 20 | 25 | 48000 | 12 | 3,0 | - 10 ~ + 85 | 1 |
| AC-1420-2 | 20 | 25 | 48000 | 80 | 1,5 | - 10 ~ + 85 | 1 |
| AC-1420-3 | 20 | 25 | 48000 | 160 | 0,8 | - 10 ~ + 85 | 1 |
| AC-2020-1 | 20 | 40 | 48000 | 30 | 3,5 | - 10 ~ + 85 | 1 |
| AC-2020-2 | 20 | 40 | 48000 | 200 | 2,0 | - 10 ~ + 85 | 1 |
| AC-2020-3 | 20 | 40 | 48000 | 700 | 1,0 | - 10 ~ + 85 | 1 |
| AC-2030-1 | 30 | 50 | 54000 | 30 | 3,5 | - 10 ~ + 85 | 1 |
| AC-2030-2 | 30 | 50 | 54000 | 200 | 2,0 | - 10 ~ + 85 | 1 |
| AC-2030-3 | 30 | 50 | 54000 | 700 | 1,0 | - 10 ~ + 85 | 1 |
| AC-2050-1 | 50 | 60 | 66000 | 60 | 3,5 | - 10 ~ + 85 | 1 |
| AC-2050-2 | 50 | 60 | 66000 | 400 | 2,0 | - 10 ~ + 85 | 1 |
| AC-2050-3 | 50 | 60 | 66000 | 1200 | 1,0 | - 10 ~ + 85 | 1 |
| ACD-2030-1 | 30 | 45 | 54000 | 40 | 3,5 | - 10 ~ + 85 | 1 |
| ACD-2030-2 | 30 | 45 | 54000 | 300 | 2,0 | - 10 ~ + 85 | 1 |
| ACD-2030-3 | 30 | 45 | 54000 | 900 | 1,0 | - 10 ~ + 85 | 1 |
| ACD-2035-1 | 35 | 52 | 62000 | 40 | 3,5 | - 10 ~ + 85 | 1 |
| ACD-2035-2 | 35 | 52 | 62000 | 200 | 2,0 | - 10 ~ + 85 | 1 |
| ACD-2035-3 | 35 | 52 | 62000 | 650 | 1,0 | - 10 ~ + 85 | 1 |
| AC-2525-1 | 25 | 80 | 60000 | 200 | 4,0 | - 10 ~ + 85 | 1 |
| AC-2525-2 | 25 | 80 | 60000 | 800 | 2,5 | - 10 ~ + 85 | 1 |
| AC-2525-3 | 5 | 80 | 60000 | 1500 | 1,0 | - 10 ~ + 85 | 1 |
| AC-2540-1 | 40 | 120 | 84000 | 300 | 4,0 | - 10 ~ + 85 | 1 |
| AC-2540-2 | 40 | 120 | 84000 | 1200 | 2,5 | - 10 ~ + 85 | 1 |
| AC-2540-3 | 40 | 120 | 84000 | 2000 | 1,0 | - 10 ~ + 85 | 1 |
| AC-2550-1 | 50 | 98 | 98000 | 15 | 4,0 | - 10 ~ + 85 | 1 |
| AC-2550-2 | 50 | 98 | 98000 | 40 | 2,5 | - 10 ~ + 85 | 1 |
| AC-2550-3 | 50 | 98 | 98000 | 160 | 1,0 | - 10 ~ + 85 | 1 |
| AC-2580-1 | 80 | 150 | 127500 | 20 | 4,0 | - 10 ~ + 85 | 1 |
| AC-2580-2 | 80 | 150 | 127500 | 50 | 2,5 | - 10 ~ + 85 | 1 |
| AC-2580-3 | 80 | 150 | 127500 | 200 | 1,0 | - 10 ~ + 85 | 1 |
| AC-3660-1 | 60 | 250 | 125000 | 400 | 4,0 | - 10 ~ + 85 | 1 |
| AC-3660-2 | 60 | 250 | 125000 | 1500 | 2,5 | - 10 ~ + 85 | 1 |
| AC-3660-3 | 60 | 250 | 125000 | 2400 | 1,0 | - 10 ~ + 85 | 1 |

DECELERATORI SERIE AD - *SHOCK ABSORBERS - AD SERIES*



COME ORDINARE - *HOW TO ORDER*

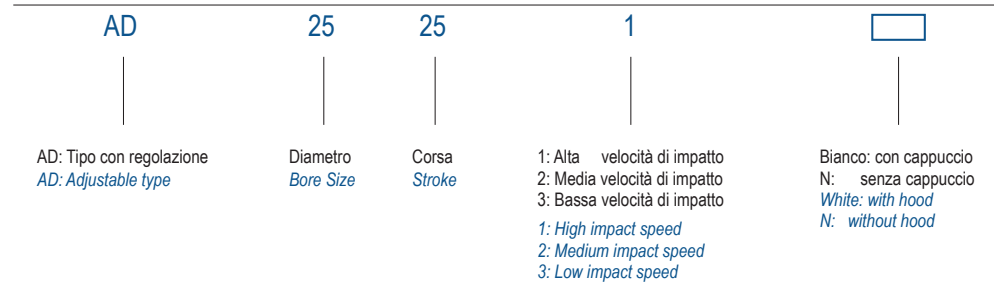

Esempio: AD 2525-1N - Tipo con regolazione - Alta velocità di impatto - Senza cappuccio
Example: AD 2525-1N - Adjustable type - High impact speed - Without hood

| COD | CORSA STROKE | ENERGIA MAX ASSORBIBILE PER CICLO MAX. ASSORBABLE ENERGY PER CYCLE (NM) | ENERGIA MAX ASSORBIBILE PER ORA MAX. ASSORBABLE ENERGY PER HOUR (NM/hr) | PESO MAX MAX WEIGHT (Kg) | MAX VELOCITÀ DI IMPATTO MAX IMPACT SPEED (m/s) | TEMPERATURA DI ESERCIZIO WORKING TEMPERATURE (°C) | 🛒 |
|----------|-----------------|--|--|--------------------------------|--|---|---|
| AD-1410 | 10 | 20 | 24000 | 80 | 3,2 | - 10 °C ~ + 85°C | 1 |
| AD-1415 | 15 | 22 | 26400 | 120 | 3,2 | - 10 °C ~ + 85°C | 1 |
| AD-2016 | 16 | 25 | 32000 | 200 | 3,6 | - 10 °C ~ + 85°C | 1 |
| AD-2050 | 25 | 39 | 39000 | 312 | 3,6 | - 10 °C ~ + 85°C | 1 |
| AD-2525 | 25 | 85 | 51000 | 400 | 3,6 | - 10 °C ~ + 85°C | 1 |
| AD-2530 | 30 | 95 | 57000 | 480 | 3,6 | - 10 °C ~ + 85°C | 1 |
| AD-2540 | 40 | 100 | 84000 | 700 | 3,6 | - 10 °C ~ + 85°C | 1 |
| AD-2550 | 50 | 98 | 98000 | 720 | 4,2 | - 10 °C ~ + 85°C | 1 |
| AD-2580 | 80 | 150 | 275000 | 800 | 4,2 | - 10 °C ~ + 85°C | 1 |
| AD-3625 | 25 | 150 | 90000 | 1400 | 3,2 | - 10 °C ~ + 85°C | 1 |
| AD-3650 | 50 | 300 | 108000 | 1400 | 3,2 | - 10 °C ~ + 85°C | 1 |
| AD-4225 | 25 | 260 | 130000 | 3000 | 3,6 | - 10 °C ~ + 85°C | 1 |
| AD-4250 | 50 | 500 | 155000 | 4000 | 4,8 | - 10 °C ~ + 85°C | 1 |
| AD-4275 | 75 | 750 | 187500 | 6000 | 4,8 | - 10 °C ~ + 85°C | 1 |
| AD-64050 | 50 | 12000 | 1560000 | 12727 | 1,6 | - 10 °C ~ + 85°C | 1 |
| AD-64100 | 100 | 24000 | 1920000 | 18181 | 1,6 | - 10 °C ~ + 85°C | 1 |
| AD-64150 | 150 | 36000 | 2520000 | 23636 | 1,6 | - 10 °C ~ + 85°C | 1 |

PRINCIPIO DI FUNZIONAMENTO - *PRINCIPLE OF OPERATION*

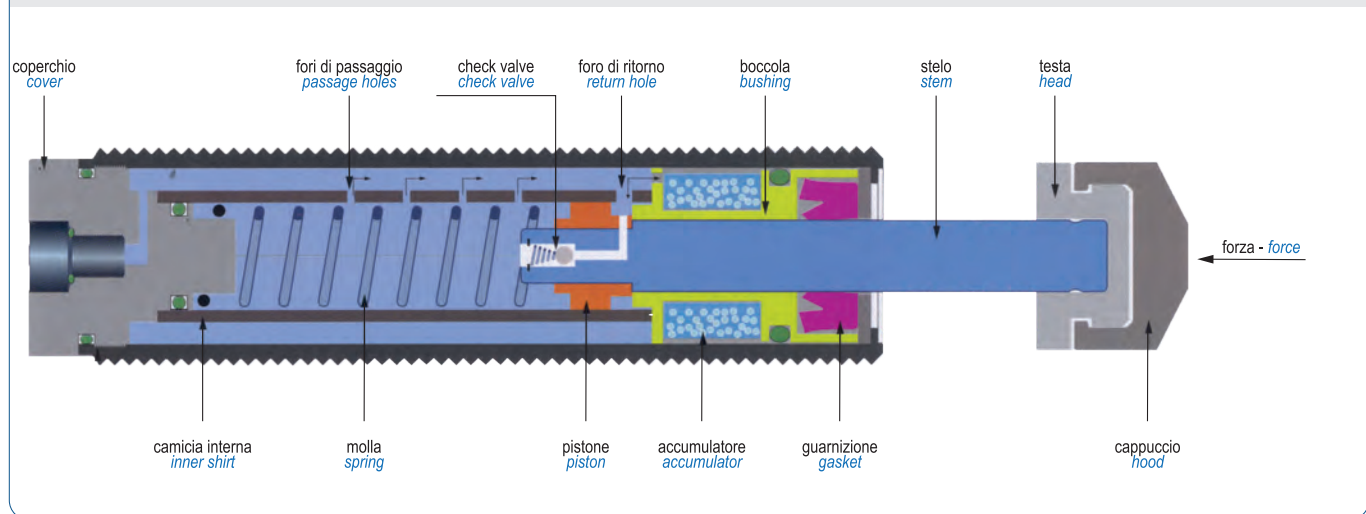



| | | |
|---|---------------------------|--------------------------------|
| 1 | DISTRIBUTORE GREZZO | <i>DISTRIBUTOR (RAW)</i> |
| 2 | CILINDRO DI AZIONAMENTO | <i>DRIVE CYLINDER</i> |
| 3 | FILTRO REGOLAZIONE | <i>AIR FILTER</i> |
| 4 | DISTRUBUTORE (ASSEMBLATO) | <i>DISTRIBUTOR (ASSEMBLED)</i> |
| 5 | PANNELLO DI COMANDO | <i>CONTROL PANEL</i> |

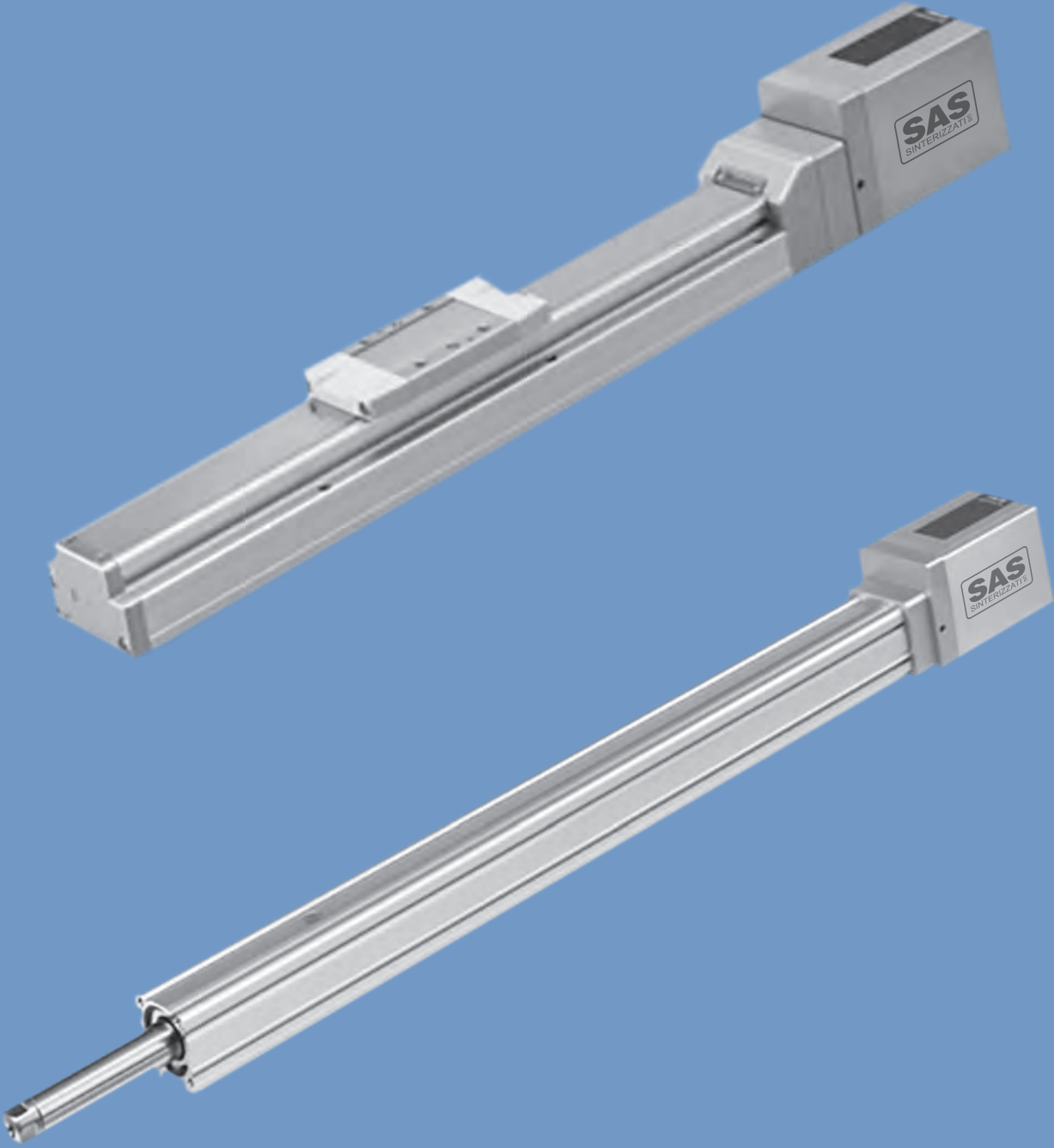

ELECTRIC ACTUATORS

ATTUATORI ELETTRICI SENZA STELO - *ELECTRIC ACTUATORS WITHOUT STEM*

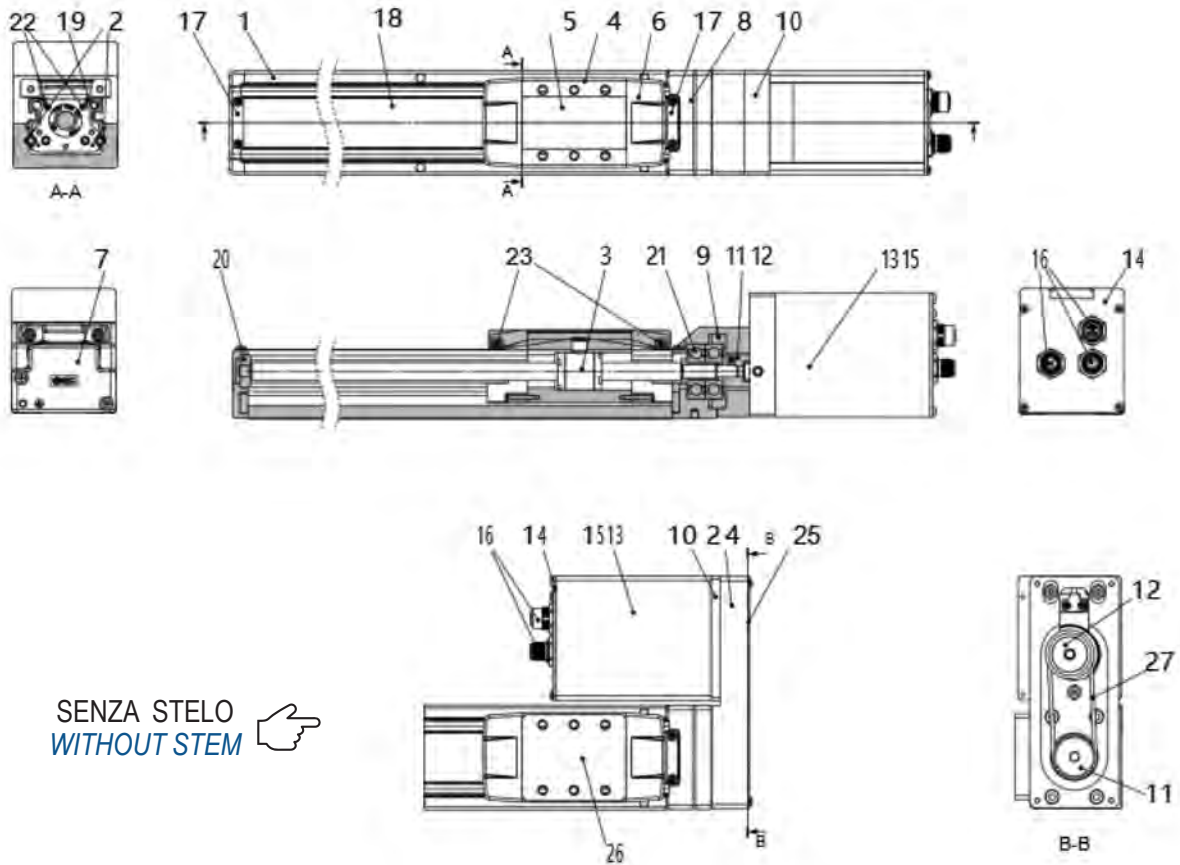

| N. | SPECIFICHE | N. | SPECIFICATIONS |
|----|--|----|--|
| 1 | Corpo lega di alluminio trattamento ossidante | 1 | Body Aluminum alloy oxidizing treatment |
| 2 | Rotaia | 2 | Rail |
| 3 | Componente a vite a sfera | 3 | Ball screw component |
| 4 | Piattaforma lega di alluminio trattamento ossidante | 4 | Oxidizing treatment aluminum alloy platform |
| 5 | Coperchio lega di alluminio trattamento ossidante | 5 | Oxidizing treated aluminum alloy cover |
| 6 | Piastra di tenuta in gomma resina sintetica | 6 | Synthetic resin rubber sealing plate |
| 7 | Parte A - Alluminio pressofuso verniciato | 7 | Part A - Painted die-cast aluminium |
| 8 | Parte B - Alluminio pressofuso verniciato | 8 | Part B - Painted die-cast aluminium |
| 9 | Supporto cuscinetto lega di alluminio verniciato | 9 | Painted aluminum alloy bearing support |
| 10 | Collegamento motore lega di alluminio | 10 | Aluminum alloy motor connection |
| 11 | Puleggia a cinghia del mandrino lega di alluminio | 11 | Aluminum alloy spindle belt pulley |
| 12 | Puleggia a cinghia del motore lega di alluminio | 12 | Aluminum alloy motor belt pulley |
| 13 | Coperchio del motore lega di alluminio + trattamento ossidante | 13 | Aluminum alloy engine cover + oxidizing treatment |
| 14 | Coperchio finale lega di alluminio + trattamento ossidante | 14 | End cover aluminum alloy + oxidizing treatment |
| 15 | Motore | 15 | Motor |
| 16 | Estremità | 16 | End |
| 17 | Piastra di pressione in acciaio inossidabile | 17 | Stainless steel pressure plate |
| 18 | Gomma di tenuta antipolvere in acciaio inossidabile | 18 | Stainless steel dust seal rubber |
| 19 | Anello magnetico | 19 | magnetic ring |
| 20 | Cuscinetto (in caso di corsa superiore a 201) | 20 | Bearing (in case of stroke greater than 201) |
| 21 | Cuscinetto | 21 | Bearing |
| 22 | Magnete | 22 | Magnet |
| 23 | Asse ruota in acciaio inossidabile (se necessaria) | 23 | Stainless steel wheel axle (if required) |
| 24 | Pannello pieghevole in lega di alluminio - Rivestimento | 24 | Aluminum Alloy Folding Panel - Cladding |
| 25 | Copertura in lega di alluminio + trattamento anodico | 25 | Aluminum alloy cover + anodizing treatment |
| 26 | Separatore del tavolo scorrevole in lega di alluminio+ trattamento anodico | 26 | Aluminum alloy sliding table separator + anodizing treatment |
| 27 | Nastro a gradini | 27 | Step tape |

ATTUATORI ELETTRICI CON STELO - *ELECTRIC ACTUATORS WITH STEM*

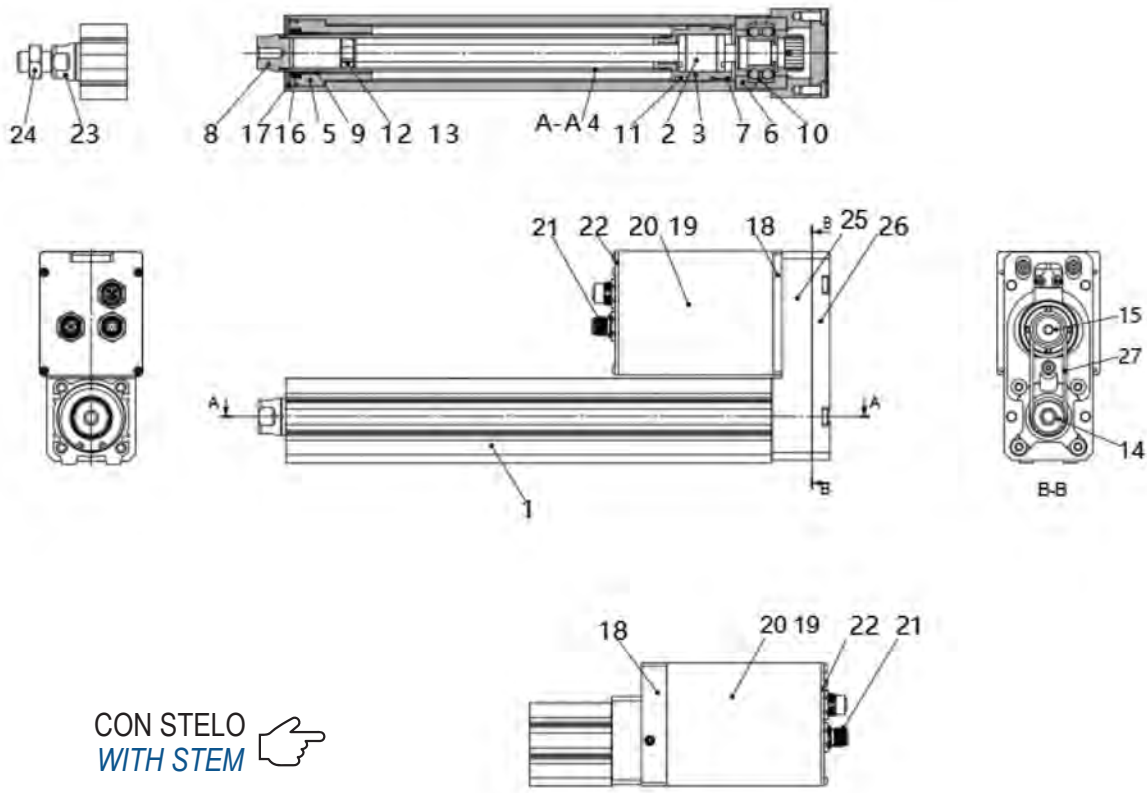

CON STELO
WITH STEM 

| N. | SPECIFICHE | N. | SPECIFICATIONS |
|----|---|----|---|
| 1 | Corpo principale | 1 | Main body |
| 2 | Assemblaggio della vite a sfera | 2 | Aluminum alloy |
| 3 | Lega di alluminio | 3 | Oxidation treatment |
| 4 | Acciaio inossidabile - Rivestimento in cromo duro | 4 | Stainless Steel - Hard chrome coating |
| 5 | Coperchio del cilindro laterale in lega di alluminio | 5 | Aluminum alloy side cylinder cover |
| 6 | Supporto per cuscinetti in lega di alluminio | 6 | Aluminum alloy bearing support |
| 7 | Blocco anti-ritorno in resina sintetica | 7 | Synthetic resin anti-return block |
| 8 | Presca (filettatura interna) in acciaio ad alta velocità - Rivestimento in nichel | 8 | High speed steel socket (Internal thread) - Nickel coating |
| 9 | Giunto in lega (cuscinetto) | 9 | Alloy joint (bearing) |
| 10 | Cuscinetto | 10 | Bearing |
| 11 | Magnete | 11 | Magnet |
| 12 | Anello di supporto anti-vibrazione in acciaio inossidabile | 12 | Stainless steel anti-vibration support ring |
| 13 | Anello di vibrazione in resina sintetica (in caso di corsa superiore a 101) | 13 | Synthetic resin vibration ring (in case of stroke greater than 101) |
| 14 | Puleggia della vite in lega di alluminio | 14 | Aluminum alloy screw pulley |
| 15 | Puleggia del motore in lega di alluminio | 15 | Aluminum alloy motor pulley |
| 16 | O-ring (NBR) | 16 | O-ring (NBR) |
| 17 | Anello elastico (acciaio per molle) | 17 | Circlip (spring steel) |
| 18 | Collegamento del motore - Lega di alluminio (Trattamento di ossidazione) | 18 | Engine Connection - Aluminum Alloy (Oxidation Treatment) |
| 19 | Motore | 19 | Motor |
| 20 | Copertura del motore in lega di alluminio | 20 | Aluminum alloy engine cover |
| 21 | Testa di lavoro | 21 | Working head |
| 22 | Coperchio in lega di alluminio | 22 | Aluminum alloy cover |
| 23 | Presca (filettatura esterna) in acciaio ad alta velocità | 23 | Socket (external thread) made of high speed steel |
| 24 | Dado esagonale | 24 | Hex nut |
| 25 | Blocco a ritorno | 25 | Return block |
| 26 | Pannello pieghevole | 26 | Folding panel |
| 27 | Cinghia sincrona in alluminio pressofuso | 27 | Die-cast aluminum synchronous belt |

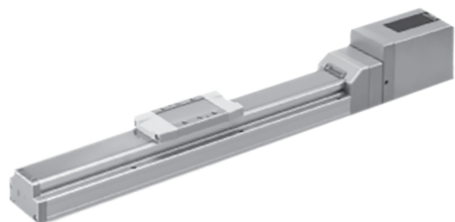

ATTUATORI ELETTRICI SENZA STELO
ELECTRIC ACTUATORS WITHOUT STEM



ATTUATORI ELETTRICI CON STELO
ELECTRIC ACTUATORS WITH STEM

Attuatori elettrici

La meccanica del cilindro elettrico è basata su collaudate viti a ricircolo di sfere in una molteplicità di svariate combinazioni di diametri e passi. La vite a sfere trasforma la coppia di serraggio del motore ad elevato rendimento in un movimento lineare, l'asta del pistone fissata alla chiocciola dell'azionamento a vite, viene rientrata ed estratta.

La vite è fissata direttamente allo stelo del cilindro o al carrello quando l'attuatore è senza stelo.

Sia la chiocciola dell'azionamento a vite che l'asta del pistone sono integrate nel supporto e assicurate contro la rotazione. Selezionabili a scelta, interruttori di fine corsa prevengono un danneggiamento del cilindro durante il funzionamento. Per l'impiego di sistemi di encoder incrementali (per un preciso posizionamento del carico) è disponibile un micro interruttore di riferimento. Grazie alla lubrificazione a grasso i cilindri elettrici richiedono un impegno ridotto per la manutenzione, con lunghi intervalli.

Electric actuators

The mechanics of the electric cylinder are based on proven ball screws in a multiplicity of various combinations of diameters and steps. The ball screw transforms the tightening torque of the high-performance motor into a linear movement, the piston rod attached to the screw drive snail, is indented and pulled out.

The screw is fixed directly to the cylinder rod or to the carriage when the actuator is rodless.

Both the screw drive snail and the piston rod are integrated into the support and secured against rotation. Selectable by choice, end-of-stroke switches prevent damage to the cylinder during operation. For the use of incremental encoder systems (for precise load positioning) a micro reference switch is available. Thanks to grease lubrication, electric cylinders require a reduced effort for maintenance, with long intervals.

ATTUATORI ELETTRICI SENZA STELO - *ELECTRIC ACTUATORS WITHOUT STEM*



ALESAGGIO - *BORE SIZE*

| mm | 16 | 20 | 25 | 32 | 40 | 50 |
|------------|----|----|----|----|----|----|
| | ☒ | ☒ | ☒ | ☒ | ☒ | ☒ |
| 1 - 100 | 1 | 1 | 1 | 1 | 1 | 1 |
| 101 - 200 | 1 | 1 | 1 | 1 | 1 | 1 |
| 201 - 300 | 1 | 1 | 1 | 1 | 1 | 1 |
| 301 - 400 | 1 | 1 | 1 | 1 | 1 | 1 |
| 401 - 500 | 1 | 1 | 1 | 1 | 1 | 1 |
| 501 - 600 | 1 | 1 | 1 | 1 | 1 | 1 |
| 601 - 700 | 1 | 1 | 1 | 1 | 1 | 1 |
| 701 - 800 | 1 | 1 | 1 | 1 | 1 | 1 |
| 801 - 900 | 1 | 1 | 1 | 1 | 1 | 1 |
| 901 - 1000 | 1 | 1 | 1 | 1 | 1 | 1 |

ATTUATORI ELETTRICI CON STELO - *ELECTRIC ACTUATORS WITH STEM*



ALESAGGIO - *BORE SIZE*

| mm | 16 | 20 | 25 | 32 | 40 | 50 |
|------------|----|----|----|----|----|----|
| | ☒ | ☒ | ☒ | ☒ | ☒ | ☒ |
| 1 - 100 | 1 | 1 | 1 | 1 | 1 | 1 |
| 101 - 200 | 1 | 1 | 1 | 1 | 1 | 1 |
| 201 - 300 | 1 | 1 | 1 | 1 | 1 | 1 |
| 301 - 400 | 1 | 1 | 1 | 1 | 1 | 1 |
| 401 - 500 | 1 | 1 | 1 | 1 | 1 | 1 |
| 501 - 600 | 1 | 1 | 1 | 1 | 1 | 1 |
| 601 - 700 | 1 | 1 | 1 | 1 | 1 | 1 |
| 701 - 800 | 1 | 1 | 1 | 1 | 1 | 1 |
| 801 - 900 | 1 | 1 | 1 | 1 | 1 | 1 |
| 901 - 1000 | 1 | 1 | 1 | 1 | 1 | 1 |



HANDLING

CILINDRI SPECIALI - *HANDLING*

| | | | | | |
|---|-----|-----|--|---|-----|
|  | CDS | 255 |  | RG | 257 |
|  | CAR | 255 |  | CPR-C CPR-L | 257 |
|  | CS | 255 |  | SENSORI MAGNETICI PER CILINDRI C2B - M - C MAGNETIC SENSORS FOR CYLINDERS C2B - M - C | 258 |
|  | CSR | 255 |  | STAFFA TIPO F2 PER SENSORI MAGNETICI SMAP BRACKET TYPE F2 FOR MAGNETIC SENSORS SMAP | 258 |
|  | CSL | 255 |  | STAFFA TIPO S2 PER SENSORI MAGNETICI SMAP BRACKET TYPE S2 FOR MAGNETIC SENSORS SMAP | 258 |
|  | PP | 256 |  | SENSORI MAGNETICI PER MON- TAGGIO IN CAVA PER CILINDRI SERIE C2B - MAGNETIC SEN- SORS FOR MOUNTING GROOVE TYPE - MOUNTING EXAMPLE | 258 |
|  | PY | 256 |  | SENSORI MAGNETICI PER CILINDRI PP - PY - PT - AG MAGNETIC SENSORS FOR CYLINDERS PP - PY - PT - AG | 259 |
|  | PT | 256 |  | SENSORI MAGNETICI PER CILINDRI CDS - CAR - TR MAGNETIC SENSORS FOR CYLINDERS CDS - CAR - TR | 259 |
|  | PF3 | 256 |  | SENSORI MAGNETICI PER CILINDRI CS - CSR - CSL MAGNETIC SENSORS FOR CYLINDERS CS - CSR - CSL | 259 |
|  | AG | 257 |  | SENSORI MAGNETICI PER CILINDRI SS-P0 - SS-P1 - SS-P2 MAGNETIC SENSORS FOR CYLINDERS SS-P0 - SS-P1 SS-P2 | 259 |
|  | TR | 257 |  | SENSORI MAGNETICI PER CILINDRI CSS-M2 - CSS-M3 MAGNETIC SENSORS FOR CYLINDERS CSS-M2 - CSS-M3 | 259 |

CDS - CILINDRI DOPPIO STELO - TWIN ROD CYLINDERS



| COD | CORSA 20 STROKE 20 | CORSA 40 STROKE 40 | CORSA 60 STROKE 60 | CORSA 75 STROKE 75 | CORSA 100 STROKE 100 |
|--------|-----------------------|-----------------------|-----------------------|-----------------------|-------------------------|
| CDS-10 | 1 | 1 | 1 | 1 | 1 |
| CDS-16 | 1 | 1 | 1 | 1 | 1 |
| CDS-20 | 1 | 1 | 1 | 1 | 1 |
| CDS-25 | 1 | 1 | 1 | 1 | 1 |
| CDS-32 | 1 | 1 | 1 | 1 | 1 |

CARATTERISTICHE
 CILINDRI SERIE CDS DOPPIO EFFETTO
 CODIFICA: CDS - Ø C
 CDS = SIGLA MODELLO
 Ø = DIAMETRO CILINDRO
 C = CORSA
 SENSORE TIPO HX - 07
 VERSIONI SPECIALI A RICHIESTA

FEATURES
 DOUBLE ACTING CYLINDERS CDS SERIES
 ENCODING: CDS - Ø C
 CDS = MODEL
 Ø = BORE SIZE
 C = STROKE
 MAGNETIC SENSOR HX - 07 TYPE
 SPECIAL VERSION ON REQUEST

CAR - CILINDRI ANTI ROTAZIONE - ANTI ROTATION CYLINDERS



STANDARD CON BRONZINE
 CON CUSCINETTI A SFERA: +30%
 STANDARD WITH BUSHINGS
 WITH BALL BEARINGS: + 30%

| COD | CORSA 10 STROKE 10 | CORSA 20 STROKE 20 | CORSA 30 STROKE 30 | CORSA 40 STROKE 40 | CORSA 50 STROKE 50 |
|--------|-----------------------|-----------------------|-----------------------|-----------------------|-----------------------|
| CAR-12 | 1 | 1 | 1 | 1 | 1 |
| CAR-16 | 1 | 1 | 1 | 1 | 1 |
| CAR-20 | 1 | 1 | 1 | 1 | 1 |
| CAR-25 | 1 | 1 | 1 | 1 | 1 |
| CAR-32 | 1 | 1 | 1 | 1 | 1 |

CARATTERISTICHE
 CILINDRI SERIE CAR DOPPIO EFFETTO
 CODIFICA: CAR - Ø C
 CAR = SIGLA MODELLO
 Ø = DIAMETRO CILINDRO
 C = CORSA
 SENSORE TIPO HX - 07
 VERSIONI SPECIALI A RICHIESTA

FEATURES
 DOUBLE ACTING CYLINDERS CAR SERIES
 ENCODING: CAR - Ø C
 CAR = MODEL
 Ø = BORE SIZE
 C = STROKE
 MAGNETIC SENSOR HX - 07 TYPE
 SPECIAL VERSION ON REQUEST

CS / CSR / CSL - CILINDRI STOPPER - STOPPER CYLINDERS



| COD | CORSA 10 STROKE 10 | CORSA 20 STROKE 20 | CORSA 30 STROKE 30 |
|-------|-----------------------|-----------------------|-----------------------|
| CS-12 | 1 | 1 | 1 |
| CS-16 | 1 | 1 | 1 |
| CS-20 | 1 | 1 | 1 |
| CS-25 | 1 | 1 | 1 |
| CS-32 | 1 | 1 | 1 |
| CS-40 | 1 | 1 | 1 |

CARATTERISTICHE
 CILINDRI SERIE CS DOPPIO EFFETTO
 CODIFICA: CS - Ø C
 CS = SIGLA MODELLO
 Ø = DIAMETRO CILINDRO
 C = CORSA
 VERSIONI SPECIALI A RICHIESTA
 SENSORE TIPO HX - 11

FEATURES
 DOUBLE ACTING CYLINDERS CS SERIES
 ENCODING: CS - Ø C
 CS = MODEL
 Ø = BORE SIZE
 C = STROKE
 MAGNETIC SENSOR HX - 11 TYPE
 SPECIAL VERSION ON REQUEST



| COD | CORSA 10 STROKE 10 | CORSA 20 STROKE 20 | CORSA 30 STROKE 30 |
|--------|-----------------------|-----------------------|-----------------------|
| CSR-12 | 1 | 1 | 1 |
| CSR-16 | 1 | 1 | 1 |
| CSR-20 | 1 | 1 | 1 |
| CSR-25 | 1 | 1 | 1 |

CARATTERISTICHE
 CILINDRI SERIE CSR DOPPIO EFFETTO
 CODIFICA: CSR - Ø C
 CSR = SIGLA MODELLO
 Ø = DIAMETRO CILINDRO
 C = CORSA
 VERSIONI SPECIALI A RICHIESTA
 SENSORE TIPO HX - 11

FEATURES
 DOUBLE ACTING CYLINDERS CSR SERIES
 ENCODING: CSR - Ø C
 CSR = MODEL
 Ø = BORE SIZE
 C = STROKE
 MAGNETIC SENSOR HX - 11 TYPE
 SPECIAL VERSION ON REQUEST



| COD | CORSA 10 STROKE 10 | CORSA 20 STROKE 20 | CORSA 30 STROKE 30 |
|--------|-----------------------|-----------------------|-----------------------|
| CSL-20 | 1 € | 1 | 1 |
| CSL-25 | 1 | 1 | 1 |
| CSL-32 | 1 | 1 | 1 |
| CSL-40 | 1 | 1 | 1 |
| CSL-50 | 1 | 1 | 1 |

CARATTERISTICHE
 CILINDRI SERIE CSL DOPPIO EFFETTO
 CODIFICA: CSL - Ø C
 CSL = SIGLA MODELLO
 Ø = DIAMETRO CILINDRO
 C = CORSA
 VERSIONI SPECIALI A RICHIESTA
 SENSORE TIPO HX - 11

FEATURES
 DOUBLE ACTING CYLINDERS CSL SERIES
 ENCODING: CSL - Ø C
 CSL = MODEL
 Ø = BORE SIZE
 C = STROKE
 MAGNETIC SENSOR HX - 11 TYPE
 SPECIAL VERSION ON REQUEST

CILINDRI SPECIALI - *HANDLING*

PP - PINZA PARALLELA - *PNEUMATIC PARALLEL GRIPPER*



| COD | DIAMETRO Ø DIAMETER Ø | 🛒 |
|-------|--------------------------|---|
| PP-10 | 10 | 1 |
| PP-16 | 16 | 1 |
| PP-20 | 20 | 1 |
| PP-25 | 25 | 1 |
| PP-32 | 32 | 1 |
| PP-40 | 40 | 1 |

CARATTERISTICHE
 CILINDRI SERIE PP DOPPIO EFFETTO
 CODIFICA: PP - Ø
 PP = SIGLA MODELLO
 Ø = DIAMETRO CILINDRO
 C = CORSA
 SENSORE TIPO HX - 01
 VERSIONI SPECIALI A RICHIESTA
FEATURES
 DOUBLE ACTING CYLINDERS PP SERIES
 ENCODING: PP - Ø
 PP = MODEL
 Ø = BORE SIZE
 MAGNETIC SENSOR HX - 01 TYPE
 SPECIAL VERSION ON REQUEST

PY - PINZA AD Y 90° - *PNEUMATIC 90° ANGULAR GRIPPER*



| COD | DIAMETRO Ø DIAMETER Ø | 🛒 |
|-------|--------------------------|---|
| PY-10 | 10 | 1 |
| PY-16 | 16 | 1 |
| PY-20 | 20 | 1 |
| PY-25 | 25 | 1 |
| PY-32 | 32 | 1 |
| PY-40 | 40 | 1 |

CARATTERISTICHE
 CILINDRI SERIE PY DOPPIO EFFETTO
 CODIFICA: PY - Ø
 PY = SIGLA MODELLO
 Ø = DIAMETRO CILINDRO
 C = CORSA
 SENSORE TIPO HX - 01
 VERSIONI SPECIALI A RICHIESTA
FEATURES
 DOUBLE ACTING CYLINDERS PY SERIES
 ENCODING: PY - Ø
 PY = MODEL
 Ø = BORE SIZE
 MAGNETIC SENSOR HX - 01 TYPE
 SPECIAL VERSION ON REQUEST

PT - PINZA AD Y 180° - *PNEUMATIC 180° ANGULAR GRIPPER*



| COD | DIAMETRO Ø DIAMETER Ø | 🛒 |
|---------|--------------------------|---|
| PT - 10 | 10 | 1 |
| PT - 16 | 16 | 1 |
| PT - 20 | 20 | 1 |
| PT - 25 | 25 | 1 |
| PT - 32 | 32 | 1 |
| PT - 40 | 40 | 1 |

CARATTERISTICHE
 CILINDRI SERIE PT DOPPIO EFFETTO
 CODIFICA: PT - Ø
 PT = SIGLA MODELLO
 Ø = DIAMETRO
 SENSORE TIPO HX - 01
 VERSIONI SPECIALI A RICHIESTA
FEATURES
 DOUBLE ACTING CYLINDERS PT SERIES
 ENCODING: PT - Ø
 PT = MODEL
 Ø = BORE SIZE
 C = STROKE
 MAGNETIC SENSOR HX - 01 TYPE
 SPECIAL VERSION ON REQUEST

PF3 - PINZA FINGER - *FINGER PNEUMATIC GRIPPER*



| COD | DIAMETRO Ø DIAMETER Ø | 🛒 |
|----------|--------------------------|---|
| PF3 - 10 | 10 | 1 |
| PF3 - 16 | 16 | 1 |
| PF3 - 20 | 20 | 1 |
| PF3 - 25 | 25 | 1 |
| PF3 - 32 | 32 | 1 |
| PF3 - 40 | 40 | 1 |

CARATTERISTICHE
 CILINDRI SERIE PF3 DOPPIO EFFETTO
 CODIFICA: PF3 - Ø
 PF3 = SIGLA MODELLO
 Ø = DIAMETRO CILINDRO
 STANDARD: 3 FINGER
 SENSORE TIPO HX - 01
 VERSIONI SPECIALI A RICHIESTA
FEATURES
 DOUBLE ACTING CYLINDERS PF3 SERIES
 ENCODING: PF3 - Ø
 PF3 = MODEL
 Ø = BORE SIZE
 STANDARD: 3 FINGERS
 MAGNETIC SENSOR HX - 01 TYPE
 SPECIAL VERSION ON REQUEST

AG - AIR GRIPPER - *PNEUMATIC AIR GRIPPER*



| COD | CORSA STROKE | 🛒 |
|---------|-----------------|---|
| AG - 10 | 20 | 1 |
| AG - 16 | 30 | 1 |
| AG - 20 | 40 | 1 |
| AG - 25 | 50 | 1 |
| AG - 32 | 70 | 1 |
| AG - 40 | 100 | 1 |

CARATTERISTICHE
 CILINDRI SERIE AG DOPPIO EFFETTO
 CODIFICA: AG - Ø C
 AG = SIGLA MODELLO
 Ø = DIAMETRO CILINDRO
 C = CORSA
 SENSORE TIPO HX - 01
 VERSIONI SPECIALI A RICHIESTA

FEATURES
 DOUBLE ACTING CYLINDERS AG SERIES
 ENCODING: AG - Ø
 AG = MODEL
 Ø = BORE SIZE
 C = STROKE
 MAGNETIC SENSOR HX - 01 TYPE
 SPECIAL VERSION ON REQUEST

TR - TAVOLA ROTANTE - *PNEUMATIC ROTARY CYLINDER*



| COD | DIAMETRO Ø DIAMETER Ø | 🛒 |
|---------|--------------------------|---|
| TR - 10 | 10 | 1 |
| TR - 20 | 20 | 1 |
| TR - 30 | 30 | 1 |
| TR - 50 | 50 | 1 |

CARATTERISTICHE
 CILINDRI SERIE TR DOPPIO EFFETTO
 CODIFICA: TR - Ø
 TR = SIGLA MODELLO
 Ø = DIAMETRO CILINDRO
 STANDARD: CON AMMORTIZZO INTERNO
 SENSORE TIPO HX - 01
 VERSIONI SPECIALI A RICHIESTA

FEATURES
 DOUBLE ACTING CYLINDERS TR SERIES
 ENCODING: TR - Ø
 TR = MODEL
 Ø = BORE SIZE
 MAGNETIC SENSOR HX - 01 TYPE
 SPECIAL VERSION ON REQUEST

RG - ROTARY GRIPPER - *PNEUMATIC ROTARY GRIPPER*

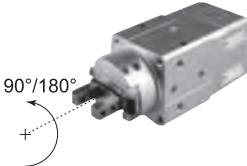

| COD | DIAMETRO Ø DIAMETER Ø | 🛒 |
|-------------|--------------------------|---|
| RG - 10/90 | 10/90° | 1 |
| RG - 10/180 | 10/180° | 1 |
| RG - 16/90 | 16/90° | 1 |
| RG - 16/180 | 16/180° | 1 |
| RG - 20/90 | 20/90° | 1 |
| RG - 20/180 | 20/180° | 1 |
| RG - 25/90 | 25/90° | 1 |
| RG - 25/180 | 25/180° | 1 |

CARATTERISTICHE
 CILINDRI SERIE RG DOPPIO EFFETTO
 CODIFICA: RG - Ø R°
 RG = SIGLA MODELLO
 Ø = DIAMETRO CILINDRO
 R° = ANGOLO DI ROTAZIONE
 VERSIONI SPECIALI A RICHIESTA

FEATURES
 DOUBLE ACTING CYLINDERS RG SERIES
 ENCODING: RG - Ø
 RG = MODEL
 Ø = BORE SIZE
 R° = ROTATION ANGLE
 SPECIAL VERSION ON REQUEST

CPR-C / CPR-L - CILINDRO PRESSORE - *PNEUMATIC CLAMPING CYLINDER*

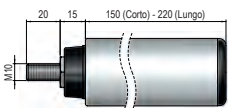

20 15 150 (Corto) - 220 (Lungo)

M10

C = TIPO CORTO
 L = SHORT TYPE
 C = TIPO CORTO
 L = LONG TYPE



Ammortizzo frontale in NBR in dotazione
 Front cushioning included (NBR)

| COD | TIPO CORTO - SHORT TYPE | | |
|------------|-------------------------|-----------------------|-------------------------|
| | CORSA 50 STROKE 50 | CORSA 75 STROKE 75 | CORSA 115 STROKE 115 |
| CPR - C 25 | 1 | 1 | 1 |
| CPR - C 35 | 1 | 1 | 1 |
| CPR - C 40 | 1 | 1 | 1 |
| CPR - C 50 | 1 | 1 | 1 |

| COD | TIPO LUNGO - LONG TYPE | | |
|------------|------------------------|-----------------------|-------------------------|
| | CORSA 50 STROKE 50 | CORSA 75 STROKE 75 | CORSA 115 STROKE 115 |
| CPR - L 25 | 1 | 1 | 1 |
| CPR - L 35 | 1 | 1 | 1 |
| CPR - L 40 | 1 | 1 | 1 |
| CPR - L 50 | 1 | 1 | 1 |

CARATTERISTICHE
 CILINDRI SERIE CPR SEMPLICE EFFETTO
 CODIFICA:
 CORTO: CPR-C Ø
 LUNGO: CPR-L Ø
 CPR = SIGLA MODELLO
 C = TIPO CORTO
 L = TIPO LUNGO
 Ø = DIAMETRO CILINDRO
 VERSIONI SPECIALI A RICHIESTA

FEATURES
 DOUBLE ACTING CYLINDERS CPR SERIES
 ENCODING:
 SHORT TYPE: CPR-C - Ø
 LONG TYPE: CPR-L - Ø
 CPR = MODEL
 C = SHORT
 L = LONG
 Ø = BORE SIZE
 SPECIAL VERSION ON REQUEST

SENSORI MAGNETICI - *MAGNETIC SENSORS*

SENSORI MAGNETICI PER CILINDRI C2B - M - C
MAGNETIC SENSORS FOR CYLINDERS C2B - M - C

| COD | TENSIONE VOLT | CIRCUITO CIRCUITO | LED LED | CONNESSIONE CONNECTION | SERIE CILINDRI CYLINDER SERIES | MONTAGGIO MOUNTING | |
|------------|-------------------|--|------------|-----------------------------|-----------------------------------|---|---|
| SMAP - 2CL | 3 + 30 V (AC-DC) | REED 2 CAVI <i>REED 2 CABLE</i> | SÌ YES | CAVO CABLE | C 2B - M - C | | 1 |
| SMAP - 3DL | 24 V (AC-DC) | REED 3 CAVI <i>REED 3 CABLE</i> | SÌ YES | CAVO CABLE | C 2B - M - C | | 1 |
| SMAP - 3NL | 6 + 30 V (DC) | HE 3 CAVI PNP <i>HE 3 CABLE PNP</i> | SÌ YES | CAVO CABLE | C 2B - M - C | | 1 |
| SMAP - 3ML | 6 + 30 V (DC) | HE 3 CAVI NPN <i>HE 3 CABLE NPN</i> | SÌ YES | CAVO CABLE | C 2B - M - C | CON STAFFA C2B: DIRETTO IN CAVA | 1 |
| SMAP - 2CC | 3 + 230 V (AC-DC) | REED 2 CAVI <i>REED 2 CABLE</i> | SÌ YES | CONN. M8 <i>CONN. M8</i> | C 2B - M - C | WITH BRACKET C2B: DIRECT IN THE SLOT | 1 |
| SMAP - 3DC | 24 V (AC-DC) | REED 3 CAVI <i>REED 3 CABLE</i> | SÌ YES | CONN. M8 <i>CONN. M8</i> | C 2B - M - C | | 1 |
| SMAP - 3NC | 6 + 30 V (DC) | HE 3 CAVI PNP <i>HE 3 CABLE PNP</i> | SÌ YES | CONN. M8 <i>CONN. M8</i> | C 2B - M - C | | 1 |
| SMAP - 3MC | 6 + 30 V (DC) | HE 3 CAVI NPN <i>HE 3 CABLE NPN</i> | SÌ YES | CONN. M8 <i>CONN. M8</i> | C 2B - M - C | | 1 |



STAFFA TIPO F2 PER SENSORI MAGNETICI SMAP
BRACKET TYPE F2 FOR MAGNETIC SENSORS SMAP

| COD | Ø CILINDRO Ø CYLINDER | TIPO CILINDRO CYLINDER | SENSORE SENSOR | ESEMPIO DI MONTAGGIO MOUNTING EXAMPLE | |
|---------|--------------------------|---------------------------|-------------------|--|---|
| F2 - 8 | 8 | M | | | 1 |
| F2 - 10 | 10 | M | | | 1 |
| F2 - 12 | 12 | M | | | 1 |
| F2 - 16 | 16 | M | | | 1 |
| F2 - 20 | 20 | M | | | 1 |
| F2 - 25 | 25 | M | | | 1 |





STAFFA TIPO S2 PER SENSORI MAGNETICI SMAP
BRACKET TYPE S2 FOR MAGNETIC SENSORS SMAP



| COD | Ø CILINDRO Ø CYLINDER | TIPO CILINDRO CYLINDER | SENSORE SENSOR | ESEMPIO DI MONTAGGIO MOUNTING EXAMPLE | |
|----------|--------------------------|---------------------------|-------------------|--|---|
| S2 - 32 | 32 | C | | | 1 |
| S2 - 32 | 40 | C | | | 1 |
| S2 - 50 | 50 | C | | | 1 |
| S2 - 63 | 63 | C | | | 1 |
| S2 - 63 | 80 | C | | | 1 |
| S2 - 100 | 100 | C | | | 1 |
| S2 - 100 | 125 | C | | | 1 |



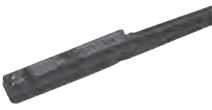

SENSORI MAGNETICI PER MONTAGGIO IN CAVA PER CILINDRI SERIE C2B
MAGNETIC SENSORS FOR MOUNTING GROOVE TYPE - MOUNTING EXAMPLE



| SENSORE SENSOR | TIPO CAVA SLOT TYPE | ESEMPIO DI MONTAGGIO MOUNTING EXAMPLE | |
|-------------------|------------------------|--|---|
| | | | 1 |

| SENSORI MAGNETICI PER CILINDRI PP - PY - PT - AG <i>MAGNETIC SENSORS FOR CYLINDERS PP - PY - PT - AG</i> | | | | |
|--|-----------|--------------------------------------|---|---|
|  Scanalatura rettangolare <i>Groove rectangular</i> | COD | Ø CILINDRO <i>BORE SIZE</i> | CARATTERISTICHE <i>FEATURES</i> |  |
| | HX - 01 D | SERIE COMPLETA <i>FULL SERIES</i> | 2 CAVETTI TIPO ELETTRONICO <i>2 WIRE ELECTRONIC TYPE</i> | 1 |
| | HX - 01 N | SERIE COMPLETA <i>FULL SERIES</i> | 3 CAVETTI TIPO ELETTRONICO NPN <i>3 WIRE ELECTRONIC NPN TYPE</i> | 1 |
| | HX - 01 P | SERIE COMPLETA <i>FULL SERIES</i> | 3 CAVETTI TIPO ELETTRONICO PNP <i>3 WIRE ELECTRONIC PNP TYPE</i> | 1 |
| | HX - 01 R | SERIE COMPLETA <i>FULL SERIES</i> | 2 CAVETTI INTERRUOTTORE REED <i>2 WIRE REED SWITCH TYPE</i> | 1 |

| SENSORI MAGNETICI PER CILINDRI CDS - CAR - TR <i>MAGNETIC SENSORS FOR CYLINDERS CDS - CAR - TR</i> | | | | |
|---|-----------|--------------------------------------|---|---|
|  Scanalatura tonda <i>Groove round</i> | COD | Ø CILINDRO <i>BORE SIZE</i> | CARATTERISTICHE <i>FEATURES</i> |  |
| | HX - 07 D | SERIE COMPLETA <i>FULL SERIES</i> | 2 CAVETTI TIPO ELETTRONICO <i>2 WIRE ELECTRONIC TYPE</i> | 1 |
| | HX - 07 N | SERIE COMPLETA <i>FULL SERIES</i> | 3 CAVETTI TIPO ELETTRONICO NPN <i>3 WIRE ELECTRONIC NPN TYPE</i> | 1 |
| | HX - 07 P | SERIE COMPLETA <i>FULL SERIES</i> | 3 CAVETTI TIPO ELETTRONICO PNP <i>3 WIRE ELECTRONIC PNP TYPE</i> | 1 |
| | HX - 07 R | SERIE COMPLETA <i>FULL SERIES</i> | 2 CAVETTI INTERRUOTTORE REED <i>2 WIRE REED SWITCH TYPE</i> | 1 |

| SENSORI MAGNETICI PER CILINDRI CS - CSR - CSL <i>MAGNETIC SENSORS FOR CYLINDERS CS - CSR - CSL</i> | | | | |
|---|-----------|--------------------------------------|---|---|
|  Scanalatura allungata <i>Groove elongated</i> | COD | Ø CILINDRO <i>BORE SIZE</i> | CARATTERISTICHE <i>FEATURES</i> |  |
| | HX - 11 D | SERIE COMPLETA <i>FULL SERIES</i> | 2 CAVETTI TIPO ELETTRONICO <i>2 WIRE ELECTRONIC TYPE</i> | 1 |
| | HX - 11 N | SERIE COMPLETA <i>FULL SERIES</i> | 3 CAVETTI TIPO ELETTRONICO NPN <i>3 WIRE ELECTRONIC NPN TYPE</i> | 1 |
| | HX - 11 P | SERIE COMPLETA <i>FULL SERIES</i> | 3 CAVETTI TIPO ELETTRONICO PNP <i>3 WIRE ELECTRONIC PNP TYPE</i> | 1 |
| | HX - 11 R | SERIE COMPLETA <i>FULL SERIES</i> | 2 CAVETTI INTERRUOTTORE REED <i>2 WIRE REED SWITCH TYPE</i> | 1 |

| SENSORI MAGNETICI PER CILINDRI SS-P0 - SS-P1 - SS-P2 <i>MAGNETIC SENSORS FOR CYLINDERS SS-P0 - SS-P1 - SS-P2</i> | | | | |
|---|-----------|---|---|---|
|  | COD | LOGICA DI COMMUTAZIONE <i>SWITCHING LOGIC</i> | CARATTERISTICHE <i>FEATURES</i> |  |
| | AL - 30 R | SPTS - NORMALMENTE APERTO <i>SPST - NORMALLY OPEN</i> | INTERRUPTORE A LAMELLA <i>REED SWITCH</i> | 1 |
| | AL - 30 N | USCITA STATO SOLIDO - NORMALMENTE APERTO <i>SOLID STATE OUTPUT NORMALLY OPEN</i> | NPN COMMUTAZIONE CORRENTE <i>NPN SWITCHING LOGIC</i> | 1 |
| | AL - 30 P | USCITA STATO SOLIDO - NORMALMENTE APERTO <i>SOLID STATE OUTPUT NORMALLY OPEN</i> | PNP COMMUTAZIONE CORRENTE <i>PNP SWITCHING LOGIC</i> | 1 |

| SENSORI MAGNETICI PER CILINDRI CSS-M2 - CSS-M3 <i>MAGNETIC SENSORS FOR CYLINDERS CSS-M2 - CSS-M3</i> | | | | |
|---|-----------|--------------------------------------|---|---|
|  | COD | Ø CILINDRO <i>BORE SIZE</i> | CARATTERISTICHE <i>FEATURES</i> |  |
| | HX - 31 D | SERIE COMPLETA <i>FULL SERIES</i> | 2 CAVETTI TIPO ELETTRONICO <i>2 WIRE ELECTRONIC TYPE</i> | 1 |
| | HX - 31 N | SERIE COMPLETA <i>FULL SERIES</i> | 3 CAVETTI TIPO ELETTRONICO NPN <i>3 WIRE ELECTRONIC NPN TYPE</i> | 1 |
| | HX - 31 P | SERIE COMPLETA <i>FULL SERIES</i> | 3 CAVETTI TIPO ELETTRONICO PNP <i>3 WIRE ELECTRONIC PNP TYPE</i> | 1 |
| | HX - 31 R | SERIE COMPLETA <i>FULL SERIES</i> | 2 CAVETTI INTERRUOTTORE REED <i>2 WIRE REED SWITCH TYPE</i> | 1 |

CILINDRI SPECIALI - *HANDLING*

CDS - CILINDRI DOPPIO STELO - *DOUBLE ROD CYLINDERS*



CAR - CILINDRI ANTI ROTAZIONE - *ANTI-ROTATION CYLINDERS*

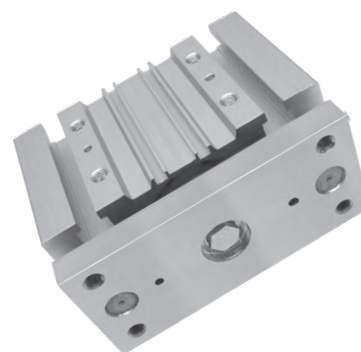

CS - CILINDRI STOPPER - *STOPPER CYLINDERS*

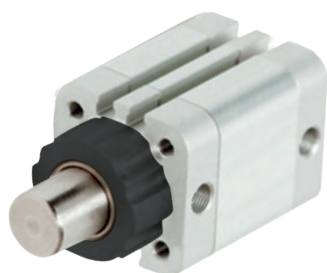

CSR - CILINDRI STOPPER - *STOPPER CYLINDERS*



CSL - CILINDRI STOPPER - *STOPPER CYLINDERS*



PP - PINZA PARALLELA - *PARALLEL GRIPPER*



PY - PINZAAD Y 90° - *90° Y GRIPPER*



PT - PINZAAD Y 180° - *180° Y GRIPPER*

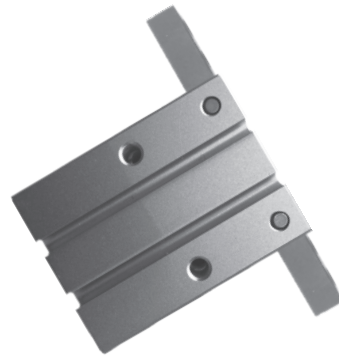

PF3 - PINZA FINGER - *FINGER CALIPER*

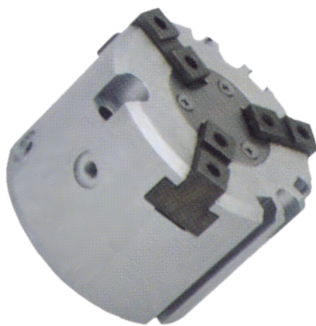

AG - AIR GRIPPER - *AIR GRIPPER*



TR - TAVOLA ROTANTE - *ROTATING TABLE*

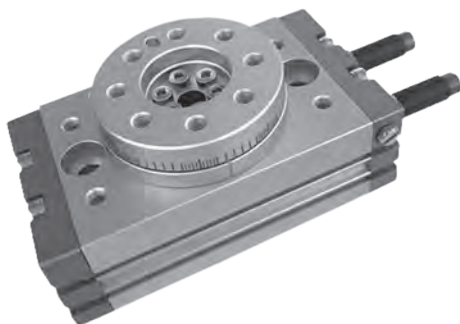



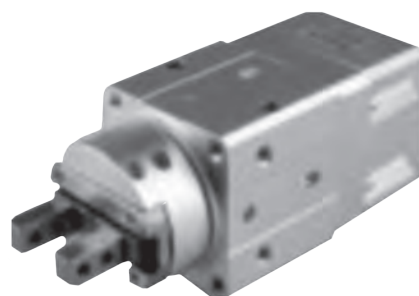







RG - ROTARY GRIPPER - *ROTARY GRIPPER*





CYLINDER'S MOUNTING PARTS

FISSAGGI - CYLINDER MOUNTING PARTS

| | | | | | |
|---|------|-----|--|---|-----|
|  | FCE | 266 |  | CM | 267 |
|  | FCEX | 266 |  | CF | 267 |
|  | TSF | 266 |  | CCO | 267 |
|  | TSM | 266 |  | PB ISO 6431 ACCIAIO ISO 6431 STAINLESS STEEL | 267 |
|  | TSFX | 266 |  | FL ISO 6431 ACCIAIO ISO 6431 STAINLESS STEEL | 267 |
|  | TSMX | 266 |  | CC ISO 6432 ACCIAIO ISO 6432 STAINLESS STEEL | 267 |
|  | TDS | 266 |  | PB ISO 6432 ACCIAIO ISO 6432 STAINLESS STEEL | 267 |
|  | SG | 266 |  | FL ISO 6432 ACCIAIO ISO 6432 STAINLESS STEEL | 267 |
|  | CMSS | 267 |  | CMSSX | 268 |

| | | | | | |
|---|---------|-----|---|--|-----|
|  | CMX | 268 |  | PCE | 269 |
|  | CFX | 268 |  | ANE | 269 |
|  | CCOX | 268 |  | PCT | 269 |
|  | PBX | 268 |  | COPI | 269 |
|  | FLX | 268 |  | CLIPSAX | 269 |
|  | CCX | 268 |  | PCEX | 269 |
|  | PBX | 268 |  | SEEGERSASX | 269 |
|  | FLX | 268 |  | CUFFIE IN NEOPRENE NEOPRENE PROTECTIONS | 270 |
|  | CLIP | 269 |  | DISTANZIALI IN ACCIAIO STEEL SPACERS | 270 |
|  | CLIPSAS | 269 | | | |

FISSAGGI: FORCELLE E TESTE A SNODO - CYLINDER'S MOUNTING PARTS: FORKS AND ROD ENDS

FCE



| COD | | 🛒 |
|--------|------------|----|
| FCE 3 | M3 x 0,50 | 10 |
| FCE 4 | M4 x 0,70 | 10 |
| FCE 5 | M5 x 0,80 | 10 |
| FCE 6 | M6 x 1,00 | 10 |
| FCE 8 | M8 x 1,25 | 10 |
| FCE 10 | M10 x 1,25 | 10 |
| FCE 12 | M12 x 1,25 | 10 |
| FCE 14 | M14 x 2,00 | 5 |
| FCE 16 | M16 x 1,50 | 5 |
| FCE 20 | M20 x 1,50 | 5 |
| FCE 24 | M24 x 2,00 | 1 |
| FCE 27 | M27 x 2,00 | 1 |
| FCE 36 | M36 x 2,00 | 1 |

Acciaio zincato
Galvanized steel

A richiesta modello Cnomo - *On request Cnomo Model*

FCEX



| COD | | 🛒 |
|---------|------------|----|
| FCEX 3 | M3 x 0,50 | 10 |
| FCEX 4 | M4 x 0,70 | 10 |
| FCEX 5 | M5 x 0,80 | 10 |
| FCEX 6 | M6 x 1,00 | 10 |
| FCEX 8 | M8 x 1,25 | 10 |
| FCEX 10 | M10 x 1,25 | 10 |
| FCEX 12 | M12 x 1,25 | 10 |
| FCEX 14 | M14 x 2,00 | 5 |
| FCEX 16 | M16 x 1,50 | 5 |
| FCEX 20 | M20 x 1,50 | 5 |
| FCEX 24 | M24 x 2,00 | 1 |
| FCEX 27 | M27 x 2,00 | 1 |
| FCEX 36 | M36 x 2,00 | 1 |

AISI 316 L ↑

AISI 303 ↓

TSF



| COD | | 🛒 |
|--------|------------|----|
| TSF 3 | M3 x 0,50 | 10 |
| TSF 5 | M4 x 0,70 | 10 |
| TSF 6 | M6 x 1,00 | 10 |
| TSF 8 | M8 x 1,25 | 10 |
| TSF 10 | M10 x 1,25 | 10 |
| TSF 12 | M12 x 1,25 | 10 |
| TSF 14 | M14 x 2,00 | 5 |
| TSF 16 | M16 x 1,50 | 5 |
| TSF 20 | M20 x 1,50 | 5 |
| TSF 27 | M27 x 2,00 | 1 |
| TSF 36 | M36 x 2,00 | 1 |

Acciaio zincato + bronzo
Galvanized steel + sintered bronze

A RICHIESTA DISPONIBILE ANCHE DI IMPORTAZIONE
IMPORT TYPE AVAILABLE ON REQUEST

TSM



| COD | | 🛒 |
|--------|------------|----|
| TSM 6 | M6 x 1,00 | 10 |
| TSM 8 | M8 x 1,25 | 10 |
| TSM 10 | M10 x 1,50 | 10 |
| TSM 12 | M12 x 1,75 | 10 |
| TSM 14 | M14 x 2,00 | 5 |
| TSM 16 | M16 x 2,00 | 5 |
| TSM 20 | M20 x 1,50 | 5 |

Acciaio zincato + bronzo
Galvanized steel + sintered bronze

A RICHIESTA DISPONIBILE ANCHE DI IMPORTAZIONE
IMPORT TYPE AVAILABLE ON REQUEST

TSFX



| COD | | 🛒 |
|---------|------------|----|
| TSFX 3 | M3 x 0,50 | 10 |
| TSFX 5 | M5 x 0,70 | 10 |
| TSFX 6 | M6 x 1,00 | 10 |
| TSFX 8 | M8 x 1,25 | 10 |
| TSFX 10 | M10 x 1,25 | 10 |
| TSFX 12 | M12 x 1,25 | 10 |
| TSFX 14 | M14 x 2,00 | 5 |
| TSFX 16 | M16 x 1,50 | 5 |
| TSFX 20 | M20 x 1,50 | 5 |

AISI 316 L

A RICHIESTA DISPONIBILE ANCHE DI IMPORTAZIONE
IMPORT TYPE AVAILABLE ON REQUEST

TSMX



| COD | | 🛒 |
|---------|------------|----|
| TSMX 5 | M5 x 0,80 | 10 |
| TSMX 6 | M6 x 1,00 | 10 |
| TSMX 8 | M8 x 1,25 | 10 |
| TSMX 10 | M10 x 1,50 | 10 |
| TSMX 12 | M12 x 1,25 | 10 |
| TSMX 14 | M14 x 2,00 | 5 |
| TSMX 16 | M16 x 2,00 | 5 |
| TSMX 20 | M20 x 1,50 | 5 |

AISI 316 L

A RICHIESTA DISPONIBILE ANCHE DI IMPORTAZIONE
IMPORT TYPE AVAILABLE ON REQUEST

TDS



| COD | | 🛒 |
|--------|------------|----|
| TDS 6 | M6 x 1,00 | 10 |
| TDS 8 | M8 x 1,25 | 10 |
| TDS 10 | M10 x 1,25 | 10 |
| TDS 12 | M12 x 1,25 | 10 |
| TDS 14 | M14 x 2,00 | 5 |
| TDS 16 | M16 x 1,50 | 5 |
| TDS 20 | M20 x 1,50 | 5 |
| TDS 27 | M27 x 2,00 | 1 |
| TDS 36 | M36 x 2,00 | 1 |

SG



| COD | | 🛒 |
|-------|------------|----|
| SG 5 | M5 x 0,80 | 10 |
| SG 6 | M6 x 1,00 | 10 |
| SG 8 | M8 x 1,25 | 10 |
| SG 10 | M10 x 1,50 | 10 |
| SG 12 | M12 x 1,75 | 10 |

Acciaio zincato
Galvanized steel

FISSAGGI IN ALLUMINIO E ACCIAIO - *ALUMINIUM AND STEEL FIXINGS*

ACCESSORI PER CILINDRI ISO 6431 IN ALLUMINIO - *ISO 6431 CYLINDERS ALUMINIUM ACCESSORIES*

CMSS



| COD | | 🛒 |
|----------|-------|---|
| CMSS 32 | Ø 32 | 1 |
| CMSS 40 | Ø 40 | 1 |
| CMSS 50 | Ø 50 | 1 |
| CMSS 63 | Ø 63 | 1 |
| CMSS 80 | Ø 80 | 1 |
| CMSS 100 | Ø 100 | 1 |
| CMSS 125 | Ø 125 | 1 |
| CMSS 160 | Ø 160 | 1 |
| CMSS 200 | Ø 200 | 1 |

Alluminio
Completa di viti
Aluminium
Supplied with screws

CM



| COD | | 🛒 |
|--------|-------|---|
| CM 32 | Ø 32 | 1 |
| CM 40 | Ø 40 | 1 |
| CM 50 | Ø 50 | 1 |
| CM 63 | Ø 63 | 1 |
| CM 80 | Ø 80 | 1 |
| CM 100 | Ø 100 | 1 |
| CM 125 | Ø 125 | 1 |
| CM 160 | Ø 160 | 1 |
| CM 200 | Ø 200 | 1 |

Alluminio
Completa di viti
Aluminium
Supplied with screws

CF



| COD | | 🛒 |
|--------|-------|---|
| CF 32 | Ø 32 | 1 |
| CF 40 | Ø 40 | 1 |
| CF 50 | Ø 50 | 1 |
| CF 63 | Ø 63 | 1 |
| CF 80 | Ø 80 | 1 |
| CF 100 | Ø 100 | 1 |
| CF 125 | Ø 125 | 1 |
| CF 160 | Ø 160 | 1 |
| CF 200 | Ø 200 | 1 |

Alluminio
Completa di perno e viti
Aluminium
Supplied with pin and screws

CCO



| COD | | 🛒 |
|---------|-------|---|
| CCO 32 | Ø 32 | 1 |
| CCO 40 | Ø 40 | 1 |
| CCO 50 | Ø 50 | 1 |
| CCO 63 | Ø 63 | 1 |
| CCO 80 | Ø 80 | 1 |
| CCO 100 | Ø 100 | 1 |
| CCO 125 | Ø 125 | 1 |
| CCO 160 | Ø 160 | 1 |
| CCO 200 | Ø 200 | 1 |

Alluminio
Completa di viti
Aluminium
Supplied with screws

ACCESSORI PER CILINDRI ISO 6431 IN ACCIAIO - *ISO 6431 CYLINDERS STEEL ACCESSORIES*

PB



| COD | | 🛒 |
|--------|-------|---|
| PB 32 | Ø 32 | 1 |
| PB 40 | Ø 40 | 1 |
| PB 50 | Ø 50 | 1 |
| PB 63 | Ø 63 | 1 |
| PB 80 | Ø 80 | 1 |
| PB 100 | Ø 100 | 1 |
| PB 125 | Ø 125 | 1 |
| PB 160 | Ø 160 | 1 |
| PB 200 | Ø 200 | 1 |

Acciaio nichelato
Completa di viti
Nickel plated steel
Supplied with screws

FL



| COD | | 🛒 |
|--------|-------|---|
| FL 32 | Ø 32 | 1 |
| FL 40 | Ø 40 | 1 |
| FL 50 | Ø 50 | 1 |
| FL 63 | Ø 63 | 1 |
| FL 80 | Ø 80 | 1 |
| FL 100 | Ø 100 | 1 |
| FL 125 | Ø 125 | 1 |
| FL 160 | Ø 160 | 1 |
| FL 200 | Ø 200 | 1 |

Acciaio nichelato
Completa di viti
Nickel plated steel
Supplied with screws

ACCESSORI PER CILINDRI ISO 6432 IN ACCIAIO - *ISO 6432 CYLINDERS STEEL ACCESSORIES*

CC



| COD | | 🛒 |
|----------|---------|---|
| CC 08/10 | Ø 8/10 | 1 |
| CC 12/16 | Ø 12/16 | 1 |
| CC 20/25 | Ø 20/25 | 1 |

Acciaio nichelato
Nickel plated steel

PB



| COD | | 🛒 |
|----------|---------|---|
| PB 08/10 | Ø 8/10 | 1 |
| PB 12/16 | Ø 12/16 | 1 |
| PB 20/25 | Ø 20/25 | 1 |

Acciaio nichelato
Nickel plated steel

FL



| COD | | 🛒 |
|----------|---------|---|
| FL 08/10 | Ø 8/10 | 1 |
| FL 12/16 | Ø 12/16 | 1 |
| FL 20/25 | Ø 20/25 | 1 |

Acciaio nichelato
Nickel plated steel

FISSAGGI IN ACCIAIO INOX AISI 316 L - AISI 316 L STAINLESS STEEL MOUNTING PARTS

ACCESSORI PER CILINDRI ISO 6431 INOX - ISO 6431 STAINLESS STEEL CYLINDERS ACCESSORIES

CMSSX



| COD | | 🛒 |
|-----------|-------|---|
| CMSSX 32 | Ø 32 | 1 |
| CMSS X 40 | Ø 40 | 1 |
| CMSSX 50 | Ø 50 | 1 |
| CMSSX 63 | Ø 63 | 1 |
| CMSSX 80 | Ø 80 | 1 |
| CMSSX 100 | Ø 100 | 1 |
| CMSSX 125 | Ø 125 | 1 |

AISI 316 L
Completa di viti
AISI 316 L
Supplied with screws

CMX



| COD | | 🛒 |
|---------|-------|---|
| CMX 32 | Ø 32 | 1 |
| CMX 40 | Ø 40 | 1 |
| CMX 50 | Ø 50 | 1 |
| CMX 63 | Ø 63 | 1 |
| CMX 80 | Ø 80 | 1 |
| CMX 100 | Ø 100 | 1 |
| CMX 125 | Ø 125 | 1 |

AISI 316 L
Completa di viti
AISI 316 L
Supplied with screws

CFX



| COD | | 🛒 |
|---------|-------|---|
| CFX 32 | Ø 32 | 1 |
| CFX 40 | Ø 40 | 1 |
| CFX 50 | Ø 50 | 1 |
| CFX 63 | Ø 63 | 1 |
| CFX 80 | Ø 80 | 1 |
| CXF 100 | Ø 100 | 1 |
| CFX 125 | Ø 125 | 1 |

AISI 316 L
Completa di perno
e di viti
AISI 316 L
*Supplied with pin
and screws*

CCOX



| COD | | 🛒 |
|----------|-------|---|
| CCOX 32 | Ø 32 | 1 |
| CCOX 40 | Ø 40 | 1 |
| CCOX 50 | Ø 50 | 1 |
| CCOX 63 | Ø 63 | 1 |
| CCOX 80 | Ø 80 | 1 |
| CCOX 100 | Ø 100 | 1 |
| CCOX 125 | Ø 125 | 1 |

AISI 316 L
Completa di viti
AISI 316 L
Supplied with screws

ACCESSORI PER CILINDRI ISO 6431 INOX - ISO 6431 STAINLESS STEEL CYLINDERS ACCESSORIES

PBX



| COD | | 🛒 |
|---------|-------|---|
| PBX 32 | Ø 32 | 1 |
| PBX 40 | Ø 40 | 1 |
| PBX 50 | Ø 50 | 1 |
| PBX 63 | Ø 63 | 1 |
| PBX 80 | Ø 80 | 1 |
| PBX 100 | Ø 100 | 1 |
| PBX 125 | Ø 125 | 1 |

AISI 316 L
Completa di viti
AISI 316 L
Supplied with screws

FLX



| COD | | 🛒 |
|---------|-------|---|
| FLX 32 | Ø 32 | 1 |
| FLX 40 | Ø 40 | 1 |
| FLX 50 | Ø 50 | 1 |
| FL X 63 | Ø 63 | 1 |
| FLX 80 | Ø 80 | 1 |
| FLX 100 | Ø 100 | 1 |
| FLX 125 | Ø 125 | 1 |

AISI 316 L
Completa di viti
AISI 316 L
Supplied with screws

ACCESSORI PER CILINDRI ISO 6432 INOX - ISO 6432 STAINLESS STEEL CYLINDERS ACCESSORIES

CCX



| COD | | 🛒 |
|-----------|---------|---|
| CCX 08/10 | Ø 8/10 | 1 |
| CCX 12/16 | Ø 12/16 | 1 |
| CCX 20/25 | Ø 20/25 | 1 |

AISI 316 L

PBX



| COD | | 🛒 |
|-----------|---------|---|
| PBX 08/10 | Ø 8/10 | 1 |
| PBX 12/16 | Ø 12/16 | 1 |
| PBX 20/25 | Ø 20/25 | 1 |

AISI 316 L

FLX



| COD | | 🛒 |
|-----------|---------|---|
| FLX 08/10 | Ø 8/10 | 1 |
| FLX 12/16 | Ø 12/16 | 1 |
| FLX 20/25 | Ø 20/25 | 1 |

AISI 316 L

CLIP



| COD | | | 🛒 |
|------|---------|----|---|
| C 4 | 4 x 8 | 10 | |
| C 5 | 5 x 10 | 10 | |
| C 6 | 6 x 12 | 10 | |
| C 8 | 8 x 16 | 10 | |
| C 10 | 10 x 20 | 10 | |
| C 12 | 12 x 24 | 10 | |
| C 14 | 14 x 28 | 5 | |
| C 16 | 16 x 32 | 5 | |
| C 20 | 20 x 40 | 5 | |

Acciaio zincato
Galvanized steel

CLIPSAS



| COD | | | 🛒 |
|------------|---------|----|---|
| CLIPSAS 3 | 3 x 6 | 10 | |
| CLIPSAS 4 | 4 x 8 | 10 | |
| CLIPSAS 5 | 5 x 10 | 10 | |
| CLIPSAS 6 | 6 x 12 | 10 | |
| CLIPSAS 8 | 8 x 16 | 10 | |
| CLIPSAS 10 | 10 x 20 | 10 | |
| CLIPSAS 12 | 12 x 24 | 10 | |
| CLIPSAS 14 | 14 x 28 | 5 | |
| CLIPSAS 16 | 16 x 32 | 5 | |
| CLIPSAS 20 | 20 x 40 | 5 | |

Acciaio zincato
Galvanized steel

PCE



| COD | | | 🛒 |
|--------|---------|----|---|
| PCE 4 | 4 x 13 | 10 | |
| PCE 6 | 6 x 17 | 10 | |
| PCE 8 | 8 x 21 | 10 | |
| PCE 10 | 10 x 25 | 10 | |
| PCE 12 | 12 x 30 | 10 | |
| PCE 14 | 14 x 35 | 5 | |
| PCE 16 | 16 x 39 | 5 | |
| PCE 20 | 20 x 48 | 5 | |
| PCE 24 | 25 x 60 | 1 | |
| PCE 27 | 30 x 65 | 1 | |
| PCE 36 | 35 x 84 | 1 | |

Acciaio zincato
Galvanized steel

ANE



| COD | | | 🛒 |
|--------|---------|----|---|
| ANE 3 | 3 x 10 | 25 | |
| ANE 4 | 4 x 13 | 25 | |
| ANE 5 | 5 x 14 | 25 | |
| ANE 6 | 6 x 17 | 25 | |
| ANE 8 | 8 x 21 | 25 | |
| ANE 10 | 10 x 25 | 25 | |
| ANE 12 | 12 x 30 | 25 | |
| ANE 14 | 14 x 35 | 10 | |
| ANE 16 | 16 x 39 | 10 | |
| ANE 20 | 20 x 48 | 10 | |
| ANE 24 | 25 x 60 | 2 | |
| ANE 27 | 30 x 65 | 2 | |
| ANE 36 | 35 x 84 | 2 | |

Acciaio
Steel

PCT



| COD | | | 🛒 |
|--------|---------|----|---|
| PCT 4 | 4 x 12 | 10 | |
| PCT 5 | 5 x 14 | 10 | |
| PCT 6 | 6 x 16 | 10 | |
| PCT 8 | 8 x 20 | 10 | |
| PCT 10 | 10 x 25 | 10 | |
| PCT 12 | 12 x 30 | 10 | |
| PCT 14 | 14 x 35 | 5 | |
| PCT 16 | 16 x 40 | 5 | |
| PCT 20 | 20 x 49 | 5 | |

Acciaio zincato
Galvanized steel

COPI



| COD | | | 🛒 |
|-----------|---------|----|---|
| COPI 0910 | 4 x 12 | 10 | |
| COPI 1310 | 5 x 14 | 10 | |
| COPI 1810 | 6 x 16 | 10 | |
| COPI 1815 | 8 x 20 | 10 | |
| COPI 2715 | 10 x 25 | 10 | |
| COPI 2720 | 12 x 30 | 10 | |
| COPI 3720 | 14 x 35 | 5 | |
| COPI 3725 | 16 x 40 | 5 | |
| COPI 3730 | 20 x 49 | 5 | |

Acciaio
Steel

CLIPSASX



| COD | | | 🛒 |
|-------------|---------|----|---|
| CLIPSASX 3 | 3 x 6 | 10 | |
| CLIPSASX 4 | 4 x 8 | 10 | |
| CLIPSASX 5 | 5 x 10 | 10 | |
| CLIPSASX 6 | 6 x 12 | 10 | |
| CLIPSASX 8 | 8 x 16 | 10 | |
| CLIPSASX 10 | 10 x 20 | 10 | |
| CLIPSASX 12 | 12 x 24 | 10 | |
| CLIPSASX 14 | 14 x 28 | 5 | |
| CLIPSASX 16 | 16 x 32 | 5 | |
| CLIPSASX 20 | 20 x 40 | 5 | |

AISI 303 + AISI 316 L

PCEX



| COD | | | 🛒 |
|---------|---------|----|---|
| PCEX 3 | 3 x 10 | 10 | |
| PCEX 4 | 4 x 13 | 10 | |
| PCEX 5 | 5 x 14 | 10 | |
| PCEX 6 | 6 x 17 | 10 | |
| PCEX 8 | 8 x 21 | 10 | |
| PCEX 10 | 10 x 25 | 10 | |
| PCEX 12 | 12 x 30 | 10 | |
| PCEX 14 | 14 x 35 | 5 | |
| PCEX 16 | 16 x 39 | 5 | |
| PCEX 20 | 20 x 48 | 5 | |
| PCEX 24 | 25 x 60 | 1 | |
| PCEX 27 | 30 x 65 | 1 | |
| PCEX 36 | 35 x 84 | 1 | |

AISI 316 L

SEEGERSASX



| COD | | | 🛒 | COD | | | 🛒 |
|---------------|---------|---|---|---------------|---------|---|---|
| SEEGERSASX 3 | 3 x 10 | 1 | | SEEGERSASX 14 | 14 x 35 | 1 | |
| SEEGERSASX 4 | 4 x 13 | 1 | | SEEGERSASX 16 | 16 x 39 | 1 | |
| SEEGERSASX 5 | 5 x 14 | 1 | | SEEGERSASX 20 | 20 x 48 | 1 | |
| SEEGERSASX 6 | 6 x 17 | 1 | | SEEGERSASX 25 | 25 x 60 | 1 | |
| SEEGERSASX 8 | 8 x 21 | 1 | | SEEGERSASX 30 | 30 x 65 | 1 | |
| SEEGERSASX 10 | 10 x 25 | 1 | | SEEGERSASX 35 | 35 x 85 | 1 | |
| SEEGERSASX 12 | 12 x 30 | 1 | | | | | |

AISI 303

PROTEZIONI IN GOMMA PER TESTE A SNODO - *ROD ENDS RUBBER PROTECTIONS*

 CUFFIE IN NEOPRENE - *NEOPRENE PROTECTIONS*

| COD | DIMENSIONE TESTA A SNODO <i>ROD ENDS SIZE</i> | 🛒 |
|---------|--|---|
| CTS - 6 | 6 | 5 |
| CTS - 8 | 8 | 5 |
| CTS -10 | 10 | 5 |
| CTS -12 | 12 | 5 |
| CTS -14 | 14 | 5 |
| CTS -16 | 16 | 5 |
| CTS -20 | 20 | 5 |

 DISTANZIALI IN ACCIAIO - *STEEL SPACERS*

AISI 316 L
 FORNITI IN COPPIA
AISI 316 L
 SUPPLIED IN PAIRS

| COD | DIMENSIONE TESTA A SNODO <i>ROD ENDS SIZE</i> | QUANTITÀ <i>QUANTITY</i> | 🛒 |
|---------|--|-----------------------------|---|
| DTS - 6 | 6 | 2 | 5 |
| DTS - 8 | 8 | 2 | 5 |
| DTS -10 | 10 | 2 | 5 |
| DTS -12 | 12 | 2 | 5 |
| DTS -14 | 14 | 2 | 5 |
| DTS -16 | 16 | 2 | 5 |
| DTS -20 | 20 | 2 | 5 |



FORNITE SOLO IN KIT (CUFFIA + DISTANZIALI) - MONTAGGIO: UTILIZZARE UNA PINZA PER ANELLI SEEGER
 SUPPLIED ONLY KIT (PROTECION+ SPACERS) - TO ASSEMBLY: USE A PLIERS FOR SEEGER RINGS





















TAURUS® è un marchio registrato SAS Sinterizzati
TAURUS® is a registered trademark of SAS Sinterizzati

Per maggiori chiarimenti e specifiche consultare il relativo Fascicolo Tecnico.
For further clarifications and specifications, consult the relevant Technical File.



AIR TREATMENT UNITS

| | | | | | |
|---|------------------------------|-----|--|-------------------------------|-----|
|  | FR+L TIPO "A" "A" TYPE | 276 |  | RPR | 276 |
|  | FR TIPO "A" "A" TYPE | 276 |  | AP | 276 |
|  | R TIPO "A" "A" TYPE | 276 |  | VB | 276 |
|  | F TIPO "A" "A" TYPE | 276 |  | FR+ L TIPO "D" "D" TYPE | 277 |
|  | L TIPO "A" "A" TYPE | 276 |  | FR TIPO "D" "D" TYPE | 277 |
|  | L-TYPE | 276 |  | R TIPO "D" "D" TYPE | 277 |
|  | T-TYPE | 276 |  | R TIPO "D" "D" TYPE | 277 |
|  | O-TYPE | 276 |  | L TIPO "D" "D" TYPE | 277 |
|  | Y-TYPE | 276 |  | SAC | 277 |

| | | | | | |
|---|-------------------|-----|---|-----------|-----|
|  | MF 40 | 277 |  | USFR-X-AP | 280 |
|  | MF 50 | 277 |  | USR-X-AP | 280 |
|  | FR-X-BP 1/4" | 278 |  | USF-X-AP | 280 |
|  | SSFR-L-X 600 AP | 279 |  | USL-X-AP | 280 |
|  | SSFR-X 500 AP | 279 |  | "A" TYPE | 280 |
|  | MINI SSR-X 200 AP | 279 |  | "B" TYPE | 280 |
|  | SSF-X 200 AP | 279 |  | "C" TYPE | 280 |
|  | MINI SSL-X 200 AP | 279 |  | "D" TYPE | 280 |
|  | USFR-L-X-AP | 280 | | | |

TRATTAMENTO ARIA TIPO "A" - AIR TREATMENT UNITS - "A" TYPE

FR+L



| COD | DIMENSIONI SIZES | 🛒 |
|------------|---------------------|---|
| AC 1010-M5 | M5 | 1 |
| AC 2010-01 | G 1/8" | 1 |
| AC 2010-02 | G 1/4" | 1 |
| AC 3010-02 | G 1/4" | 1 |
| AC 3010-03 | G 3/8" | 1 |
| AC 4010-03 | G 3/8" | 1 |
| AC 4010-04 | G 1/2" | 1 |
| AC 4010-06 | G 3/4" | 1 |
| AC 5010-06 | G 3/4" | 1 |
| AC 5010-10 | G1" | 1 |

FR



| COD | DIMENSIONI SIZES | 🛒 |
|------------|---------------------|---|
| AW 1000-M5 | M5 | 1 |
| AW 2000-01 | G 1/8" | 1 |
| AW 2000-02 | G 1/4" | 1 |
| AW 3000-02 | G 1/4" | 1 |
| AW 3000-03 | G 3/8" | 1 |
| AW 4000-03 | G 3/8" | 1 |
| AW 4000-04 | G 1/2" | 1 |
| AW 4000-06 | G 3/4" | 1 |
| AW 5000-06 | G 3/4" | 1 |
| AW 5000-10 | G1" | 1 |

AW 2000-02-M disponibile anche con tazza integrale in metallo
AW 2000-02-M also available with integral metal cup

R



| COD | DIMENSIONI SIZES | 🛒 |
|------------|---------------------|---|
| AR 1000-M5 | M5 | 1 |
| AR 2000-01 | G 1/8" | 1 |
| AR 2000-02 | G 1/4" | 1 |
| AR 3000-02 | G 1/4" | 1 |
| AR 3000-03 | G 3/8" | 1 |
| AR 4000-03 | G 3/8" | 1 |
| AR 4000-04 | G 1/2" | 1 |
| AR 4000-06 | G 3/4" | 1 |
| AR 5000-06 | G 3/4" | 1 |
| AR 5000-10 | G 1" | 1 |
| HAR 825-12 | G 1" 1/4 | 1 |
| HAR 825-14 | G 1" 1/2 | 1 |
| HAR 825-20 | G 2" | 1 |

F



| COD | DIMENSIONI SIZES | 🛒 |
|------------|---------------------|---|
| AF 1000-M5 | M5 | 1 |
| AF 2000-01 | G 1/8" | 1 |
| AF 2000-02 | G 1/4" | 1 |
| AF 3000-02 | G 1/4" | 1 |
| AF 3000-03 | G 3/8" | 1 |
| AF 4000-03 | G 3/8" | 1 |
| AF 4000-04 | G 1/2" | 1 |
| AF 4000-06 | G 3/4" | 1 |
| AF 5000-06 | G 3/4" | 1 |
| AF 5000-10 | G 1" | 1 |
| HAF 800-12 | G 1" 1/4 | 1 |
| HAF 800-14 | G 1" 1/2 | 1 |
| HAF 800-20 | G 2" | 1 |

L



| COD | DIMENSIONI SIZES | 🛒 |
|------------|---------------------|---|
| AL 1000-M5 | M5 | 1 |
| AL 2000-01 | G 1/8" | 1 |
| AL 2000-02 | G 1/4" | 1 |
| AL 3000-02 | G 1/4" | 1 |
| AL 3000-03 | G 3/8" | 1 |
| AL 4000-03 | G 3/8" | 1 |
| AL 4000-04 | G 1/2" | 1 |
| AL 4000-06 | G 3/4" | 1 |
| AL 5000-06 | G 3/4" | 1 |
| AL 5000-10 | G1" | 1 |

ACCESSORI - ACCESSORIES



L-TYPE T-TYPE
O-TYPE Y-TYPE

ARICHIESTA - ON REQUEST

RPR



**REGOLATORE DI PRECISIONE
PRECISION REGULATOR**

| COD | DIMENSIONI SIZES | 🛒 |
|----------|---------------------|---|
| RPR 2000 | G 1/4" | 1 |
| RPR 3000 | G 3/8" | 1 |
| RPR 4000 | G 1/2" | 1 |

AP



**AVVIATORE PROGRESSIVO
PROGRESSIVE STARTER**

| COD | DIMENSIONI SIZES | 🛒 |
|---------|---------------------|---|
| AP 2000 | G 1/4" | 1 |
| AP 3000 | G 3/8" | 1 |
| AP 4000 | G 1/2" | 1 |

VB



**VALVOLA DI BLOCCO
LOCK VALVE**

| COD | DIMENSIONI SIZES | 🛒 |
|---------|---------------------|---|
| VB 1000 | G 1/8" | 1 |
| VB 2000 | G 1/4" | 1 |
| VB 3000 | G 3/8" | 1 |
| VB 4000 | G 1/2" | 1 |

TRATTAMENTO ARIA TIPO "D" - AIR TREATMENT UNITS - "D" TYPE

FR+L



| COD | DIMENSIONI SIZES | 🛒 |
|-----------|---------------------|---|
| DC 101-M5 | M5 | 1 |
| DC 201-01 | G 1/8" | 1 |
| DC 201-02 | G 1/4" | 1 |
| DC 401-03 | G 3/8" | 1 |
| DC 401-04 | G 1/2" | 1 |
| DC 601-06 | G 3/4" | 1 |
| DC 601-08 | G 1" | 1 |

FR



| COD | DIMENSIONI SIZES | 🛒 |
|------------|---------------------|---|
| DFR 100-M5 | M5 | 1 |
| DFR 200-01 | G 1/8" | 1 |
| DFR 200-02 | G 1/4" | 1 |
| DFR 400-03 | G 3/8" | 1 |
| DFR 400-04 | G 1/2" | 1 |
| DFR 600-06 | G 3/4" | 1 |
| DFR 600-08 | G 1" | 1 |

R



| COD | DIMENSIONI SIZES | 🛒 |
|-----------|---------------------|---|
| DR 100-M5 | M5 | 1 |
| DR 200-01 | G 1/8" | 1 |
| DR 200-02 | G 1/4" | 1 |
| DR 400-03 | G 3/8" | 1 |
| DR 400-04 | G 1/2" | 1 |
| DR 600-06 | G 3/4" | 1 |
| DR 600-08 | G 1" | 1 |

F



| COD | DIMENSIONI SIZES | 🛒 |
|-----------|---------------------|---|
| DF 100-M5 | M5 | 1 |
| DF 200-01 | G 1/8" | 1 |
| DF 200-02 | G 1/4" | 1 |
| DF 400-03 | G 3/8" | 1 |
| DF 400-04 | G 1/2" | 1 |
| DF 600-06 | G 3/4" | 1 |
| DF 600-08 | G 1" | 1 |

L



| COD | DIMENSIONI SIZES | 🛒 |
|-----------|---------------------|---|
| DL 100-M5 | M5 | 1 |
| DL 200-01 | G 1/8" | 1 |
| DL 200-02 | G 1/4" | 1 |
| DL 400-03 | G 3/8" | 1 |
| DL 400-04 | G 1/2" | 1 |
| DL 600-06 | G 3/4" | 1 |
| DL 600-08 | G 1" | 1 |

SAC



| COD | 🛒 |
|-------|---|
| SAC 1 | 1 |

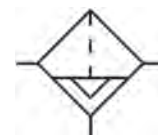

SCARICO AUTOMATICO CONDENZA
AUTOMATIC DRAIN

MF 40



| COD | 🛒 |
|------------|---|
| MF 40 1/8" | 1 |

MF 50



| COD | 🛒 |
|------------|---|
| MF 50 1/4" | 1 |

ACCESSORI E RICAMBI SU RICHIESTA:

- valvola luchettabile
- avviatore progressivo
- scarico rapido
- accessori di montaggio

ATTENZIONE: il manometro non è incluso

ACCESSORIES ON REQUEST:

- Lock valve
- Progressive starter
- Automatic drain
- Mounting brackets

ATTENTION: Pressure gauge is not included.

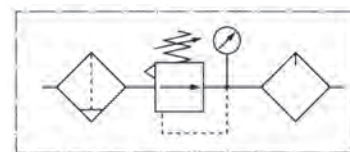

TRATTAMENTO ARIA TIPO "X" - AIR TREATMENT UNITS - "X" TYPE

AISI 316 L - BASSA PRESSIONE - AISI 316 L STAINLESS STEEL - LOW PRESSURE

FR-X-BP 1/4"



AISI 316 L
AISI 316 L

PRESSIONE INGRESSO - INLET PRESSURE (7 kg/cm²)

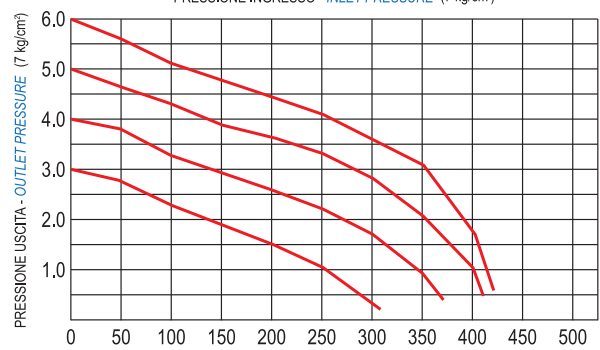

PRESSIONE USCITA - OUTLET PRESSURE (7 kg/cm²)

FLOW (LPM)

CARATTERISTICHE

| | |
|---------------------|------------------|
| FLUIDO | Aria |
| PRESSIONE | Max 15 Bar |
| PRESSIONE DI LAVORO | 0 - 8 Bar |
| GAMMA TEMPERATURA | - 20 ÷ 70°C |
| DIMENSIONE | PT 1/4 o NPT 1/4 |
| FEATURES | |
| FLUID | Air |
| MAX PRESSURE | Max 15 Bar |
| WORKING PRESSURE | 0 - 8 Bar |
| WORKING TEMPERATURE | - 20 ÷ 70°C |
| SIZE | PT 1/4 o NPT 1/4 |

| COD | MATERIALE MATERIAL | DIMENSIONI SIZES | |
|-----------|-----------------------|---------------------|-----|
| 2 FR-X-BP | AISI 316-L | 1/4" | 🛒 1 |

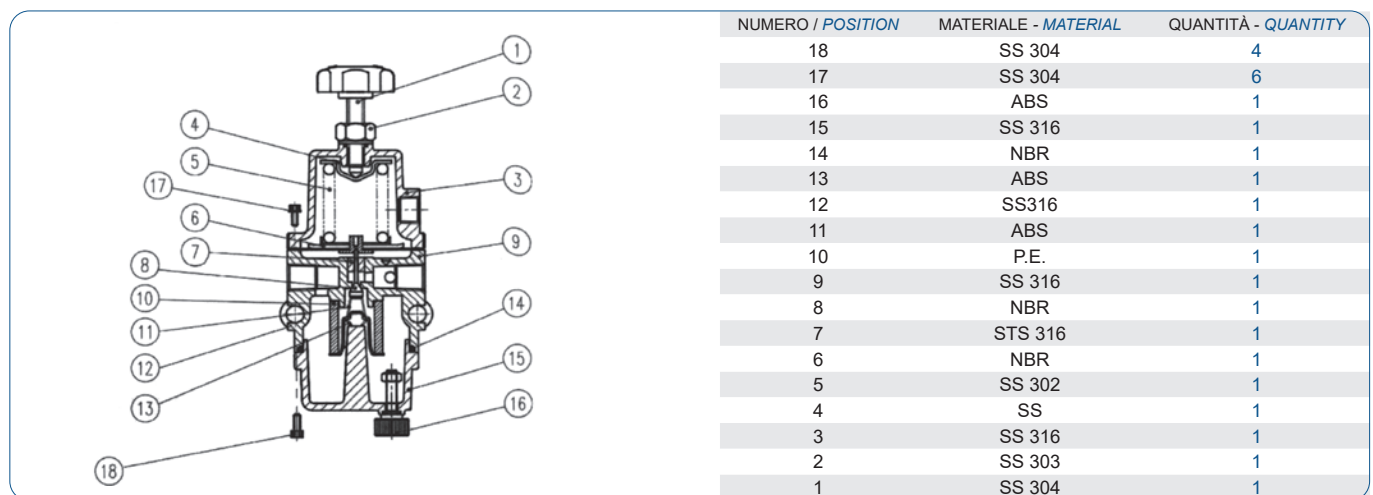
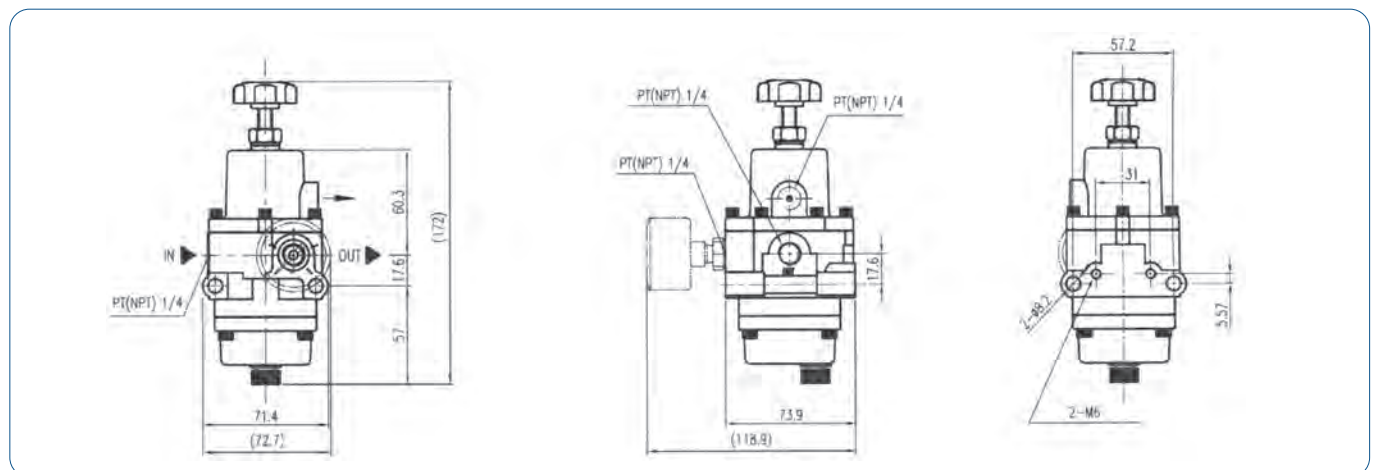

AISI 316 L - ALTA PRESSIONE - AISI 316 L STAINLESS STEEL - HIGH PRESSURE - MINI SERIES

SSFR-L-X 600 AP - FILTRO REGOLATORE + LUBRIFICATORE MINI - FILTER REGULATOR + MINI LUBRICATOR



AISI 316 L

| COD | DIMENSIONI SIZES | PORTATA MAX. MAX FLOW L/min | PRESSIONE DI ESERCIZIO WORKING PRESSURE | CARATTERISTICHE FEATURES | |
|-----------------|---------------------|-----------------------------------|--|--|---|
| SSFR-L-X 600 AP | 1/4" | 1850 | 0 ~ 20 kgf/cm ² | Filtro 40 μ - Scarico manuale Filter: 40 μ - Manual drain | 1 |

SSFR-X 500 AP - FILTRO REGOLATORE MINI - MINI FILTER REGULATOR



AISI 316 L

| COD | DIMENSIONI SIZES | PORTATA MAX. MAX FLOW L/min | PRESSIONE DI ESERCIZIO WORKING PRESSURE | CARATTERISTICHE FEATURES | |
|---------------|---------------------|-----------------------------------|--|--|---|
| SSFR-X 500 AP | 1/4" | 1850 | 0 ~ 20 kgf/cm ² | Filtro 40 μ - Scarico manuale Filter: 40 μ - Manual drain | 1 |

MINI SSR-X 200 AP - REGOLATORE - MINI REGULATOR



AISI 316 L

| COD | DIMENSIONI SIZES | PORTATA MAX. MAX FLOW L/min | PRESSIONE DI ESERCIZIO WORKING PRESSURE | CARATTERISTICHE FEATURES | |
|--------------|---------------------|-----------------------------------|--|-----------------------------|---|
| SSR-X 200 AP | 1/4" | 1850 | 0 ~ 20 kgf/cm ² | | 1 |

SSF-X 200 AP - FILTRO MINI - MINI FILTER



AISI 316 L

| COD | DIMENSIONI SIZES | PORTATA MAX. MAX FLOW L/min | PRESSIONE DI ESERCIZIO WORKING PRESSURE | CARATTERISTICHE FEATURES | |
|--------------|---------------------|-----------------------------------|--|--|---|
| SSF-X 200 AP | 1/4" | 1900 | 0 ~ 20 kgf/cm ² | Filtro 40 μ - Scarico manuale Filter: 40 μ - Manual drain | 1 |

MINI SSL-X 200 AP - LUBRIFICATORE - MINI LUBRICATOR



AISI 316 L

| COD | DIMENSIONI SIZES | PORTATA MAX. MAX FLOW L/min | PRESSIONE DI ESERCIZIO WORKING PRESSURE | CARATTERISTICHE FEATURES | |
|--------------|---------------------|-----------------------------------|--|-----------------------------|---|
| SSL-X 200 AP | 1/4" | 2500 | 0 ~ 20 kgf/cm ² | | 1 |

TRATTAMENTO ARIA TIPO "X" - AIR TREATMENT UNITS - "X" TYPE

AISI 316 L - ALTA PRESSIONE - SERIE US - AISI 316 L STAINLESS STEEL HIGH PRESSURE - US SERIES

USFR-L-X-AP



| COD | DIMENSIONI SIZES | 🛒 |
|----------------|---------------------|---|
| USFR-L-X 02-AP | G 1/4" | 1 |
| USFR-L-X 03-AP | G 3/8" | 1 |
| USFR-L-X 04-AP | G 1/2" | 1 |
| USFR-L-X 06-AP | G 3/4" | 1 |
| USFR-L-X 08-AP | G 1" | 1 |

AISI 316 L

USFR-X-AP



| COD | DIMENSIONI SIZES | 🛒 |
|--------------|---------------------|---|
| USFR-X 02-AP | G 1/4" | 1 |
| USFR-X 03-AP | G 3/8" | 1 |
| USFR-X 04-AP | G 1/2" | 1 |
| USFR-X 06-AP | G 3/4" | 1 |
| USFR-X 08-AP | G 1" | 1 |

AISI 316 L

USR-X-AP



| COD | DIMENSIONI SIZES | 🛒 |
|-------------|---------------------|---|
| USR-X 02-AP | G 1/4" | 1 |
| USR-X 03-AP | G 3/8" | 1 |
| USR-X 04-AP | G 1/2" | 1 |
| USR-X 06-AP | G 3/4" | 1 |
| USR-X 08-AP | G 1" | 1 |

AISI 316 L

USF-X-AP



| COD | DIMENSIONI SIZES | 🛒 |
|-------------|---------------------|---|
| USF-X 02-AP | G 1/4" | 1 |
| USF-X 03-AP | G 3/8" | 1 |
| USF-X 04-AP | G 1/2" | 1 |
| USF-X 06-AP | G 3/4" | 1 |
| USF-X 08-AP | G 1" | 1 |

AISI 316 L

USL-X-AP



| COD | DIMENSIONI SIZES | 🛒 |
|-------------|---------------------|---|
| USL-X 02-AP | G 1/4" | 1 |
| USL-X 03-AP | G 3/8" | 1 |
| USL-X 04-AP | G 1/2" | 1 |
| USL-X 06-AP | G 3/4" | 1 |
| USL-X 08-AP | G 1" | 1 |

AISI 316 L

| | | |
|--|--|--|
| | | |
| | | |
| | | |
| | | |

ACCESSORI - ACCESSORIES

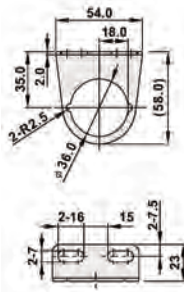

A - TYPE

🛒 €

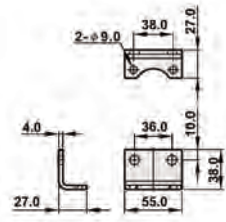

B - TYPE

🛒 €

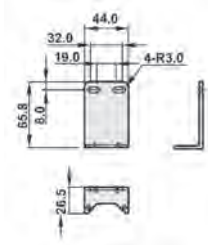

C - TYPE

🛒 €

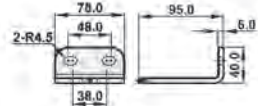

D - TYPE

🛒 €

GRUPPO TRATTAMENTO ARIA COMPRESSA - COMPRESSED AIR TREATMENT GROUP

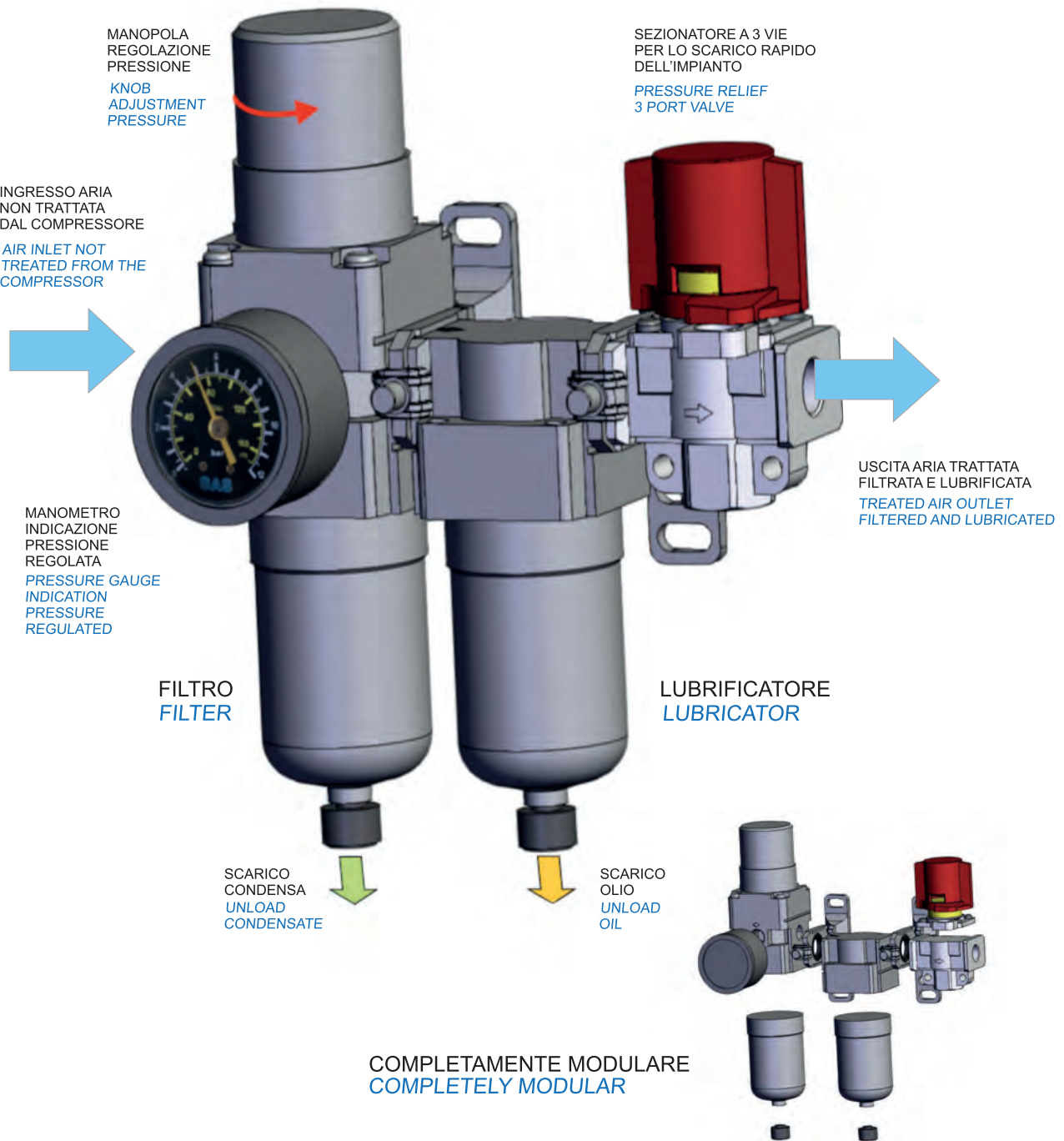

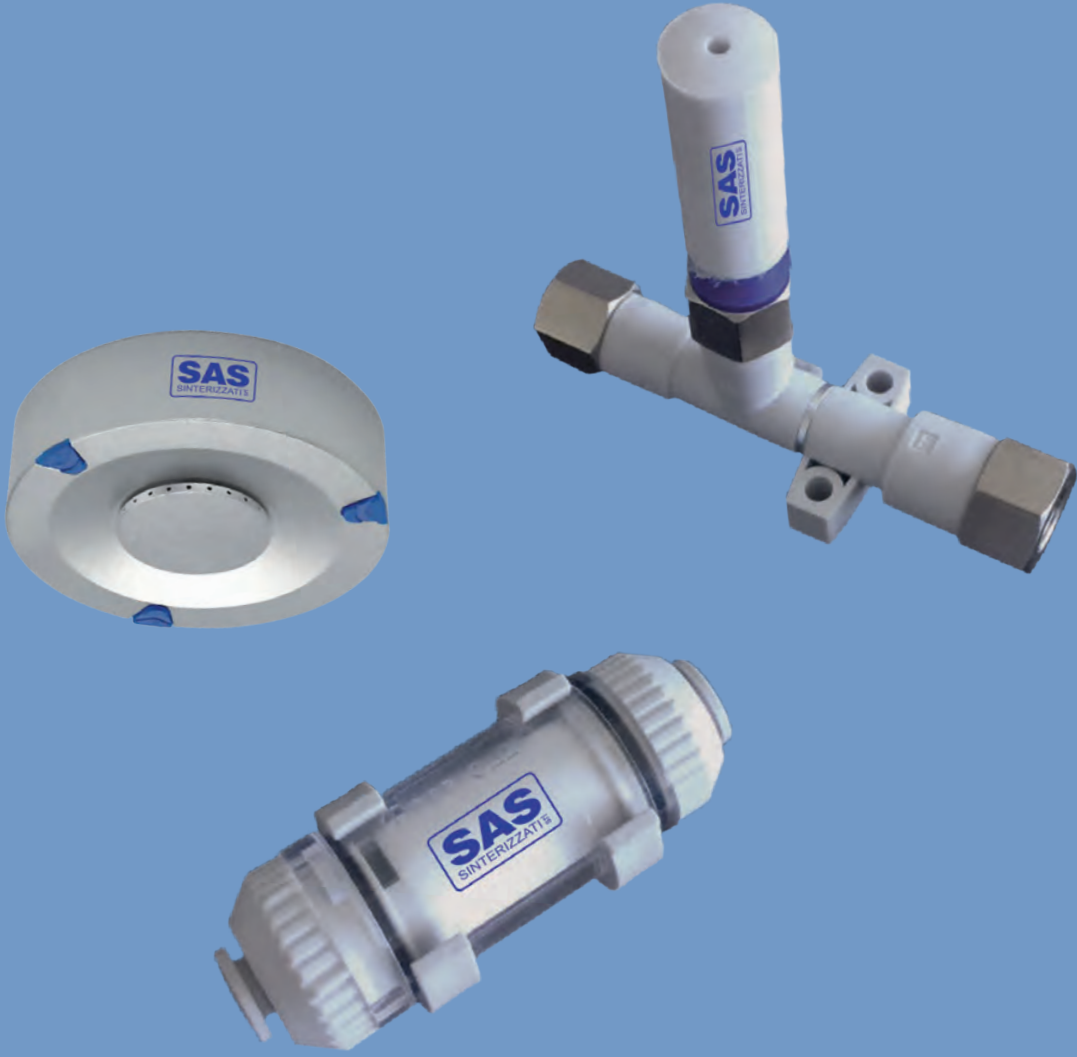

VACUUM

VACUUM - VACUUM

SZH STANDARD (FILETTATO - THREADED)



| COD | ARIA ASPIRATA SUCTION FLOW (L / min) | VUOTO FINALE MAX VACUUM CAPABILITY (KPA) | 🛒 |
|----------|--|---|---|
| SZH 05 F | 4 | 88 | 1 |
| SZH 07 F | 12 | 88 | 1 |
| SZH 10 F | 24 | 88 | 1 |
| SZH 13 F | 40 | 88 | 1 |
| SZH 15 F | 60 | 88 | 1 |
| SZH 18 F | 70 | 88 | 1 |
| SZH 20 F | 85 | 88 | 1 |

SZH STANDARD (RAPIDO - QUICK FITTING)



| COD | ARIA ASPIRATA SUCTION FLOW (L / min) | VUOTO FINALE MAX VACUUM CAPABILITY (KPA) | 🛒 |
|----------|--|---|---|
| SZH 05 R | 4 | 88 | 1 |
| SZH 07 R | 12 | 88 | 1 |
| SZH 10 R | 24 | 88 | 1 |
| SZH 13 R | 40 | 88 | 1 |
| SZH 15 R | 60 | 88 | 1 |
| SZH 18 R | 70 | 88 | 1 |
| SZH 20 R | 85 | 88 | 1 |

SZH BOX (FILETTATO - BS/BL / BS/BL - (THREADED))



| COD | ARIA ASPIRATA SUCTION FLOW (L / min) | VUOTO FINALE MAX VACUUM CAPABILITY (KPA) | 🛒 |
|-------------|--|---|---|
| SZH 05 BS F | 5 | 88 | 1 |
| SZH 07 BS F | 12 | 88 | 1 |
| SZH 10 BS F | 24 | 88 | 1 |
| SZH 13 BS F | 40 | 88 | 1 |
| SZH 05 BL F | 5 | 48 | 1 |
| SZH 07 BL F | 12 | 48 | 1 |
| SZH 10 BL F | 24 | 48 | 1 |
| SZH 13 BL F | 40 | 48 | 1 |

SZH BOX (RAPIDO) - BS/BL / BS/BL - (QUICK FITTING)



| COD | ARIA ASPIRATA SUCTION FLOW (L / min) | VUOTO FINALE MAX VACUUM CAPABILITY (KPA) | 🛒 |
|-------------|--|---|---|
| SZH 05 BS R | 9 | 88 | 1 |
| SZH 07 BS R | 22 | 88 | 1 |
| SZH 10 BS R | 34 | 88 | 1 |
| SZH 13 BS R | 75 | 88 | 1 |
| SZH 05 BL R | 9 | 48 | 1 |
| SZH 07 BL R | 22 | 48 | 1 |
| SZH 10 BL R | 34 | 48 | 1 |
| SZH 13 BL R | 75 | 48 | 1 |

SZU STANDARD (S/L) - SZU STANDARD



| COD | ARIA ASPIRATA SUCTION FLOW (L / min) | VUOTO FINALE MAX VACUUM CAPABILITY (KPA) | 🛒 |
|----------|--|---|---|
| SZU 05 S | 7 | 85 | 1 |
| SZU 05 L | 12 | 48 | 1 |
| SZU 07 S | 12 | 85 | 1 |
| SZU 07 L | 21 | 48 | 1 |

SCV - SCV



| COD | ARIA ASPIRATA SUCTION FLOW (L / min) | VUOTO FINALE MAX VACUUM CAPABILITY (KPA) | 🛒 |
|--------|--|---|---|
| SCV 05 | 7 | 92 | 1 |
| SCV 10 | 27 | 92 | 1 |
| SCV 15 | 83 | 92 | 1 |
| SCV 20 | 110 | 92 | 1 |
| SCV 25 | 160 | 92 | 1 |
| SCV 30 | 225 | 92 | 1 |

SCF - FILTRO PER VUOTO - SCF - FILTER



| COD | Ø IN / OUT PER TUBO IN / OUT TUBE Ø | PORTATA FLOW (L / min) | 🛒 |
|------------|--|------------------------------|---|
| SCF 050-23 | 3,2 | 4 | 1 |
| SCF 050-04 | 4 | 6 | 1 |
| SCF 100-04 | 4 | 10 | 1 |
| SCF 100-06 | 6 | 20 | 1 |
| SCF 200-06 | 6 | 30 | 1 |
| SCF 200-08 | 8 | 50 | 1 |

SPV - SILENZIATORE PER VUOTO - SPV - SILENCER



| COD | | 🛒 |
|-------|------|----|
| 1 SPV | 1/8" | 25 |
| 2 SPV | 1/4" | 25 |
| 3 SPV | 3/8" | 10 |
| 4 SPV | 1/2" | 10 |
| 5 SPV | 3/4" | 5 |
| 6 SPV | 1" | 5 |

Nylon + PE-HD - Nylon + PE-HD

SBS - UNITÀ DI PRESA SENZA CONTATTO - SBS - NO CONTACT BRIDGE



| COD | FORZA SOLLEVAMENTO (N) LIFTING FORCE (N) | CONSUMO D'ARIA (L / min) AIR CONSUPTION (L / min) | 🛒 |
|-----------------|---|--|---|
| SBS 20 SF M5 | 2,0 | 100 | 1 |
| SBS 20 HF M5 | 3,0 | 140 | 1 |
| SBS 30 SF M5 | 4,0 | 100 | 1 |
| SBS 30 HF M5 | 5,0 | 140 | 1 |
| SBS 40 SF 1/8" | 6,5 | 100 | 1 |
| SBS 40 HF 1/8" | 10,5 | 190 | 1 |
| SBS 60 SF 1/8" | 13,5 | 150 | 1 |
| SBS 60 HF 1/8" | 18,5 | 225 | 1 |
| SBS 100 SF 1/4" | 46,0 | 225 | 1 |
| SBS 100 HF 1/4" | 55,5 | 420 | 1 |
| SBS 120 SF 1/4" | 89,0 | 225 | 1 |
| SBS 120 HF 1/4" | 104,0 | 420 | 1 |

SCP



| COD | ARIA ASPIRATA SUCTION FLOW (L / min) | VUOTO FINALE MAX VACUUM CAPABILITY (KPA) | DIM. SIZES | 🛒 |
|---------|--|---|---------------|---|
| SCP 250 | 280-125 | 17-84 | 1/4" | 1 |
| SCP 375 | 846-395 | 17-84 | 3/8" | 1 |
| SCP 500 | 1695-650 | 17-84 | 1/2" | 1 |
| SCP 750 | 3390-1130 | 17-84 | 3/4" | 1 |

Generatore di vuoto monostadio regolabile
Adjustable single-stage vacuum generator

SCPF



| COD | ARIA ASPIRATA SUCTION FLOW (L / min) | VUOTO FINALE MAX VACUUM CAPABILITY (KPA) | DIM. SIZES | 🛒 |
|----------|--|---|---------------|---|
| SCPF 2-3 | 295 | 26 | 1/8" | 1 |
| SCPF 3-3 | 425 | 16 | 1/8" | 1 |
| SCPF 5-6 | 870 | 35 | 1/4" | 1 |
| SCPF 7-6 | 1825 | 28 | 3/8" | 1 |
| SCPF15-3 | 4400 | 4,4 | 3/8" | 1 |
| SCPF15-6 | 5610 | 9 | 3/8" | 1 |

Generatore di vuoto monostadio
Single stage vacuum generator

SM



| COD | ARIA ASPIRATA SUCTION FLOW (L / min) | VUOTO FINALE MAX VACUUM CAPABILITY (KPA) | 🛒 |
|--------------|--|---|---|
| SM 25L-AD-N | 360 | 92 | 1 |
| SM 50L-AD-N | 600 | 92 | 1 |
| SM 75L-AD-N | 760 | 92 | 1 |
| SM 100L-AD-N | 850 | 92 | 1 |
| SM 125L-AD-N | 1150 | 92 | 1 |
| SM 150L-AD-N | 1200 | 92 | 1 |

Generatore di vuoto multistadio
Multistage vacuum generator

SMC



| COD | ARIA ASPIRATA SUCTION FLOW (L / min) | VUOTO FINALE MAX VACUUM CAPABILITY (KPA) | 🛒 |
|----------------|--|---|---|
| SMC 25 L-CA-R | 360 | 75 | 1 |
| SMC 50 L-CA-R | 710 | 75 | 1 |
| SMC 75 L-CA-R | 1050 | 75 | 1 |
| SMC 100 L-CA-R | 1410 | 75 | 1 |
| SMC 125 L-CA-R | 1500 | 75 | 1 |
| SMC 150 L-CA-R | 1690 | 75 | 1 |
| SMC 25 H-CA-R | 354 | 95 | 1 |
| SMC 50 H-CA-R | 700 | 95 | 1 |
| SMC 75 H-CA-R | 980 | 95 | 1 |
| SMC 100 H-CA-R | 1380 | 95 | 1 |
| SMC 125 H-CA-R | 1480 | 95 | 1 |
| SMC 150 H-CA-R | 1650 | 95 | 1 |

Generatore di vuoto multistadio - Versione a cartuccia
Multistage vacuum generator - Cartridge version

SBM



| COD | ARIA ASPIRATA SUCTION FLOW (L / min) | VUOTO FINALE MAX VACUUM CAPABILITY (KPA) | DIM. SIZES | 🛒 |
|------------|--|---|---------------|---|
| SBM 5-B | 35-37 | 85 | 3/8" | 1 |
| SBM 5-NB | 35-37 | 85 | 3/8" NPSF | 1 |
| SBM 5-C | 35-37 | 85 | 3/8" | 1 |
| SBM 5-NC | 35-37 | 85 | 1/8" NPSF | 1 |
| SBM 5-NBA | 35-37 | 85 | 3/8" NPSF | 1 |
| SBM 5-BA | 35-37 | 85 | 3/8" | 1 |
| SBM 10-A | 70-75 | 85 | 1/8" | 1 |
| SBM 10-NA | 70-75 | 85 | 1/8" NPSF | 1 |
| SBM 10-B | 70-75 | 85 | 3/8" | 1 |
| SBM 10-NB | 70-75 | 85 | 3/8" NPSF | 1 |
| SBM 10-C | 70-75 | 85 | 3/8" | 1 |
| SBM 10-NC | 70-75 | 85 | 3/8" NPSF | 1 |
| SBM 10-NBA | 70-75 | 85 | 3/8" NPSF | 1 |
| SBM 10-BA | 70-75 | 85 | 3/8" | 1 |
| SBM 20-B | 141-150 | 85 | 3/8" | 1 |
| SBM 20-NB | 141-150 | 85 | 3/8" NPSF | 1 |
| SBM 20-C | 141-150 | 85 | 3/8" | 1 |
| SBM 20-NC | 141-150 | 85 | 3/8" NPSF | 1 |
| SBM 20-NBA | 141-150 | 85 | 3/8" NPSF | 1 |
| SBM 20-BA | 141-150 | 85 | 3/8" | 1 |
| SBM 30-B | 175-220 | 85 | 3/8" | 1 |
| SBM 30-NB | 175-220 | 85 | 3/8" NPSF | 1 |
| SBM 30-C | 175-220 | 85 | 3/8" | 1 |
| SBM 30-NC | 175-220 | 85 | 3/8" NPSF | 1 |
| SBM 30-NBA | 175-220 | 85 | 3/8" NPSF | 1 |
| SBM 30-BA | 175-220 | 85 | 3/8" | 1 |

Generatore di vuoto multistadio - Con silenziatore interno e regolazione di portata
Multistage vacuum generator - With internal silencer and flow regulation

SZK



| COD | ARIA ASPIRATA SUCTION FLOW (L / min) | VUOTO FINALE MAX VACUUM CAPABILITY (KPA) | DIM. SIZES | 🛒 |
|----------|--|---|---------------|---|
| SZK-X-NE | 41 | 93 | Ø 6 | 1 |
| SZK-P-NE | 40 | 90 | Ø 6 | 1 |
| SZK-D-NE | 38 | 71 | Ø 6 | 1 |
| SZK-S-N | 40 | 75 | Ø 6 | 1 |
| SZK-X-N | 41 | 93 | Ø 6 | 1 |
| SZK-P-N | 40 | 90 | Ø 6 | 1 |
| SZK-D-N | 38 | 71 | Ø 6 | 1 |
| SZK-S | 40 | 75 | Ø 6 | 1 |
| SZK-X | 41 | 93 | Ø 6 | 1 |
| SZK-P | 40 | 90 | Ø 6 | 1 |
| SZK-D | 38 | 71 | Ø 6 | 1 |
| SZK-L | 68 | 90 | Ø 8 | 1 |
| SZK-L-N | 68 | 90 | Ø 8 | 1 |

Generatore di vuoto eiettore con valvola e pressostato
Vacuum generator ejector with valve and pressure switch



VENTOSE - SUCTION CUPS

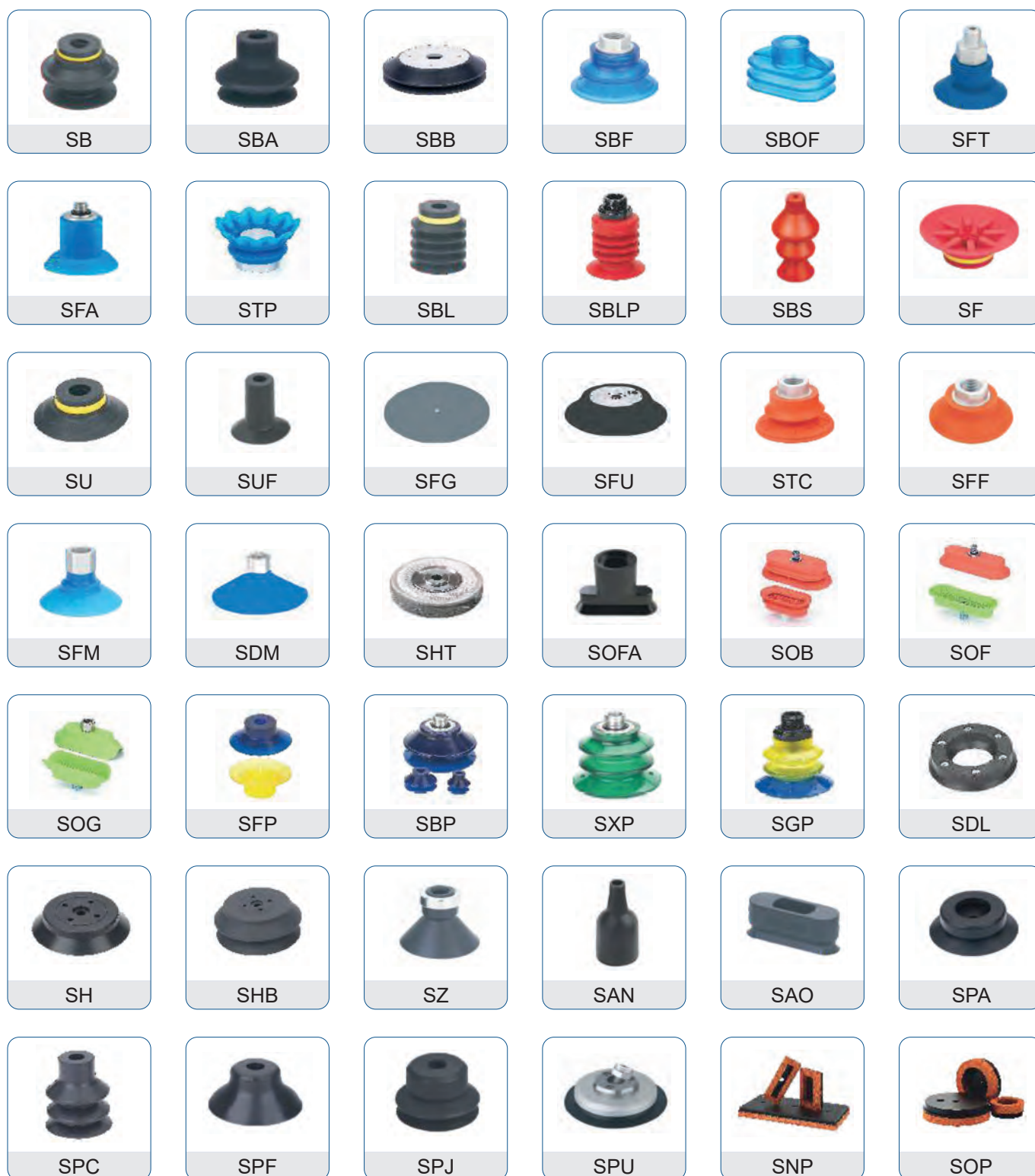

Per maggiori informazioni e chiarimenti consultare il relativo Fascicolo Tecnico.
For further information and clarifications, consult the relevant Technical File.

Prezzi di listino e informazioni tecniche relative a questi prodotti sono disponibili a richiesta.
Prices and technical information relating to these products are available on request.

FILTRO UNIVERSALE PER VUOTO

SCF

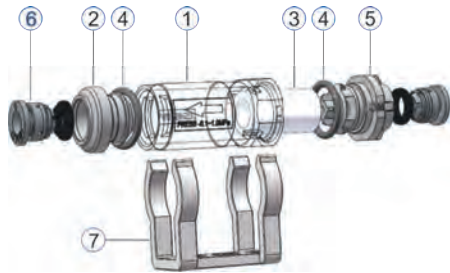

COMPONENTI

| N. | Particolare | Materiale | Quantità |
|----|--------------------|-----------|----------|
| 1 | Corpo filtro | PC | 1 |
| 2 | Tappo posteriore | PBT | 1 |
| 3 | Elemento filtrante | PE | 1 |
| 4 | O-ring | NBR | 2 |
| 5 | Tappo anteriore | PBT | 1 |
| 6 | Raccordo rapido | // | 2 |
| 7 | Staffa / Supporto | PBT | 1 |

KIT DI MANUTENZIONE



ATTREZZO



ELEMENTO FILTRANTE

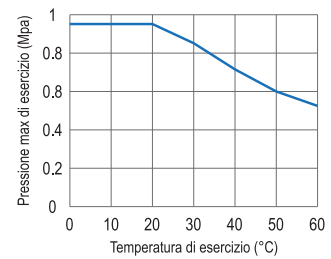

SOSTITUZIONE ELEMENTO FILTRANTE

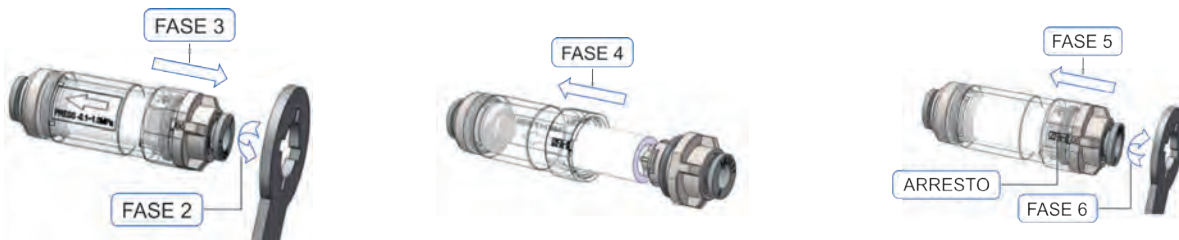

MODALITÀ

- 1) Interrompere l'alimentazione d'aria e portare la pressione nel filtro fino alla pressione atmosferica.
- 2) Ruotare con la chiave il tappo anteriore di 90° in senso anti orario.
- 3) Togliere il tappo anteriore, estrarre l'elemento filtrante e, se all'interno della custodia è presente della polvere, eliminarla con un getto d'aria.
- 4) Installare un nuovo elemento filtrante inserendolo nell'apposita sede.
- 5) Allineare il lato senza numero del tappo anteriore col riferimento riportato sulla custodia e spingerlo fino a battuta.
- 6) Ruotare il tappo con la chiave in senso orario fino all'arresto (allineando il numero con la marcatura di riferimento).

AVVERTENZE

- 1) Quando si collega il tubo, controllare la freccia che indica la direzione del flusso. In caso di collegamento errato, la tenuta dell'aria dell'elemento filtrante non può essere garantita.
- 2) Sulla stessa linea d'aria la pressione positiva e quella negativa non possono essere utilizzate contemporaneamente.
- 3) Assicurarsi di non danneggiare l'O-ring durante le operazioni di montaggio e di smontaggio. Si raccomanda inoltre di verificare che non ci siano perdite d'aria dopo la sostituzione del filtro.
- 4) Il filtro del vuoto ed il tubo non devono essere sottoposti a forze esterne come torsione, trazione, carico, vibrazioni, urti, ecc. Ciò potrebbe essere pericoloso ad alte pressioni di utilizzo.
- 5) Dopo avere sostituito l'elemento filtrante verificare l'allineamento della struttura anti rotazione con il riferimento riportato sulla custodia.
- 6) Utilizzare il filtro alla pressione di esercizio nominale.
- 7) L'utilizzo dell'aria compressa può essere pericoloso. Pertanto la sostituzione del filtro ed altri tipi di manutenzione devono essere eseguiti da personale con adeguata conoscenza ed esperienza della meccanica.

UNIVERSAL VACUUM FILTER

SCF

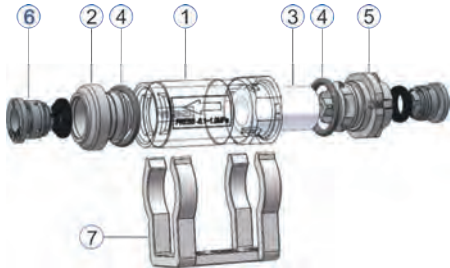

| COMPONENTS | | | |
|------------|-------------------|----------|----------|
| No. | Item | Material | Quantity |
| 1 | Housing | PC | 1 |
| 2 | Rear cap | PBT | 1 |
| 3 | Filter element | PE | 1 |
| 4 | O-ring | NBR | 2 |
| 5 | Front cap | PBT | 1 |
| 6 | One-touch fitting | // | 2 |
| 7 | Bracket | PBT | 1 |

REPAIR KIT



TOOL



FILTER ELEMENT



| Operating Temperature (°C) | Max Operating Pressure (MPa) |
|----------------------------|------------------------------|
| 0 | 1.0 |
| 10 | 1.0 |
| 20 | 1.0 |
| 30 | 0.9 |
| 40 | 0.8 |
| 50 | 0.7 |
| 60 | 0.6 |

FILTER ELEMENT REPLACEMENT

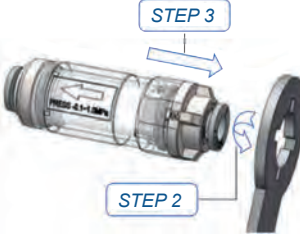

STEP 2

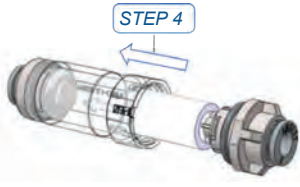

STEP 3

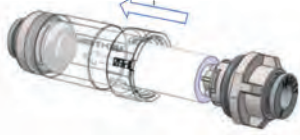

STEP 4

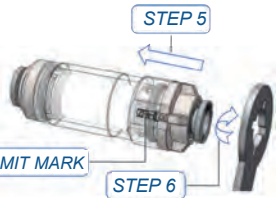

STEP 5



STEP 6

HOW TO OPERATE

- 1) Stop supplying air and reduce the pressure in the vacuum filter to atmospheric pressure.
- 2) Put tool on the front cap and turn it 90° anti-clockwise.
- 3) Pull out the front cap, remove the filter element, and if there is dust inside the housing, clean it with an air gun (make sure that it does not damage the O-ring).
- 4) Install new filter element on the front cap and insert it into the housing.
- 5) Align the unnumbered side of the front cap with the reference on the case and push it in until it stops.
- 6) Rotate clockwise with the tool until it stops (align the number at the limit mark).

CAUTIONS

- 1) When connecting the hose, check the arrow indicating the flow direction. If reverse connecting, airtightness of the filter element cannot be ensured.
- 2) In one air line, positive and negative pressure should not be used at the same time.
- 3) Please make sure not to damage the O-ring during assembling and disassembling. And please confirm that there is no air leakage after the filter element is replaced.
- 4) The vacuum filter and hose shall not withstand external force such as torsion, pull, load, vibration, impact, etc., and external force may cause danger at high positive pressure.
- 5) There is anti-rotating structure at the limit mark. After replacing the filter element, please confirm the position of the limit mark.
- 6) Please use vacuum filter at rated working pressure.
- 7) Compressed air operation may cause danger. Therefore the replacement of the filter and other types of maintenance must be performed by personnel with adequate knowledge and experience of air mechanics.

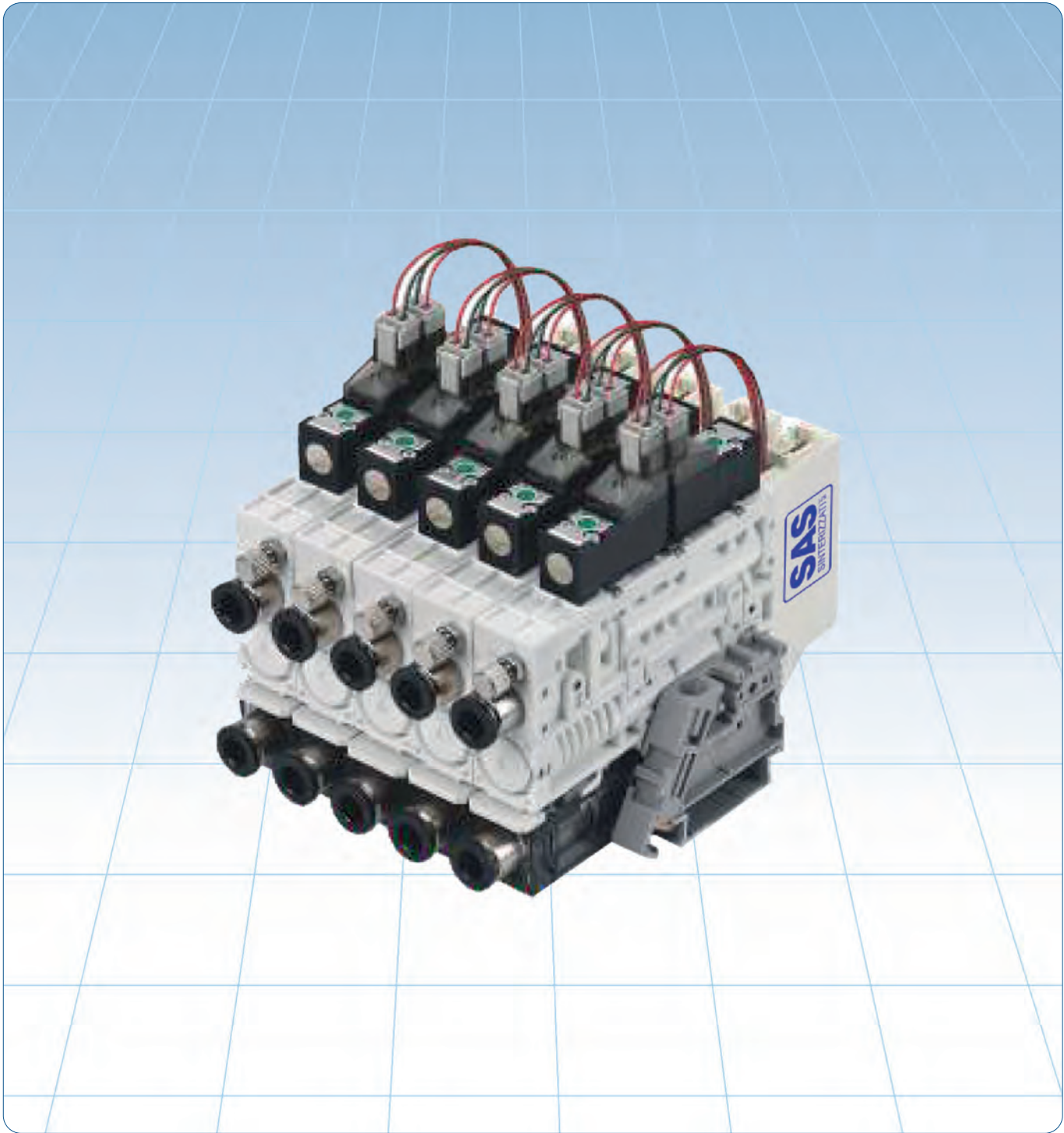

Per maggiori chiarimenti e specifiche consultare il relativo Fascicolo Tecnico.
For further clarifications and specifications, consult the relevant Technical File.

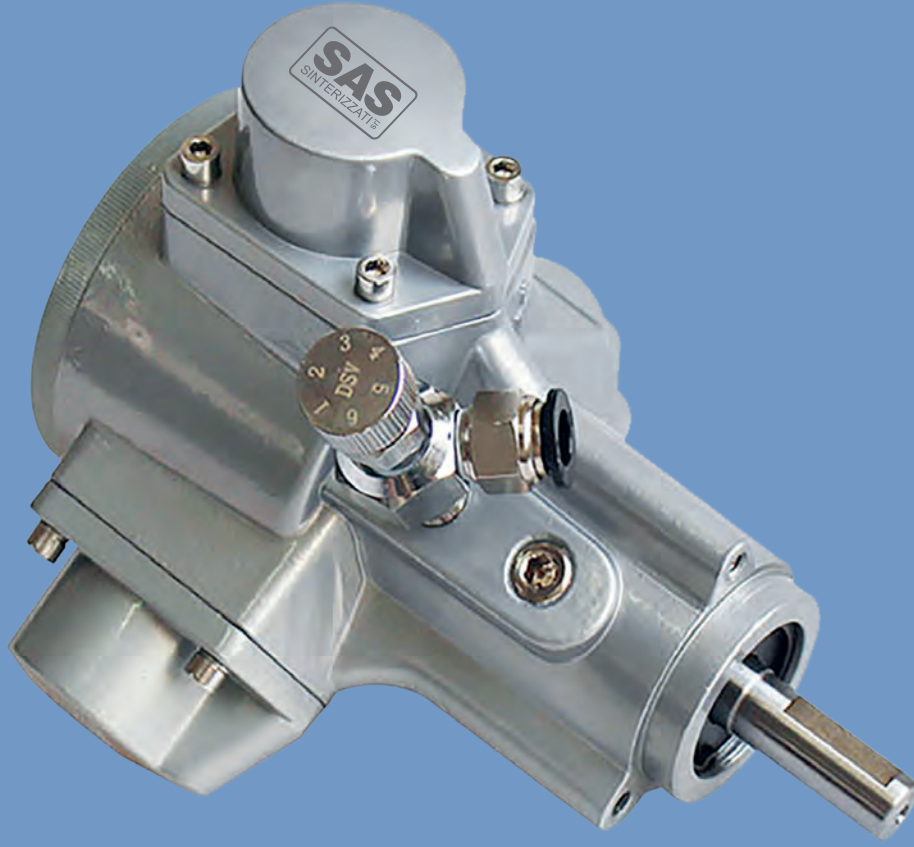

AIR MOTORS

| | | | | | |
|---|--------------|-----|--|------------------|-----|
|  | S DAM 1 | 295 |  | S HX 2 AM F 110 | 296 |
|  | S DAM 3 | 295 |  | S HX 2 AM F114-3 | 296 |
|  | S DAM 5 | 295 |  | S HX 4 AM H | 296 |
|  | S DAM 7 | 295 |  | S HX 4 AM V | 296 |
|  | S DAM 110 | 295 |  | S HX 4 AM F110 | 297 |
|  | S DAM 210 | 295 |  | S HX 4 AM-F114-3 | 297 |
|  | S HX1AM V | 296 |  | S HX 6 AM H | 297 |
|  | S HX1 UP NCW | 296 |  | S HX 6 AM V | 297 |
|  | S HX1 UP NRV | 296 |  | S HX 6 AM ARV-54 | 297 |
|  | S HX 2 AM H | 296 |  | S HX 6 AM F114.3 | 297 |
|  | S HX 2 AM V | 296 |  | S HX 8 AM H | 297 |

| | | | | | |
|---|----------------------|-----|---|--------------------|-----|
|  | S HX 8 AM V | 297 |  | S HX 4AM-RV-15 | 298 |
|  | S HX 8 AM ARV-70 | 297 |  | S HX WG 01 | 298 |
|  | S HX 8 AM F114.3 | 297 |  | S HX WG 02 | 298 |
|  | S HX 16 AM FRV-13 | 297 |  | S HX 1AM-V-S-113 | 299 |
|  | S HX 16 AM FRV-2 | 297 |  | S HX 1AM-VF-S-113 | 299 |
|  | S HX NL 32 | 298 |  | S HX 1AM-V-S-127 | 299 |
|  | S HX NL 42 | 298 |  | S HX 4AM-NRV-251SS | 299 |
|  | S HX NL 52 | 298 |  | AIR FAN | 299 |
|  | S HX 1AM-NRV-95-GR15 | 298 |  | AIR HOIST | 299 |
|  | S HX 1UP-NRV-16-GR15 | 298 |  | AIR LAMP | 299 |
|  | S HX 4AM-RV-10 | 298 |  | GPE | 300 |

| MOTORI AD ARIA A PISTONE - PISTON AIR MOTORS | | | | | | | | | | | |
|--|--|------------------------|------------------------|-----------------------------|--|--|------------------------------------|--|----------------------------------|--------------------------------|----------------------------------|
| COD | RAPPORTO DI TRASMISSIONE GEAR RATIO | POTENZA POWER HP | COPPIA TORQUE NM | VELOCITÀ SPEED R.P.M. | VELOCITÀ LIBERA MAX. MAX FREE SPEED R.P.M. | CONSUMO ARIA AIR CONSUPTION R.P.M. | STOP COPPIA STOP TORQUE N.m. | COPPIA DI SPUNTO START TORQUE N.m. | MODELLO BASE BASIC TYPE Kg | TIPO LANGE LANGE TYPE Kg | TIPO DI PIEDE FOOT TYPE Kg |
| S DAM 1 | 1:1 | 1/8 | 0,637 | 1100 | 2200 | 202 | 1,18 | 0,686 | 1,6 | 1,84 | 2,1 |
| | G 1/5 | | 2,84 | 220 | | | 4,90 | 2,94 | | 4,0 | 3,5 |
| | G 1/10 | | 5,69 | 110 | | | 9,81 | 5,88 | | | |
| | G 1/15 | | 8,53 | 73,3 | | | 15,7 | 8,83 | | | |
| | G 1/20 | | 11,5 | 55 | | | 20,6 | 11,8 | | | |
| S DAM 3 | 1:1 | 1/4 | 1,37 | 900 | 1800 | 259 | 2,94 | 1,96 | 2,7 | 3,12 | 3,6 |
| | G 1/5 | | 5,88 | 180 | | | 12,7 | 8,83 | | 2,7 | 6,7 |
| | G 1/10 | | 11,8 | 90 | | | 26,5 | 17,7 | | | |
| | G 1/15 | | 17,7 | 60 | | | 39,2 | 26,5 | | | |
| | G 1/20 | | 23,5 | 45 | | | 53 | 35,3 | | | |
| | G 1/30 | | 35,3 | 30 | | | 78,5 | 53,0 | | | |
| | G 1/40 | | 47,1 | 22,5 | | | 106 | 70,6 | | | |
| | G 1/50 | | 58,8 | 18 | | | 132 | 79,4 | | | |
| | G 1/60 | | 70,6 | 15 | | | 157 | 106 | | | |
| | G 1/80 | | 93,2 | 11,2 | | | 206 | 139 | | | |
| | G 1/100 | | 118 | 9 | | | 250 | 175 | | | |
| | G 1/120 | | 137 | 7,5 | | | 300 | 206 | | | |
| | G 1/160 | | 176 | 5,6 | | | 373 | 261 | | | |
| | G 1/200 | | 233 | 4,5 | | | 500 | 305 | 11,7 | | 11,2 |
| S DAM 5 | 1:1 | 1/2 | 2,94 | 750 | 1500 | 397 | 5,88 | 4,71 | 4,9 | 5,47 | 6,6 |
| | G 1/5 | | 12,7 | 150 | | | 26,5 | 20,6 | 4,9 | 10,5 | 10,0 |
| | G 1/10 | | 26,5 | 75 | | | 53,0 | 14,2 | | | |
| | G 1/15 | | 39,2 | 50 | | | 79,4 | 61,8 | | | |
| | G 1/20 | | 53 | 37,5 | | | 109,6 | 82,4 | | | |
| | G 1/30 | | 78,5 | 25 | | | 159 | 124 | | | |
| | G 1/40 | | 106 | 18,7 | | | 212 | 165 | | | |
| | G 1/50 | | 132 | 15 | | | 265 | 206 | | | |
| | G 1/60 | | 157 | 12,5 | | | 318 | 247 | | | |
| | G 1/80 | | 203 | 9,3 | | | 402 | 314 | | | |
| | G 1/100 | | 250 | 7,5 | | | 490 | 392 | | | |
| | G 1/120 | | 300 | 6,2 | | | 598 | 471 | | | |
| | G 1/160 | | 396 | 4,6 | | | 785 | 628 | | | |
| G 1/200 | 500 | 3,7 | 981 | 785 | 14,0 | 13,5 | | | | | |
| S DAM 7 | 1:1 | 1,5 | 28 | 360 | 720 | 985 | 54,1 | 44,7 | / | 20 | 23 |
| | G 1/5 | | 140 | 144 | | | 243 | 201 | / | 24,0 | 26,5 |
| | G 1/10 | | 280 | 72 | | | 486 | 402 | | 30,0 | 32 |
| | G 1/15 | | 420 | 48 | | | 730 | 603 | | 38,5 | 39,5 |
| | G 1/20 | | 560 | 36 | | | 973 | 894 | | 41 | 42 |
| | G 1/30 | | 840 | 24 | | | 1460 | 1341 | | 44,5 | 46 |
| | G 1/40 | | 1120 | 18 | | | 1947 | 1609 | | 51 | 53,5 |
| S DAM 110 | 1:1 | 2,3 | 8 | 1200 | 2400 | 1680 | 12 | 9 | 13 | 17,5 | |
| S DAM 210 | 1:1 | 5,4 | 20 | 1200 | 2400 | 5100 | 34 | 27 | 26 | 36 | |

MOTORI AD ARIA A PISTONE - PISTON AIR MOTORS

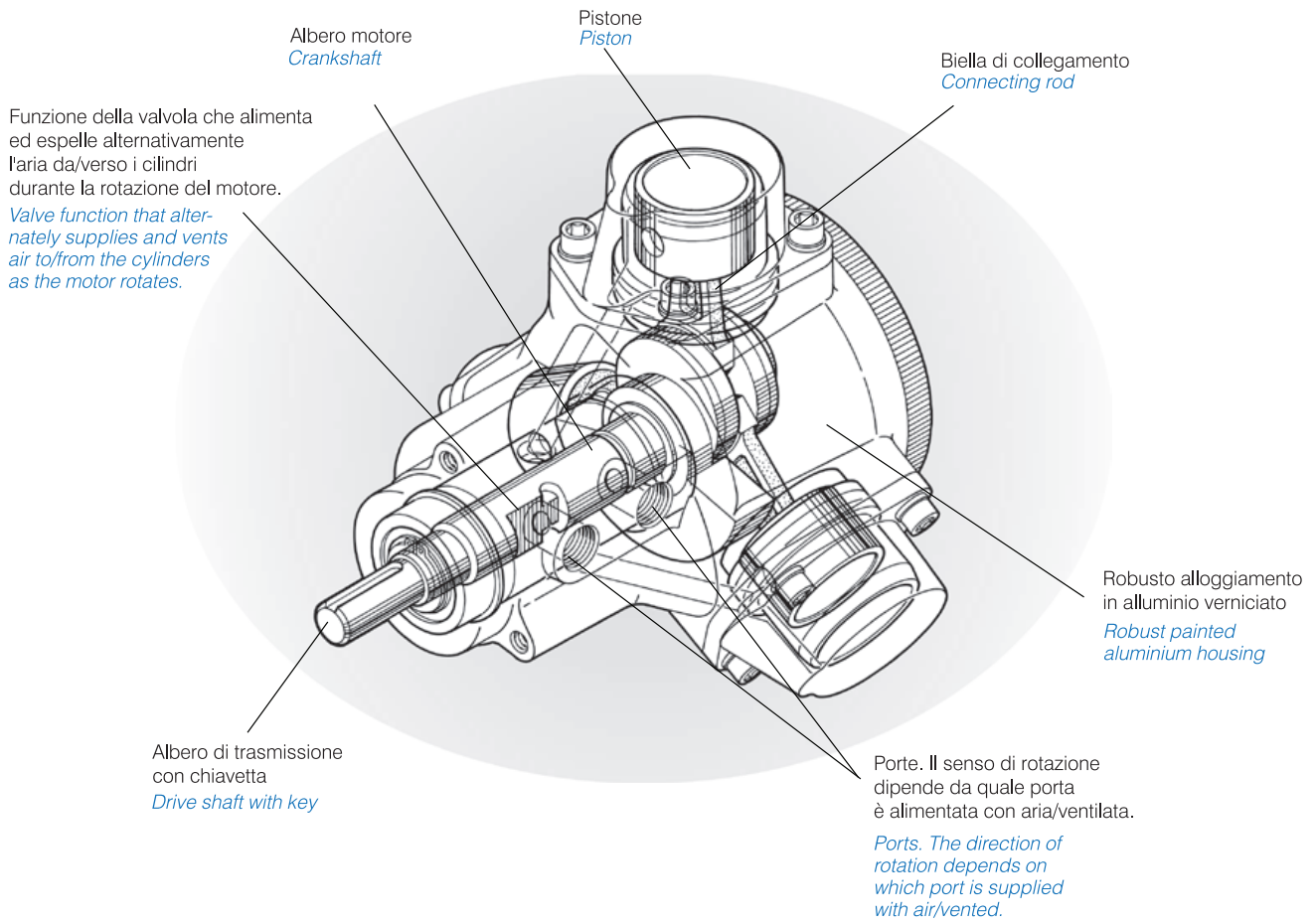

S DAM 1
 Potenza - Power HP 1/8 
 1



S DAM 3
 Potenza - Power HP 1/4 
 1



S DAM 5
 Potenza - Power HP 1/2 
 1



S DAM 7
 Potenza - Power HP 1,5 
 1



S DAM 110
 Potenza - Power HP 2,3 
 1



S DAM 210
 Potenza - Power HP 5,4 
 1



MOTORE AD ARIA A VANO - VANE AIR MOTOR

| COD | Dati di funzionamento - Operation Data | | | | | | | Coppia massima - Maximum Torque | | |
|------------|---|------|--|--------|----------------------------|--|-------|---------------------------------|------------------------------|--------|
| | Potenza di uscita massima Max Output Power | | Coppia massima in uscita Torque at max output | | Velocità max. Max Speed | Consumo massimo di aria Max Air Consumption | | Velocità max. Max Speed | Coppia massima Max Torque | |
| | hp | kw | Nm | lb.in. | rpm | m³/h | cfm | rpm | Nm | lb.in. |
| S HX 1 AM | 0,45 | 0,33 | 0,31 | 2,75 | 10000 | 35,1 | 20,5 | 650 | 0,65 | 5,60 |
| S HX 1 UP | 0,45 | 0,33 | 0,58 | 5,25 | 6000 | 47,0 | 27,0 | 500 | 0,68 | 6,00 |
| S HX 2 AM | 0,93 | 0,68 | 2,20 | 19,50 | 3000 | 49,5 | 30,0 | 350 | 3,05 | 26,10 |
| S HX 4 AM | 1,70 | 1,30 | 4,10 | 36,00 | 3000 | 132,5 | 78,0 | 300 | 6,30 | 56,00 |
| S HX 6 AM | 4,00 | 3,00 | 10,00 | 84,00 | 3000 | 228,0 | 128,0 | 300 | 13,00 | 115,00 |
| S HX 8 AM | 5,25 | 3,90 | 14,40 | 132,00 | 2500 | 293,0 | 175,0 | 300 | 21,00 | 185,00 |
| S HX 16 AM | 9,50 | 7,00 | 34,00 | 290,00 | 2500 | 475,0 | 275,0 | 300 | 43,00 | 272,00 |

S HX1AM V

Montaggio mozzo - 4 Vani - Reversibile
Hub mounting - 4 Vanes - Reversible



S HX1 UP NCW

Montaggio mozzo - 4 Vani - CW
Hub mounting - 4 Vanes - CW



S HX1 UP NRV

Montaggio mozzo - 4 Vani - Reversibile
Hub mounting - 4 Vanes - Reversible



S HX 2 AM H

Montaggio a pedale - 4 Vani - Reversibile
Foot mounting - 4 Vanes - Reversible



S HX 2 AM V

Montaggio a pedale - 4 Vani - Reversibile
Hub & Face mounting - 4 Vanes - Reversible



S HX 2 AM F 110

Flangia IEC - 4Vani - Reversibile
IEC flange - 4Vanes - Reversible



S HX 2 AM F114-3

Flangia NEMA - 4 Vani - Reversibile
NEMA flange - 4 Vanes - Reversible



S HX 4 AM H

Foot mounting - 4 Vanes - Reversibile
Montaggio a pedale - 4 Vani - Reversibile



S HX 4 AM V

Montaggio frontale - 4 Vani - Reversibile
Face mounting - 4 Vanes - Reversible





S HX 4 AM F110
 Flangia IEC - 4 Vani - Reversibile 
IEC flange - 4 Vanes - Reversible 1





S HX 4 AM-F114-3
 Flangia NEMA - 4 Vani - Reversibile 
NEMA flange - 4 Vanes - Reversible 1



S HX 6 AM H
 Montaggio frontale - 4 Vani - Reversibile 
Face mounting - 4 Vanes - Reversible 1





S HX 6 AM V
 Montaggio frontale - 4 Vani - Reversibile 
Face mounting - 4 Vanes - Reversible 1





S HX 6 AM ARV-54
 Montaggio su flangia IEC - 4 Vani - Reversibile 
IEC flange mounting - 4 Vanes - Reversible 1





S HX 6 AM F114.3
 Flangia NEMA - 4 Vani - Reversibile 
NEMA flange - 4 Vanes - Reversible 1



S HX 8 AM H
 Montaggio a pedale - 4 Vani - Reversibile 
Foot mounting - 4 Vanes - Reversible 1





S HX 8 AM V
 Montaggio frontale - 4 Vani - Reversibile 
Face mounting - 4 Vanes - Reversible 1



S HX 8 AM ARV-70
 Montaggio su flangia IEC - 4 Vani - Reversibile 
IEC flange mounting - 4 Vanes - Reversible 1



S HX 8 AM F114.3
 Flangia NEMA - 4 Vani - Reversibile 
NEMA flange - 4 Vanes - Reversible 1



S HX 16 AM FRV-13
 Montaggio con piedini e flangia NEMA - 6 Vani - Rev. 
Foot & NEMA flange mount - 6 Vanes - Reversible 1



S HX 16 AM FRV-2
 Montaggio su piede e frontale - 6 Vani - Rev. 
Foot & face mounting - 6 Vanes - Reversible 1



MOTORE AD ARIA SENZA OLIO - OILLESS AIR MOTOR

| COD | Dati di funzionamento - <i>Operation Data</i> | | | | | | Coppia massima - <i>Maximum Torque</i> | | | |
|------------|--|------|---|--------|----------------------------------|---|--|----------------------------------|-------------------------------------|--------|
| | Potenza di uscita massima <i>Max Output Power</i> | | Coppia massima in uscita <i>Torque at max output</i> | | Velocità max <i>Max Speed</i> | Consumo massimo di aria <i>Max Air Consumption</i> | | Velocità max <i>Max Speed</i> | Coppia massima <i>Max Torque</i> | |
| | hp | kw | Nm | lb.in. | rpm | m³/h | cfm | rpm | Nm | lb.in. |
| S HX NL 32 | 0,42 | 0,31 | 1,5 | 13,5 | 2000 | 51 | 30 | 300 | 2,5 | 21 |
| S HX NL 42 | 0,82 | 0,61 | 2,9 | 25,5 | 2000 | 70 | 41 | 500 | 5,0 | 44 |
| S HX NL 52 | 2,5 | 1,86 | 8,9 | 78,75 | 2000 | 115 | 68 | 500 | 11,3 | 100 |

S HX NL 32
 Montaggio mozzo e cibo - 4 Vani - CW/CCW
 Hub & Food mounting - 4 Vanes - CW/CCW 1



S HX NL 42
 Montaggio mozzo e cibo - 4 Vani - CW/CCW
 Hub & Food mounting - 4 Vanes - CW/CCW 1



S HX NL 52
 Montaggio mozzo e cibo - 4 Vani - CW/CCW
 Hub & Food mounting - 4 Vanes - CW/CCW 1



MOTORE AD ARIA - AIR GEAR MOTOR

| COD | Rapporto di trasmissione <i>Gear ratio</i> | Dati di funzionamento - <i>Operation Data</i> | | | | | | Coppia massima - <i>Maximum Torque</i> | | | |
|----------------------|---|--|------|---|--------|----------------------------------|---|--|----------------------------------|-------------------------------------|--------|
| | | Potenza di uscita max <i>Max output power</i> | | Coppia massima in uscita <i>Torque at max output</i> | | Velocità max <i>Max Speed</i> | Consumo massimo di aria <i>Max Air Consumption</i> | | Velocità max <i>Max Speed</i> | Coppia massima <i>Max Torque</i> | |
| | | hp | kw | Nm | lb.in. | rpm | m³/h | cfm | rpm | Nm | lb.in. |
| S HX 1AM-NRV-95-GR15 | 15:1 | 0,34 | 0,26 | 7,1 | 62 | 350 | 36 | 21 | 30 | 8,1 | 72 |
| S HX 1UP-NRV-16-GR15 | 15:1 | 0,32 | 0,23 | 5,5 | 49 | 400 | 36 | 21 | 30 | 8,0 | 71 |
| S HX 4AM-RV-10 | 10:1 | 1,26 | 0,94 | 31 | 274 | 300 | 98 | 57,5 | 30 | 48 | 425 |
| S HX 4AM-RV-15 | 15:1 | 1,25 | 0,90 | 45,2 | 400 | 200 | 102 | 60 | 20 | 72 | 640 |
| S HX WG 01 | 20:1 | 0,64 | 0,48 | 21 | 172 | 110 | 34 | 20 | 12 | 28 | 240 |
| S HX WG 02 | 20:1 | 0,90 | 0,68 | 29 | 256 | 150 | 46 | 27 | 17 | 40 | 343,5 |

S HX 1AM-NRV-95-GR15
 Montaggio frontale - 4 Vani - Reversibile
 Face mounting - 4 Vanes - Reversible 1



S HX 1UP-NRV-16-GR15
 Montaggio frontale - 4 Vani - Reversibile
 Face mounting - 4 Vanes - Reversible 1



S HX 4AM-RV-10
 Montaggio su piede e frontale - 4 Vani - Rev.
 Face/foot mounting - 4 Vanes - Reversible 1



S HX 4AM-RV-15
 Montaggio su piede e frontale - 4 Vani - Rev.
 Face / foot mounting - 4 Vanes - Reversible 1



S HX WG 01
 Montaggio alla base - 4 Vani - Reversibile
 Base mounting - 4 Vanes - Reversible 1



S HX WG 02
 Montaggio alla base - 4 Vani - Reversibile
 Base mounting - 4 Vanes - Reversible 1



MOTORE AD ARIA IN ACCIAIO INOX - *STAINLESS STEEL AIR MOTOR*

| COD | Dati di funzionamento - <i>Operation Data</i> | | | | | | Coppia massima - <i>Maximum Torque</i> | | | |
|--------------------|--|------|---|--------|----------------------------------|---|--|----------------------------------|-------------------------------------|--------|
| | Potenza di uscita massima <i>Max Output Power</i> | | Coppia massima in uscita <i>Torque at max output</i> | | Velocità max <i>Max Speed</i> | Consumo massimo di aria <i>Max Air Consumption</i> | | Velocità max <i>Max Speed</i> | Coppia massima <i>Max Torque</i> | |
| | hp | kw | Nm | lb.in. | rpm | m³/h | cfm | rpm | Nm | lb.in. |
| S HX 1AM-V-S-113 | 0,45 | 0,33 | 0,31 | 2,75 | 10000 | 35,1 | 20,5 | 650 | 0,65 | 5,60 |
| S HX 1AM-VF-S-113 | 0,45 | 0,33 | 0,31 | 2,75 | 10000 | 35,1 | 20,5 | 650 | 0,65 | 5,60 |
| S HX 1AM-V-S-127 | 0,45 | 0,33 | 0,31 | 2,75 | 10000 | 35,1 | 20,5 | 650 | 0,65 | 5,60 |
| S HX 4AM-NRV-251SS | 1,70 | 1,30 | 4,1 | 36,00 | 3000 | 132,5 | 78 | 300 | 6,30 | 56,00 |

S HX 1AM-V-S-113

Montaggio frontale - 4 Vani - Reversibile 
Face mounting - 4 Vanes - Reversible 1



S HX 1AM-VF-S-113

Montaggio frontale - 4 Vani - Reversibile 
Face mounting - 4 Vanes - Reversible 1



S HX 1AM-V-S-127

Montaggio frontale - 4 Vani - Reversibile 
Face mounting - 4 Vanes - Reversible 1



S HX 4AM-NRV-251SS

Montaggio frontale - 4 Vani - Reversibile 
Face mounting - 4 Vanes - Reversible 1



ACCESSORI MOTORI AD ARIA - *AIR MOTOR ACCESSORIES*

AIR FAN

ARICHIESTA - ON REQUEST 
1

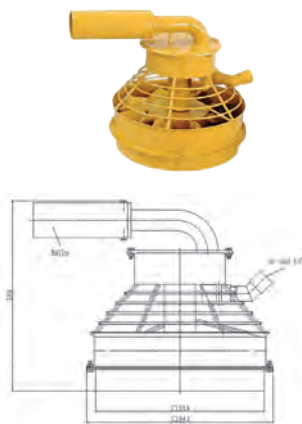

AIR HOIST

ARICHIESTA - ON REQUEST 
1

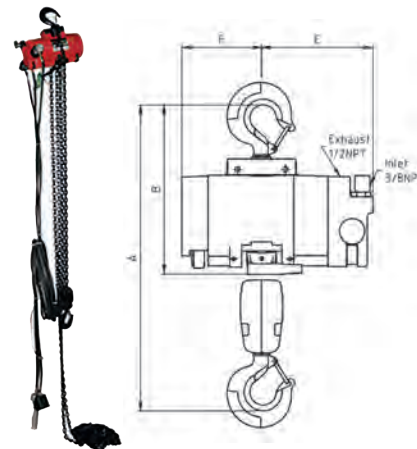

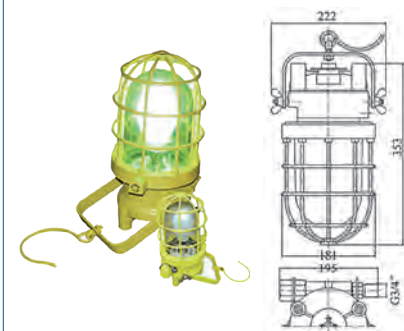

AIR LAMP

ARICHIESTA - ON REQUEST 
1

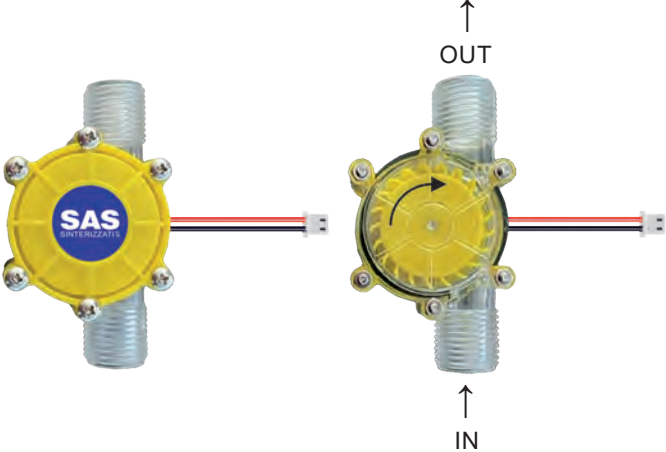

GPE - GENERATORE PNEUMO ELETTRICO - *ELECTRIC PNEUMATIC GENERATOR*



| | |
|---|---------------------------------------|
| Cod. | GPE |
| Dimensioni <i>Size</i> | 1/2" - 1/2" |
| Pressione max. <i>Max pressure</i> | 10 Bar |
| Temperatura di esercizio <i>Operating temperature</i> | - 0°C ÷ + 50°C |
| Materiale <i>Material</i> | Tecnopolimero <i>Technopolymer</i> |
| Voltaggio erogato <i>Voltage</i> | 12 VCC - 24 VCC 12 VDC - 24 VDC |
| Filettatura <i>Thread</i> | Cilindrico <i>Parallel</i> |
|  | 1 |



L' utilizzo dell' Aria Compressa consente al Sistema GPE di erogare energia elettrica al Voltaggio desiderato (ad esempio 12 Volt in C.C.) anche in caso di Black-out elettrico. Ciò permette di garantire l'alimentazione di elettrovalvole di sicurezza (al limite anche in presenza di Atmosfera esplosiva). Per ulteriori informazioni richiedere il relativo Fascicolo Tecnico e/o consultare il nostro Ufficio Tecnico.

The use of Compressed Air allows the GPE System to supply electrical energy at the desired voltage (for example 12 Volts in DC) even in the event of an electrical black-out. This allows the power supply of safety solenoid valves to be guaranteed (at the limit also in the presence of an explosive atmosphere). For further information, request the relevant Technical File and/or consult our Technical Office.



- 1 Serbatoio di compensazione 500 CC - *500 CC Compensation tank*
- 2 Generatore pneumo elettrico - *Electric Pneumatic Generator*
- 3 Power Unit - *Power Unit*

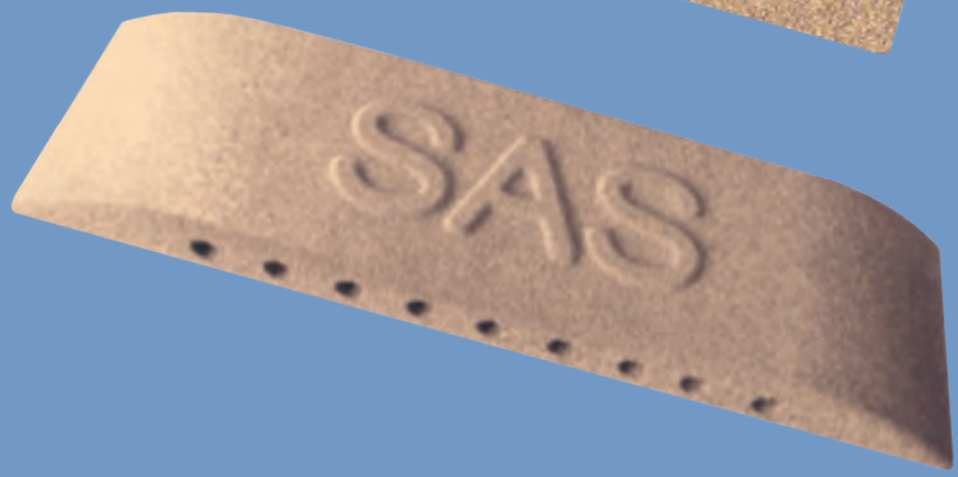
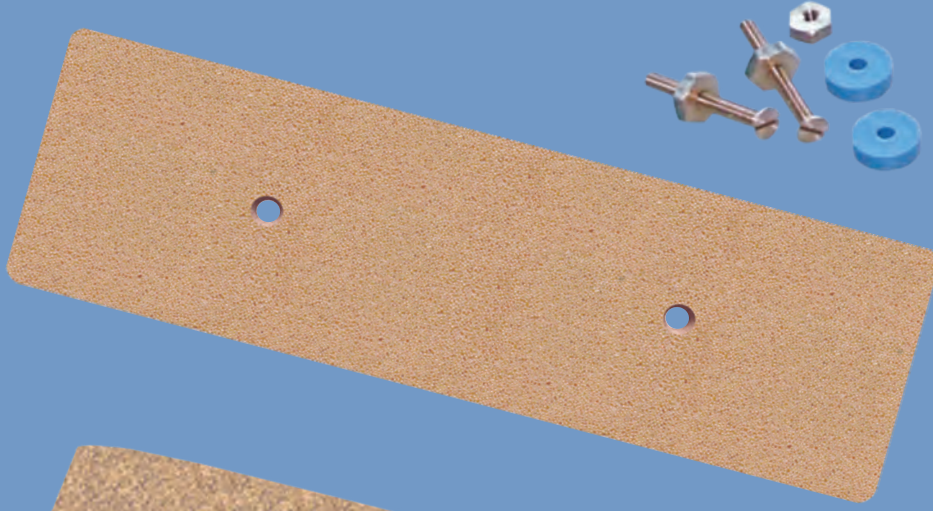

GROUND PLATES

PIASTRE DI MASSA PER USO NAUTICO - GROUND PLATES FOR NAUTICAL USE

PACKAGING - PACKAGING

STANDARD PLATE

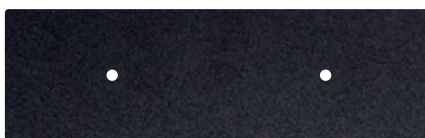

SEPARATORE PVC
PVC SEPARATOR

SEAGROUND®

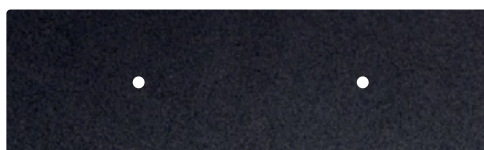

SEPARATORE PVC
PVC SEPARATOR



ISO 9001:2000
RINA
member of CISQ Federation



ISO 9001:2000
AFAQ-AFNOR
Certification



La SAS srl produce PIASTRE DI MASSA da oltre 30 anni, sia nella versione standard (con foro passante) che nella versione Seaground® brevettata (con foro filettato). Il materiale utilizzato per la produzione delle viti di fissaggio è rigorosamente identico a quello utilizzato per la costruzione delle piastre. Il modello rotondo (brevettato) consente l'installazione praticando un solo foro sullo scafo. VITI E DADI DI FISSAGGIO VENGONO FORNITI DORATI.

SAS srl has been producing GROUND PLATES for over 30 years, both in the standard version (with through hole) and in the patented Seaground® version (with threaded hole). The material used for the production of the fixing screws is strictly identical to that used for the construction of the plates. The round model (patented) allows installation by making a single hole in the hull. SCREWS AND FIXING NUTS ARE SUPPLIED GOLDEN.

STANDARD PLATE

| STANDARD 3 | DIMENSIONI SIZES | PESO WEIGHT | SUPERFICIE SURFACE | |
|------------|---------------------------|-----------------------|--|---|
| | Ø 128-H13 (Ø 5"-H1/2") | 0,60 Kg (1,30 lbs) | 1,50 m ² (17 ft ²) | 1 |

| STANDARD 0 | DIMENSIONI SIZES | PESO WEIGHT | SUPERFICIE SURFACE | |
|--|---------------------------|-----------------------|--|---|
| | 155x51x13 (6"x2"x1/2") | 0,45 Kg (1,00 lbs) | 1,00 m ² (11 ft ²) | 1 |
| Interasse fori: 68 mm. - <i>Hole spacing: 68 mm.</i> | | | | |

| STANDARD 1 | DIMENSIONI SIZES | PESO WEIGHT | SUPERFICIE SURFACE | |
|--|-----------------------------|-----------------------|--|---|
| | 206x65x13 (8"x2,5"x1/2") | 0,80 Kg (1,80 lbs) | 1,80 m ² (20 ft ²) | 1 |
| Interasse fori: 103 mm. - <i>Hole spacing: 103 mm.</i> | | | | |

| STANDARD 2 | DIMENSIONI SIZES | PESO WEIGHT | SUPERFICIE SURFACE | |
|--|----------------------------|-----------------------|--|---|
| | 300x80x13 (12"x3"x1/2") | 1,60 Kg (3,50 lbs) | 3,00 m ² (34 ft ²) | 1 |
| Interasse fori: 215 mm. - <i>Hole spacing: 215 mm.</i> | | | | |

| STANDARD 4 | DIMENSIONI SIZES | PESO WEIGHT | SUPERFICIE SURFACE | |
|---|-----------------------------|-----------------------|--|---|
| | 455x150x13 (18"x6"x1/2") | 4,20 Kg (9,30 lbs) | 8,00 m ² (90 ft ²) | 1 |
| Interasse fori: 255 mm. (orizzontale) - 75 mm. (verticale) <i>Hole spacing: 255 mm. (horizontal) - 75 mm. (vertical)</i> | | | | |

| QUANTITÀ QUANTITY | 1 | 2 ÷ 5 | 6 ÷ 25 | 26 ÷ 50 | > 50 |
|----------------------|---|-------|--------|---------|------|
| SCONTO DISCOUNT | - | 20% | 30% | 40% | 50% |

Interasse fori - *Hole spacing: 255 mm.*



ISO 9001:2000
RINA
member of CISQ Federation







ISO 9001:2000
AFAQ-AFNOR
Certification

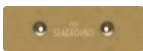

La SAS srl produce PIASTRE DI MASSA da oltre 30 anni, sia nella versione standard (con foro passante) che nella versione Seaground® brevettata (con foro filettato). Il materiale utilizzato per la produzione delle viti di fissaggio è rigorosamente identico a quello utilizzato per la costruzione delle piastre. Il modello rotondo (brevettato) consente l'installazione praticando un solo foro sullo scafo. VITI E DADI DI FISSAGGIO VENGONO FORNITI DORATI.

SAS srl has been producing GROUND PLATES for over 30 years, both in the standard version (with through hole) and in the patented Seaground® version (with threaded hole). The material used for the production of the fixing screws is strictly identical to that used for the construction of the plates. The round model (patented) allows installation by making a single hole in the hull. SCREWS AND FIXING NUTS ARE SUPPLIED GOLDEN.

SEAGROUND®

| SEAGROUND® | DIMENSIONI SIZES | PESO WEIGHT | SUPERFICIE SURFACE | | |
|---|-----------------------------|-----------------------|--|---------|------|
| SEAGROUND® 3  | Ø 128-H13 (Ø 5"-H1/2") | 0,60 Kg (1,30 lbs) | 1,50 m ² (17 ft ²) | 1 | |
| SEAGROUND® 0  | 155x51x13 (6"x2"x1/2") | 0,45 Kg (1,00 lbs) | 1,00 m ² (11 ft ²) | 1 | |
| Interasse fori: 68 mm. - <i>Hole spacing: 68 mm.</i> | | | | | |
| SEAGROUND® 1  | 206x65x13 (8"x2,5"x1/2") | 0,80 Kg (1,80 lbs) | 1,80 m ² (20 ft ²) | 1 | |
| Interasse fori: 103 mm. - <i>Hole spacing: 103 mm.</i> | | | | | |
| SEAGROUND® 2  | 300x80x13 (12"x3"x1/2") | 1,60 Kg (3,50 lbs) | 3,00 m ² (34 ft ²) | 1 | |
| Interasse fori: 215 mm. - <i>Hole spacing: 215 mm.</i> | | | | | |
| SEAGROUND® 4  | 455x150x13 (18"x6"x1/2") | 4,20 Kg (9,30 lbs) | 8,00 m ² (90 ft ²) | 1 | |
| Interasse fori: 255 mm. (orizzontale) - 75 mm. (verticale) <i>Hole spacing: 255 mm. (horizontal) - 75 mm. (vertical)</i> | | | | | |
| QUANTITÀ QUANTITY | 1 | 2 + 5 | 6 + 25 | 26 + 50 | > 50 |
| SCONTO DISCOUNT | - | 20% | 30% | 40% | 50% |



ISO 9001:2000
RINA
member of CISQ Federation









ISO 9001:2000
AFAQ-AFNOR
Certification



Il nuovo tipo Superplate® presenta una superficie maggiorata ed una maggior efficienza dovuta ai canali praticati nel corpo della piastra. Inoltre utilizza un innovativo sistema di fissaggio che non prevede i fori passanti.

The new Superplate® type has an increased surface and greater efficiency due to the channels made in the body of the plate. It also uses an innovative fixing system that does not use through holes.

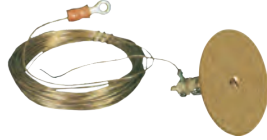
SUPERPLATE®

| | | |
|---|---|---|
| <p>SUPERPLATE® 0</p>  | <p>DIMENSIONI SIZES 155x51x13 (6"x2"x1/2")</p> <p>PESO WEIGHT 0,41 Kg (0,90 lbs)</p> <p>SUPERFICIE SURFACE 1,10 m² (12,20 ft²)</p> <p>Interasse fori: 68 mm. <i>Hole spacing: 68 mm.</i></p> | <p>LIGHT</p>  |
| <p>SUPERPLATE® 1</p>  | <p>DIMENSIONI SIZES 200x65x13 (8"x2,5"x1/2")</p> <p>PESO WEIGHT 0,72 Kg (1,62 lbs)</p> <p>SUPERFICIE SURFACE 2,00 m² (22,20 ft²)</p> <p>Interasse fori: 103 mm. <i>Hole spacing: 103 mm.</i></p> | <p>SEALIGHT</p>  |
| <p>SUPERPLATE® 2</p>  | <p>DIMENSIONI SIZES 300x80x13 (12"x3"x1/2")</p> <p>PESO WEIGHT 1,44 Kg (3,15 lbs)</p> <p>SUPERFICIE SURFACE 3,35 m² (37,80 ft²)</p> <p>Interasse fori: 215 mm. <i>Hole spacing: 215 mm.</i></p> | <p>SEATANK</p>  |
| <p>BANDELLA DI RAME SEASTRAP <i>COPPER STRIP SEASTRAP</i></p>  | <p>LARGHEZZA WIDTH 50 mm</p> <p>SPESSORE THICKNESS 0,5 mm</p> <p>LUNGHEZZA LENGTH 10 m (bobina) (coil)</p> <p>La bandella di rame SEASTRAP è adesiva. <i>The SEASTRAP copper strip is adhesive.</i></p> | <p>1</p> |
| <p>QUANTITÀ <i>QUANTITY</i></p> | <p>1</p> | <p>2 + 5</p> |
| <p>SCONTO <i>DISCOUNT</i></p> | <p>-</p> | <p>6 + 25</p> |
| | | <p>26 + 50</p> |
| | | <p>> 50</p> |
| | | <p>30%</p> |
| | | <p>40%</p> |
| | | <p>50%</p> |

ACCESSORI STANDARD IN DOTAZIONE - STANDARD ACCESSORIES SUPPLIED

| VITI DI FISSAGGIO FIXING SCREWS | Ø | LUNGHEZZA LENGTH |
|---|--------------------------|---------------------|
|  | 6 MA | 60 mm |
| | 8 MA | 80 mm |
| | A RICHIESTA / ON REQUEST | |
| | 6 MA | 95 mm |
| | 8 MA | 100 mm |

| DADI ESAGONALI HEX NUTS | Øi | CH | SPESSORE THICKNESS |
|--|------|----|-----------------------|
|  | 6 MA | 17 | 6 mm |
| | 8 MA | 17 | 6 mm |
| Bronzo - Bronze | | | |

| DISTANZIALI NYLON NYLON WASHERS | Øi | SPESSORE THICKNESS |
|---|------|-----------------------|
|  | 6 mm | 7,8 mm |
| | 8 mm | 7,8 mm |
| Nylon | | |

| SEPARATORE PVC TIPO 3 PVC SEPARATOR TYPE 3 | Øi | Ø | SPESSORE THICKNESS |
|--|------|--------|-----------------------|
|  | 6 mm | 128 mm | 2 mm |
| PVC | | | |

| SEPARATORE PVC TIPO 0 PVC SEPARATOR TYPE 0 | DIMENSIONI SIZES | INTERASSE FORI HOLE SPACING | DIAMETRO FORO HOLE DIAMETER | SPESSORE THICKNESS |
|--|---------------------|--------------------------------|--------------------------------|-----------------------|
|  | 155x51 mm | 68 mm. | 6 mm | 2 mm |
| PVC | | | | |

| SEPARATORE PVC TIPO 1 PVC SEPARATOR TYPE 1 | DIMENSIONI SIZES | INTERASSE FORI HOLE SPACING | DIAMETRO FORO HOLE DIAMETER | SPESSORE THICKNESS |
|---|---------------------|--------------------------------|--------------------------------|-----------------------|
|  | 200x65 mm | 103 mm. | 6 mm | 2 mm |
| PVC | | | | |

| SEPARATORE PVC TIPO 2 PVC SEPARATOR TYPE 2 | DIMENSIONI SIZES | INTERASSE FORI HOLE SPACING | DIAMETRO FORO HOLE DIAMETER | SPESSORE THICKNESS |
|---|---------------------|--------------------------------|--------------------------------|-----------------------|
|  | 300x80 mm | 215 mm. | 8 mm | 2 mm |
| PVC | | | | |

| SEPARATORE PVC TIPO 4 PVC SEPARATOR TYPE 4 | DIMENSIONI SIZES | INTERASSE FORI HOLE SPACING | DIAMETRO FORO HOLE DIAMETER | SPESSORE THICKNESS |
|---|---------------------|--------------------------------|--------------------------------|-----------------------|
|  | 455x150 mm | 255/75 mm | 8 mm | 2 mm |
| PVC | | | | |



ISO 9001:2000
RINA
member of CISQ Federation



ISO 9001:2000
AFAQ-AFNOR
Certification

Le Pastre di massa tipo A e tipo B sono dotate di presa a mare (tipo A) e scarico a mare (tipo B), entrambi in bronzo.

Type A and Type B Ground Plates are equipped with water intakes (A) and thru-hulls (B), both made of bronze.



TIPO A
A TYPE



PRESA A MARE
WATER INTAKES



TIPO B
B TYPE

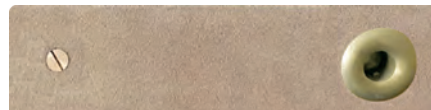

SCARICO A MARE
THRU-HULLS

PRESA A MARE - WATER INTAKES

SCARICO A MARE - THRU-HULLS

| WIN-GP 1/2" | DIMENSIONI SIZES | PESO WEIGHT | SUPERFICIE SURFACE | 🛒 |
|--|------------------------------|--|---|---|
| | 206x65x13 mm 8"x2,5"x1/2" | 1,034 Kg 2,324 lbs | 1,80 m ² 20 ft ² | 1 |
|  | | Interasse fori: 68 mm. Hole spacing: 68 mm. | | |
| Piastre di massa con presa a mare Ground plates with water intakes | | | | |

| THU-GP 1/2" | DIMENSIONI SIZES | PESO WEIGHT | SUPERFICIE SURFACE | 🛒 |
|---|------------------------------|--|---|---|
| | 206x65x13 mm 8"x2,5"x1/2" | 0,944 Kg 2,120 lbs | 1,80 m ² 20 ft ² | 1 |
|  | | Interasse fori: 68 mm. Hole spacing: 68 mm. | | |
| Piastre di massa con scarico a mare Ground plates with thru-hulls | | | | |

| WIN-GP 3/4" | DIMENSIONI SIZES | PESO WEIGHT | SUPERFICIE SURFACE | 🛒 |
|--|------------------------------|--|---|---|
| | 206x65x13 mm 8"x2,5"x1/2" | 1,117 Kg 2,510 lbs | 1,80 m ² 20 ft ² | 1 |
|  | | Interasse fori: 68 mm. Hole spacing: 68 mm. | | |
| Piastre di massa con presa a mare Ground plates with water intakes | | | | |

| THU-GP 3/4" | DIMENSIONI SIZES | PESO WEIGHT | SUPERFICIE SURFACE | 🛒 |
|---|------------------------------|--|---|---|
| | 206x65x13 mm 8"x2,5"x1/2" | 1,007 Kg 2,263 lbs | 1,80 m ² 20 ft ² | 1 |
|  | | Interasse fori: 68 mm. Hole spacing: 68 mm. | | |
| Piastre di massa con scarico a mare Ground plates with thru-hulls | | | | |

| WIN-GP 1" | DIMENSIONI SIZES | PESO WEIGHT | SUPERFICIE SURFACE | 🛒 |
|--|-----------------------------|--|---|---|
| | 300x80x13 mm 12"x3"x1/2" | 2,167 Kg 4,870 lbs | 3,00 m ² 34 ft ² | 1 |
|  | | Interasse fori: 215 mm. Hole spacing: 215 mm. | | |
| Piastre di massa con presa a mare Ground plates with water intakes | | | | |

| THU-GP 1" | DIMENSIONI SIZES | PESO WEIGHT | SUPERFICIE SURFACE | 🛒 |
|---|-----------------------------|--|---|---|
| | 300x80x13 mm 12"x3"x1/2" | 1,892 Kg 4,250 lbs | 3,00 m ² 34 ft ² | 1 |
|  | | Interasse fori: 215 mm. Hole spacing: 215 mm. | | |
| Piastre di massa con scarico a mare Ground plates with thru-hulls | | | | |

| WIN-GP 1*1/2" | DIMENSIONI SIZES | PESO WEIGHT | SUPERFICIE SURFACE | 🛒 |
|--|-----------------------------|--|---|---|
| | 300x80x13 mm 12"x3"x1/2" | 2,636 Kg 5,925 lbs | 3,00 m ² 34 ft ² | 1 |
|  | | Interasse fori: 215 mm. Hole spacing: 215 mm. | | |
| Piastre di massa con presa a mare Ground plates with water intakes | | | | |

| THU-GP 1*1/2" | DIMENSIONI SIZES | PESO WEIGHT | SUPERFICIE SURFACE | 🛒 |
|---|-----------------------------|--|---|---|
| | 300x80x13 mm 12"x3"x1/2" | 2,214 Kg 4,975 lbs | 3,00 m ² 34 ft ² | 1 |
|  | | Interasse fori: 215 mm. Hole spacing: 215 mm. | | |
| Piastre di massa con scarico a mare Ground plates with thru-hulls | | | | |

| | | | | | |
|----------------------|---|-------|--------|---------|------|
| QUANTITÀ QUANTITY | 1 | 2 ÷ 5 | 6 ÷ 25 | 26 ÷ 50 | > 50 |
| SCONTO DISCOUNT | - | 20% | 30% | 40% | 50% |

WIN-GP - PRESA A MARE - *WATER INTAKES*



Filettature / *Thread*
G ISO 228/1 (BS 2779)

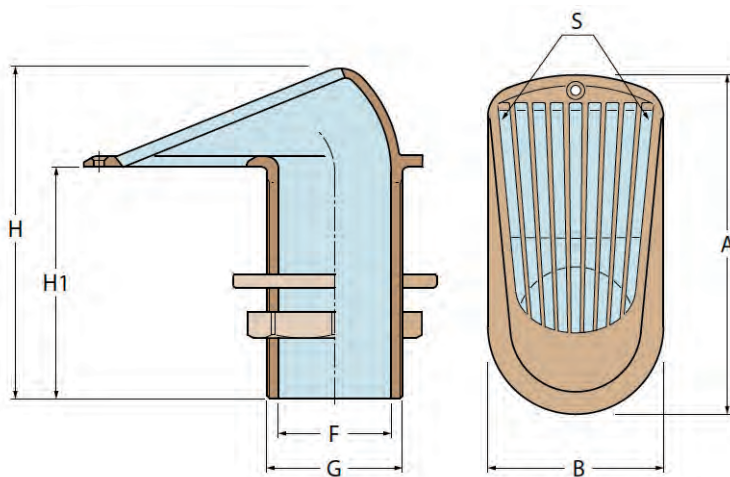

| | | | | | |
|---------------------------|------|------|-----|--------|------|
| PESO / <i>WEIGHT</i> (GR) | 260 | 360 | 635 | 1177 | 1706 |
| S (cm ²) | 6,2 | 7 | 15 | 25,5 | 37 |
| H | 95 | 103 | 111 | 129 | 142 |
| H1 | 75 | 80 | 85 | 100 | 110 |
| F | 11,5 | 15 | 25 | 38,5 | 49,5 |
| A | 74 | 81 | 104 | 130 | 154 |
| B | 37 | 40 | 55 | 71 | 84 |
| G | 1/2" | 3/4" | 1" | 1" 1/2 | 2" |

THU-GP - SCARICO A MARE - *THRU-HULLS*



Filettature / *Thread*
G ISO 228/1 (BS 2779)

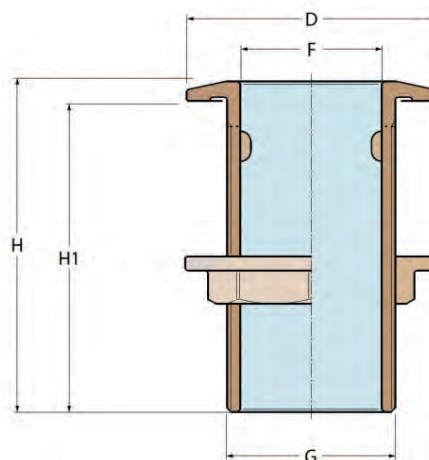

| | | | | | |
|---------------------------|------|------|-----|--------|------|
| PESO / <i>WEIGHT</i> (GR) | 170 | 250 | 360 | 755 | 1040 |
| H | 70 | 75 | 85 | 96 | 107 |
| D | 40 | 47 | 57 | 75 | 88 |
| H1 | 65 | 70 | 80 | 90 | 100 |
| F | 13 | 19 | 25 | 38 | 50 |
| G | 1/2" | 3/4" | 1" | 1" 1/2 | 2" |

PER MAGGIORI INFORMAZIONI E PREZZI CONTATTARE IL NOSTRO UFFICIO COMMERCIALE
FOR MORE INFORMATION AND PRICES PLEASE CONTACT OUR SALES OFFICE



EXTRA

ANELLI & BRACCIALI - RINGS & BRACELETS



Info & Contatti: Numbering - Francesca Valpiani - SAS Sinterizzati s.r.l. - Tel +39 051 829 853 - store@numbering.me
Info & Contacts: Numbering - Francesca Valpiani - SAS Sinterizzati s.r.l. - Tel +39 051 829 853 - store@numbering.me

MEDAGLIE - MEDALS



Info & Contatti: Numbering - Francesca Valpiani - SAS Sinterizzati s.r.l. - Tel +39 051 829 853 - store@numbering.me
Info & Contacts: Numbering - Francesca Valpiani - SAS Sinterizzati s.r.l. - Tel +39 051 829 853 - store@numbering.me

GADGETS - GADGETS



PORTACHIAVI
KEY RINGS

LEVA CAPSULE
CAPSULE LEVER



SCHIACCIA NOCI
NUTCRACKER

DIFFUSORI DI PROFUMI - DIFFUSERS OF PERFUMES



Info & Contatti: Numbering - Francesca Valpiani - SAS Sinterizzati s.r.l. - Tel +39 051 829 853 - store@numbering.me
 Info & Contacts: Numbering - Francesca Valpiani - SAS Sinterizzati s.r.l. - Tel +39 051 829 853 - store@numbering.me

SISTEMA DI UMIDIFICAZIONE E SANIFICAZIONE



CARATTERISTICHE

Alto grado di umidificazione: consumo acqua 10,4 L ora, 100% di atomizzazione, e un solo apparecchio può fare aumentare il valore dell'umidità fino al 50% in 2 minuti.

Riduzione della temperatura all'interno: con una vaporizzazione del 100%, si può ridurre molto rapidamente la temperatura all'interno.

Alto grado di eliminazione della polvere: quando si spruzza, si produce una grande quantità di ioni di ossigeno che neutralizzano le cariche positive in modo da assorbire e raccogliere le particelle di polvere per poi eliminarle.

Riduzione dell'elettrostaticità: quando si spruzza, si produce una grande quantità di ioni di ossigeno che neutralizzano le cariche positive in modo da eliminare l'elettricità statica. Con l'aumento dell'umidità, si riduce molto l'elettricità statica.

Disinfezione e prevenzione medica: può essere dotato di miscelatore per ottenere la funzione di sanificazione.

| Cod | Capacità aria (l/min) | | | Capacità liquido (l/min) | | | Sauter Mean Dia (µm) Spray | | |
|-----------|-----------------------|-------|-------|--------------------------|-------|-------|----------------------------|-------|-------|
| | 2,5 Bar | 3 Bar | 4 Bar | 2,5 Bar | 3 Bar | 4 Bar | 2,5 Bar | 3 Bar | 4 Bar |
| NBP1.0N | 30,0 | 35,0 | 45,0 | 0,9 | 1,0 | 1,1 | 8,5 | 8,5 | 8,5 |
| NBP2,5.0N | 30,0 | 35,0 | 45,0 | 2,3 | 2,5 | 2,6 | 8,5 | 8,5 | 8,5 |
| NBP3.0N | 30,0 | 35,0 | 45,0 | 2,8 | 3,0 | 3,2 | 8,5 | 8,5 | 8,5 |
| NBP4,5.0N | 35,0 | 40,0 | 50,0 | 4,1 | 4,5 | 4,8 | 8,5 | 8,5 | 8,5 |

| Materiale | Corpo | Polipropilene |
|-------------|-------------|---------------|
| | Ugello | 304 SS |
| | Imballaggio | Fluoro-gomma |
| Connessione | Lato aria | 1/4" |
| | Lato acqua | 1/8" |
| Peso | | 250 |

FUNZIONI PER UN FACILE SETUP E SEMPLICE MANUTENZIONE

Per montare e smontare gli ugelli girare il coperchio di 45°. Funzioni per una facile manutenzione sono previste in tutti gli apparecchi o nel Mini Fogger III.

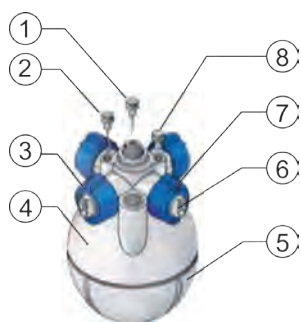

- 1 Ago per pulire nel tappo il foro di uscita del liquido
- 2 Perno di aggancio per rimuovere il filtro
- 3 Facile rimozione dell'involucro dell'ugello
- 4 Girare manualmente il coperchio per toglierlo
- 5 Polipropilene resistente agli agenti chimici: viene usato per il materiale del corpo dell'apparecchio
- 6 Per montare e rimuovere l'ugello è sufficiente girarlo manualmente. Il cappuccio si allinea automaticamente
- 7 L'ugello è composto da 2 materiali: **Acciaio inossidabile** e **TEFLON**
- 8 Pin antirotazione per evitare la rotazione (in caso di montaggio a parete)

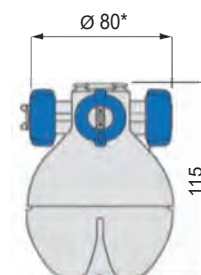

* Non compresa la parte dell'ugello
unità di misura = mm



Direzione regolabile dello spruzzo, da una via a quattro vie.

Una via - Manometro: per regolare la pressione

L'Ugello singolo con un getto che raggiunge una distanza di 5-6 m quando la pressione è 3 Bar, produce l'effetto umidificazione e raffreddamento in uno spazio di 100 m quadrati.

Due vie - Ugello a due vie

Spruzzando una miscela di aria e acqua si evitano i problemi di occlusione.

Tre vie - Erogazione di particelle d'acqua per una regolare umidificazione dello spazio.

La leggera umidità evapora velocemente, nessun bagnato sul pavimento (in terra se è all'aperto).

Quattro vie - Configurazione con sensore di temperatura ed umidità

Controllo della temperatura e dell'umidità: la precisione del ±1 si traduce in valori stabili della temperatura e dell'umidità.

- 1 Linea aria - 2 Liquido igienizzante

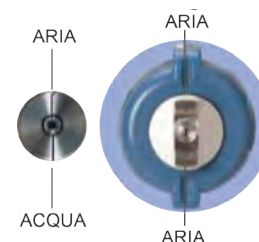

Doppio sistema di atomizzazione per produrre goccioline di piccola dimensione ed evitare occlusione.

Nel doppio sistema di atomizzazione viene erogata una miscela atomizzata di aria ed acqua dal foro centrale che poi viene nuovamente miscelata con l'aria dai fori laterali.

DRY FOG HUMIDIFICATION AND SANIFICATION SYSTEM



FEATURES

High efficiency humidification: water consumption 10,4 L per hour, 100% atomization, and one single unit can make the umidity up to 50% within 2 minutes.

Cooling the indoor temperature: 100% evaporate, can reduce the indoor temperature very quickly.

High-efficiency dust suppression: during spray, it can produce a large number of negative oxygen ions wich will neutralize positive charges so as to absorb and gather the dust particles and then drop down.

De-electrostatic: during spraying, it can produce a large number of negative oxygen ions wich neutralize positive charges so as to eliminate static electriciry. When the increase of humidity, static electriciry will be largely reduced.

Disinfection and medication prevention: can be equipped with disinfect mixer to achieve the disinfection function.

| CODE | Air Capacity(l/min) | | | Liquid Capacity (l/min) | | | Sauter Mean Dia (µm) Spray | | |
|-----------|---------------------|-------|-------|-------------------------|-------|-------|----------------------------|-------|-------|
| | 2,5 Bar | 3 Bar | 4 Bar | 2,5 Bar | 3 Bar | 4 Bar | 2,5 Bar | 3 Bar | 4 Bar |
| NBP1.0N | 30,0 | 35,0 | 45,0 | 0,9 | 1,0 | 1,1 | 8,5 | 8,5 | 8,5 |
| NBP2,5.0N | 30,0 | 35,0 | 45,0 | 2,3 | 2,5 | 2,6 | 8,5 | 8,5 | 8,5 |
| NBP3.0N | 30,0 | 35,0 | 45,0 | 2,8 | 3,0 | 3,2 | 8,5 | 8,5 | 8,5 |
| NBP4,5.0N | 35,0 | 40,0 | 50,0 | 4,1 | 4,5 | 4,8 | 8,5 | 8,5 | 8,5 |

| | | |
|------------|------------|---------------|
| Material | Body | Polypropilene |
| | Nozzle | 304 SS |
| | Packing | Fluoro-rubber |
| Connection | Air Side | 1/4" |
| | Water Side | 1/8" |
| Weight | 250 | |

BUILT IN FUNCTIONS FOR EASY SETUP AND EASY MANTEINANCE

For installation or removal of the nozzles, only turn the nozzle cap 45°. Easy manteinance functions have been built in everywhere or Mini Fogger III.

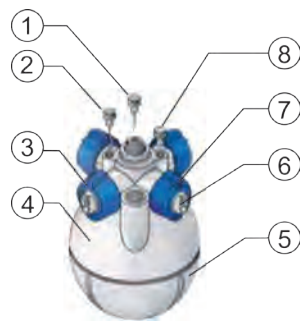

- 1 Cleaninn Pin for Fluid Cap Orifice
- 2 Hook Pin for removal of strainer
- 3 Easily Removal Nozzle Packing
- 4 Cover can be removed by a simple hand turn
- 5 Chemical resistant Polypropylene is used for the body material
- 6 Nozzle can be installed or removed by a simple had turn. Cap has self alignment funtion
- 7 Nozzle materials in 2 types: **Stainless Steel** and **TEFLON**
- 8 Antirotation Pin (for installation on a wall)

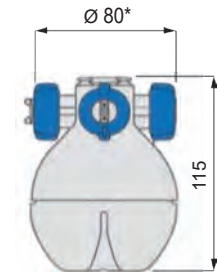

* Not including the nozzle part unit = mm



Spray direction is adjustable, from one-way to four ways.

One way: Pressure gauge: adjust the pressure
Single nozzle with jet out 5-6 m long distance mist when the pressure is 3 Bar, can manage the cooling and humidification effection in 100 sq. m space.

Two ways: Two-ways nozzle design
Water ad air mixed tojet out, solve the glogging problem.

Three ways: Spray water particles evenly humidifng the space
Slight moisture quickly evaporates, avoid wet ground conditions.

Four ways: Configure with Temperature and Humidity sensor
Temperature and humidity control, error control at ±1, mantein stable temperature and humidity.

1 Air Line - 2 Sanitizing Lquid Line

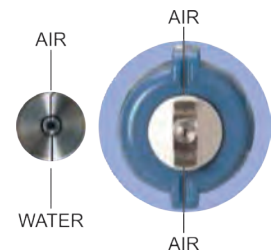

Double Atomizing System
to produce fine droplet size and to prevent glogging.

In the double atomizing system, fine mists mixture of air and water, are sprayed from the center orifice and then re-mixed with air from the side orifices.



DISPOSITIVO CONTRO LA DIFFUSIONE DEL COVID 19



Costo contenuto
Possibilità di sconti su acquisto di diversi dispositivi.



Garanzia 2 anni
Testato per durare il più a lungo possibile.



Nessun tracciamento
Il dispositivo non traccia né i contatti con gli altri dispositivi né la posizione, rispettando la privacy di chi lo indossa.



100% Made in Italy
Il dispositivo è stato progettato e costruito da un team completamente italiano.



Dispositivo brevettato
Brevetto certificato per modello di utilità.



Dispositivo stand-alone
Non richiede alcuna infrastruttura per funzionare.

Sicurezza dei pedoni

Può essere utilizzato per la sicurezza in ambienti dove circolano carrelli o macchinari a rischio investimento.

Funzionalità inversa

Il dispositivo può essere programmato per suonare quando due dispositivi vengono allontanati

Delimitazioni di aree

Il dispositivo può essere regolato per impedire l'accesso a determinate aree lavorative.

Limitare il numero di persone

Il dispositivo può essere impiegato come conta persone agli eventi regolamentandone l'accesso.

Come funziona

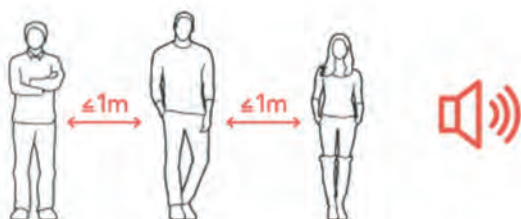

Se due o più dispositivi si trovano ad una distanza minore o uguale a quella di sicurezza, il dispositivo emette un segnale sonoro e una vibrazione, avvisando chi li indossa del pericolo di contagio.



Quando la distanza di sicurezza viene nuovamente raggiunta, il suono e la vibrazione cessano.



DEVICE AGAINST THE SPREAD OF COVID-19

| | | | | |
|----------------------|--|--|--|----------------------|
| Stand alone device | | | | Small and light |
| Easy to use | | | | High precision |
| Protect your privacy | | | | Very simple recharge |
| High autonomy | | | | Very low cost |
| Credit card size | | | | CE device |

Pedestrian safety

It can be used for safety in environments where trolleys or machinery at risk of investment circulate.

Reverse functionality

The device can be programmed to sound when two devices are pushed apart.

Delimitation of areas

The device can be adjusted to prevent access to certain work areas.

Limit the number of people

The device can be used as a people counter at events by regulating access.

HOW IT WORKS

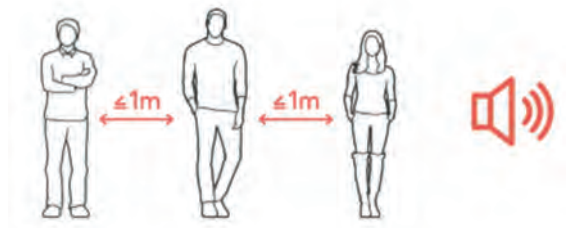

If two or more devices are located at a distance less than or equal to the safe distance, the device emits an audible signal and a vibration, warning the wearer of the danger of contagion.



When the safety distance is reached again, the sound and vibration cease.

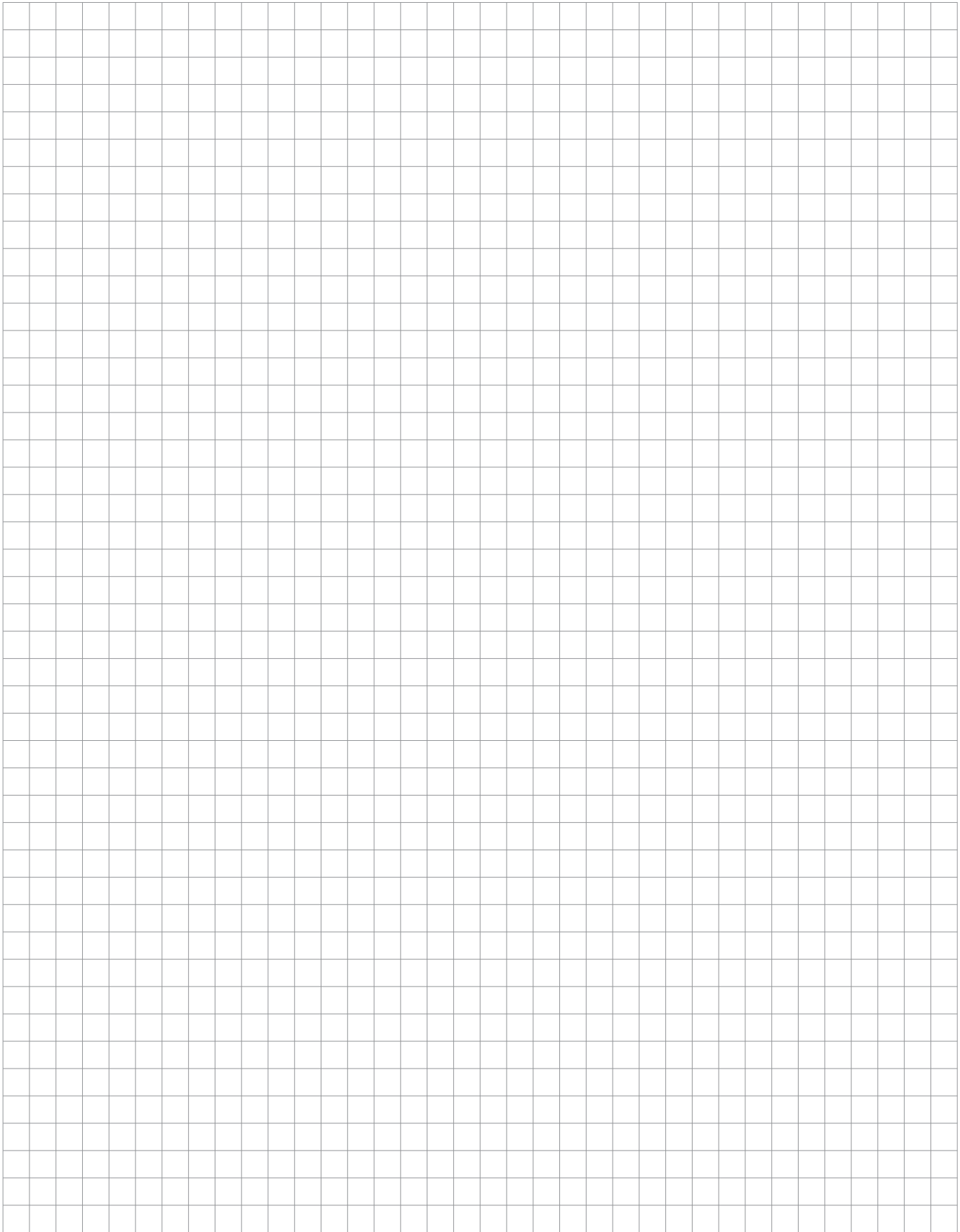



RIVENDITORE DI ZONA - SAS LOCAL DEALER



Produzione Sinterizzati - Sintered Production

Via Matteotti, 1 - 40010 Sala Bolognese (BO)

Tel. +39 051 829 312 - e-mail: sasbologna@sassinterizzati.com

Produzione Pneumatica - Pneumatic Production

Via Matteotti, 1 - 40010 Sala Bolognese (BO)

Tel. +39 0543 702 957 - e-mail: sasforlì@sassinterizzati.com

E.U.R.L. S.A.S. France

2 Impasse Prè Serpillon zone industrielle - 21210 Saulieu

Tel: +33 03 80 64 31 31 - e-mail: info@sasfrance-sintering.com

www.sassinterizzati.com